

The state of sCO₂ Research in South Africa



Presented by Colin Francois du Sart (Colin.duSart@uct.ac.za), University of Cape Town
in collaboration with Stellenbosch University

The 9th International Supercritical CO₂ Energy Technologies Symposium | 02 – 05 March 2026 | Pittsburgh, PA



- Established 2017
- ThermoFluid systems modelling to evaluate technologies, improve efficiency and control, and to enable condition monitoring.
- 100+ articles published in journals and conference proceedings
- 50+ Masters and PhD students graduated
- <https://ebe.uct.ac.za/atprom>



- Established 2010
- Solar thermal modelling and experimental research for policy recommendation and industrial, mineral processing and medium-scale utility applications.
- 300+ articles published in journals and conference proceedings
- 150+ Masters and PhD students graduated
- <https://sterg.sun.ac.za/>

About



Dr. Colin du Sart, Pr Eng



Prof. Pieter Rousseau, Pr Eng



Prof. Ryno Laubscher, Pr Eng



Dr. Rashid Haffejee



Prof. Craig McGregor, Pr Eng



Prof. Johan van der Spuy, Pr Eng



Prof. Johannes Pretorius, Pr Eng



Mr. Carl Tshamala



FLUENT



About

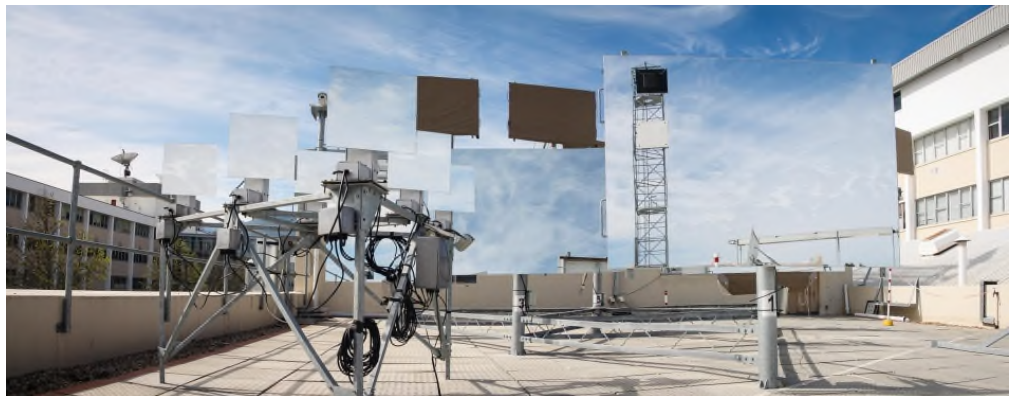

About

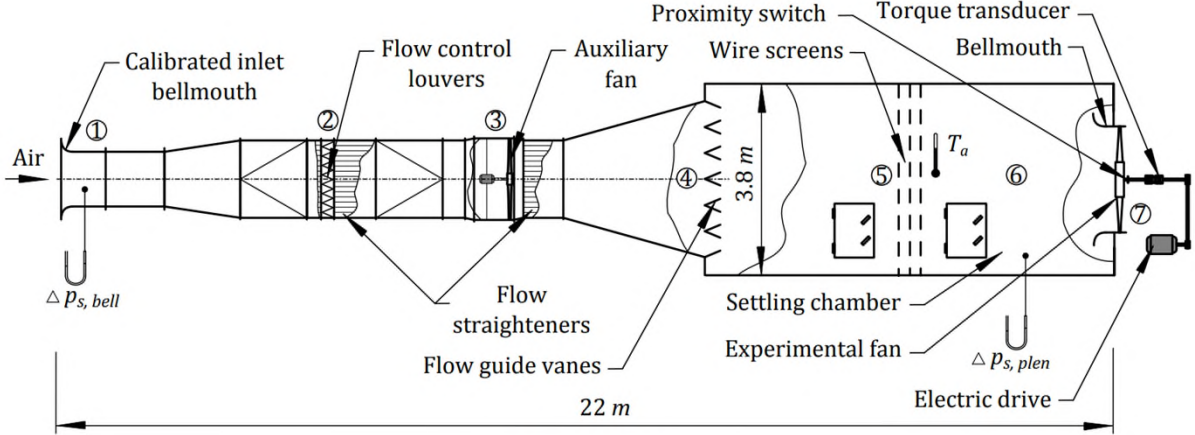

SIDE ELEVATION

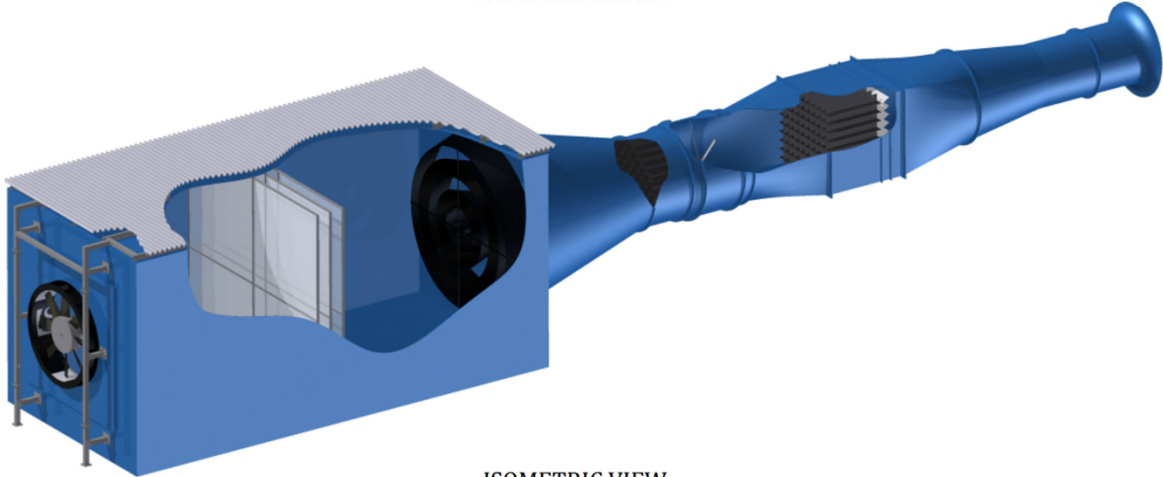

ISOMETRIC VIEW

Dynamic sCO₂ CSP-TES plant

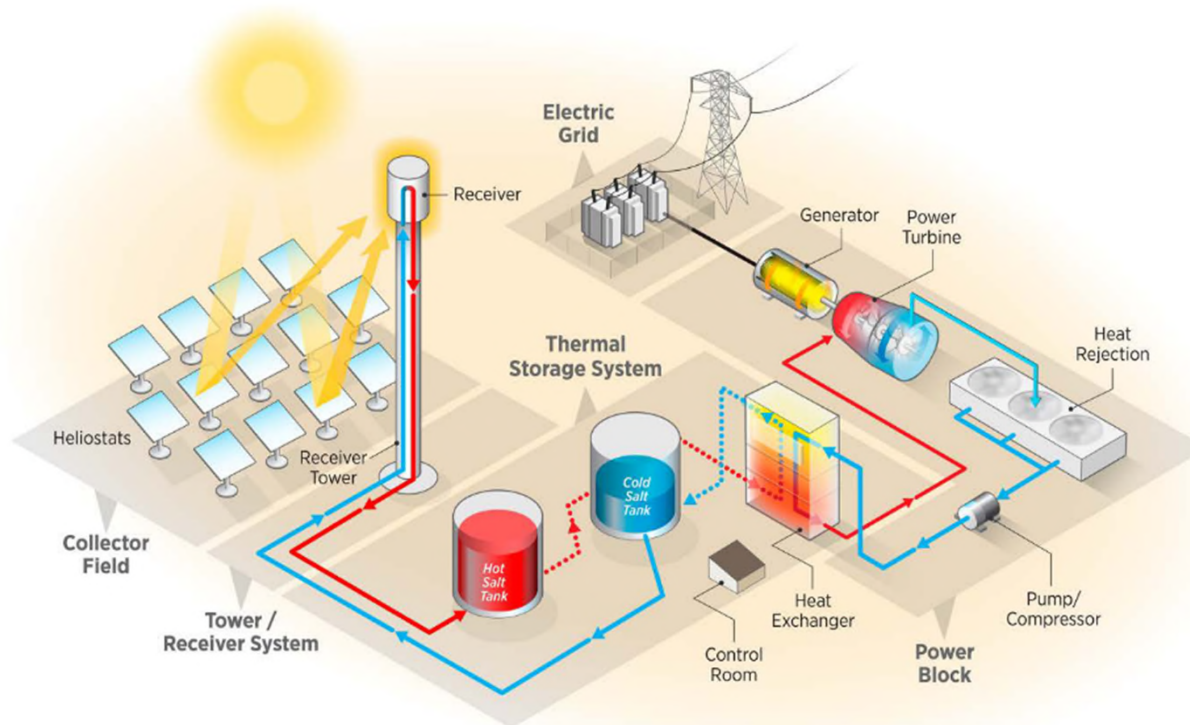

Schematic of a sCO₂-CSP plant with TES, from Mehos et al. (2017). Available: www.nrel.gov/docs/fy17osti/67464.pdf

Dynamic sCO2 CSP-TES plant

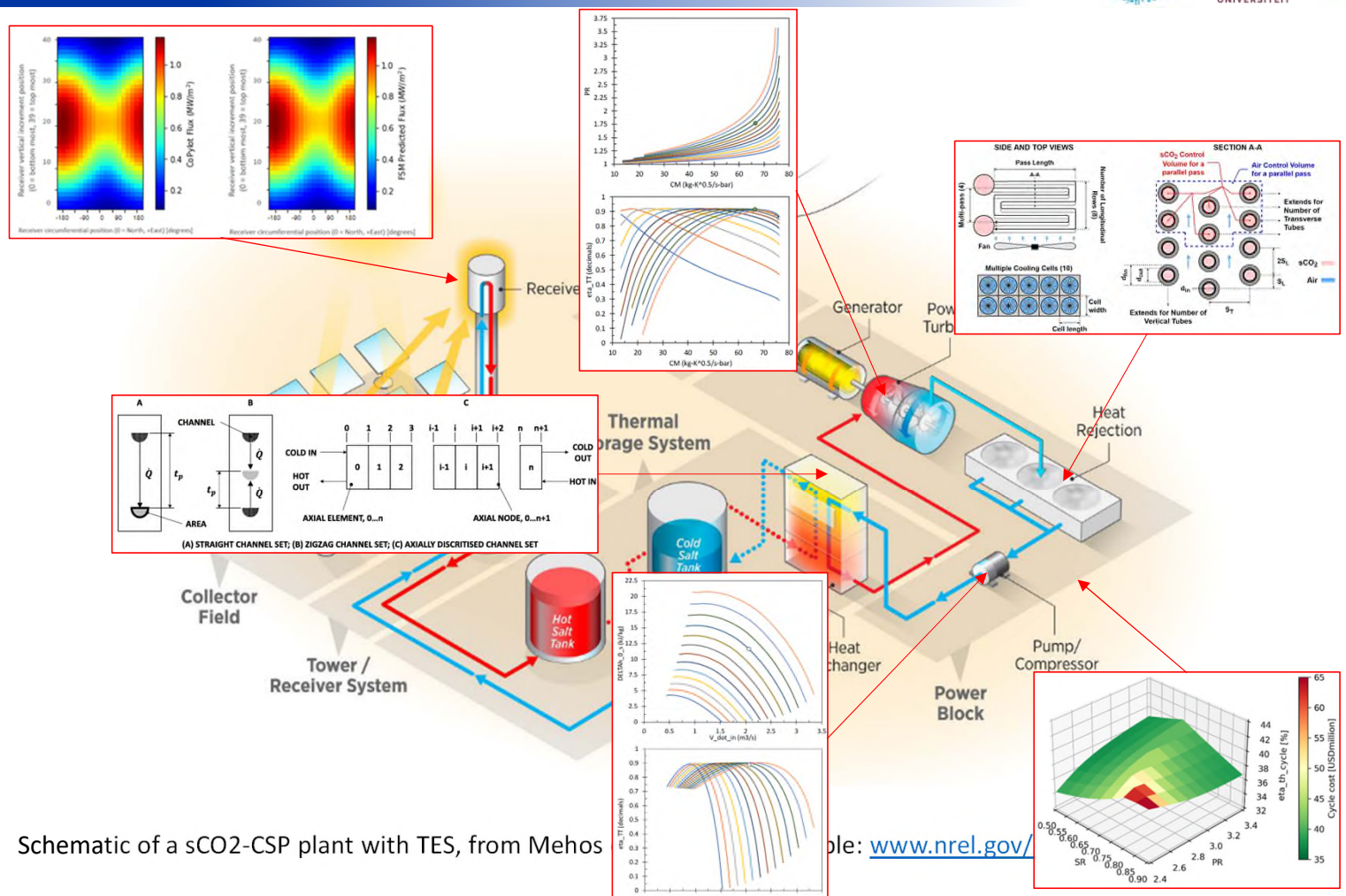

Schematic of a sCO₂-CSP plant with TES, from Mehos

Source: www.nrel.gov/

Dynamic sCO₂ CSP-TES plant

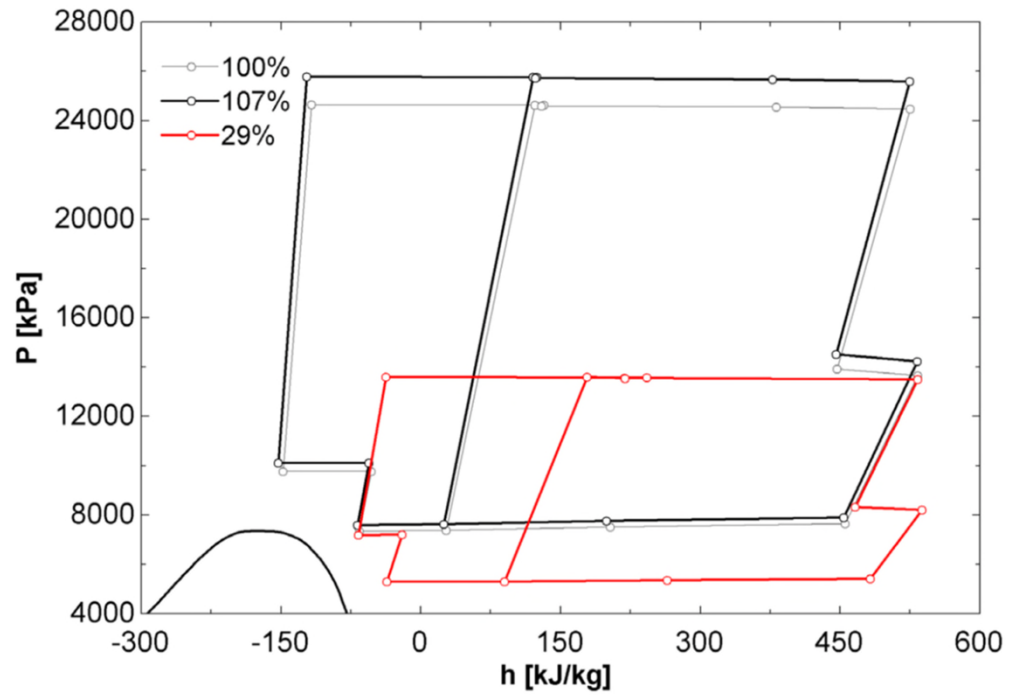
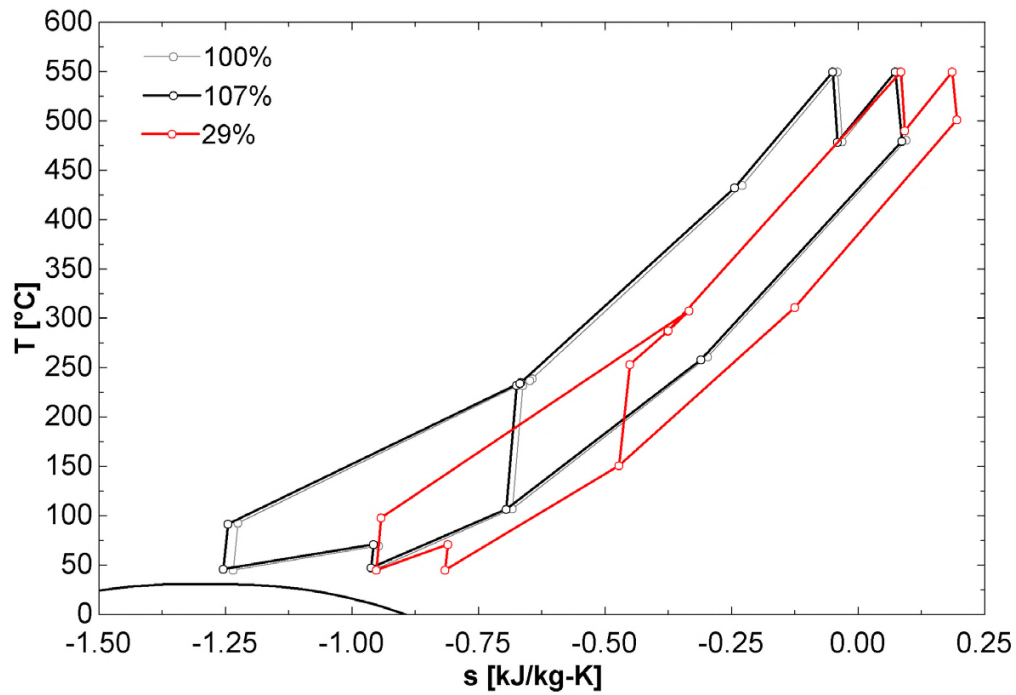

Dynamic sCO₂ CSP-TES plant

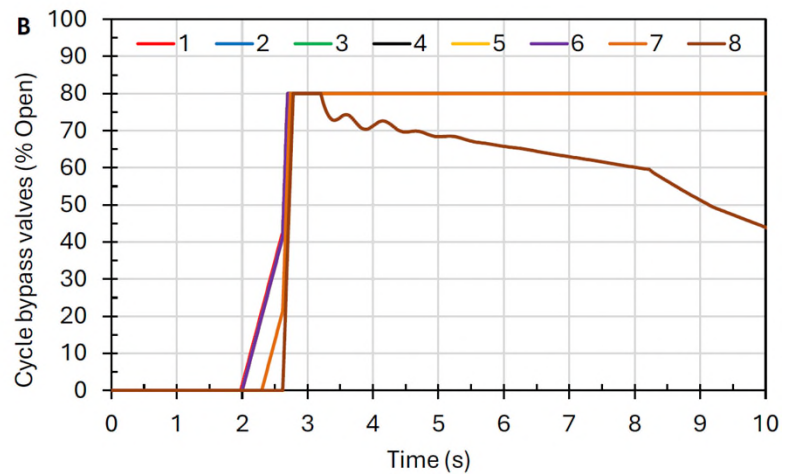
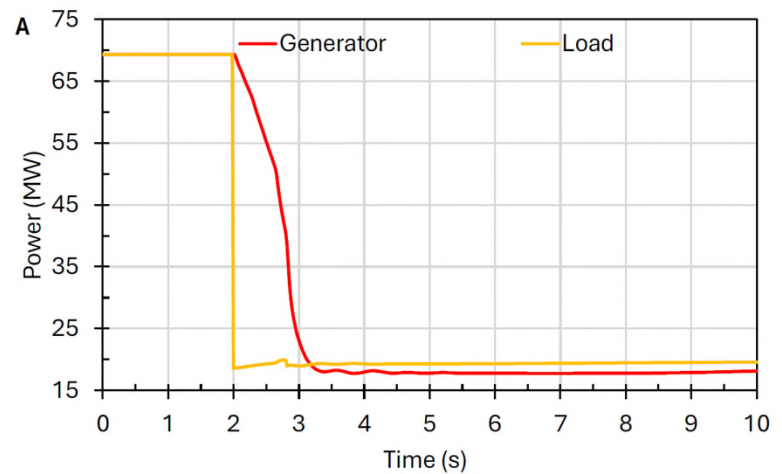
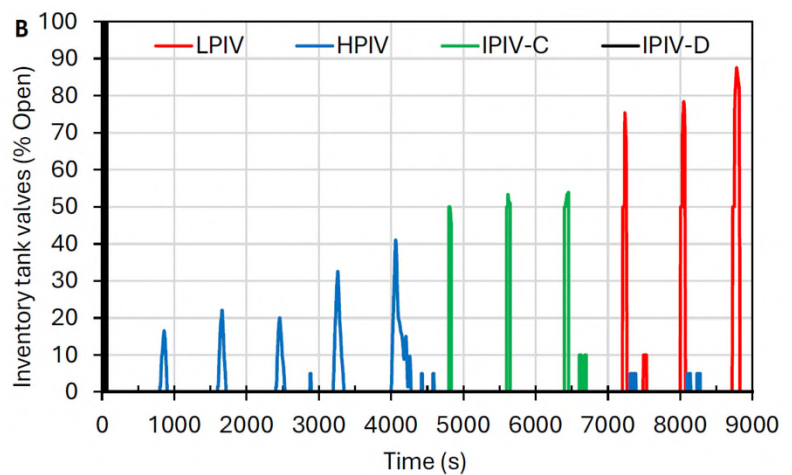
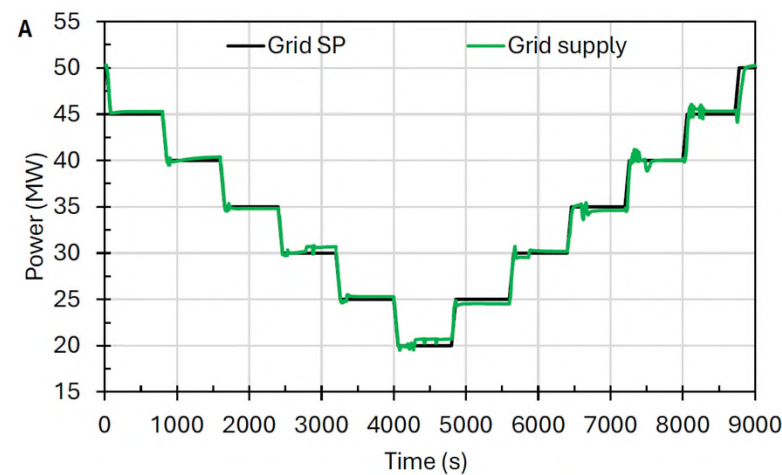

Combined sCO2 biomass-steam plant

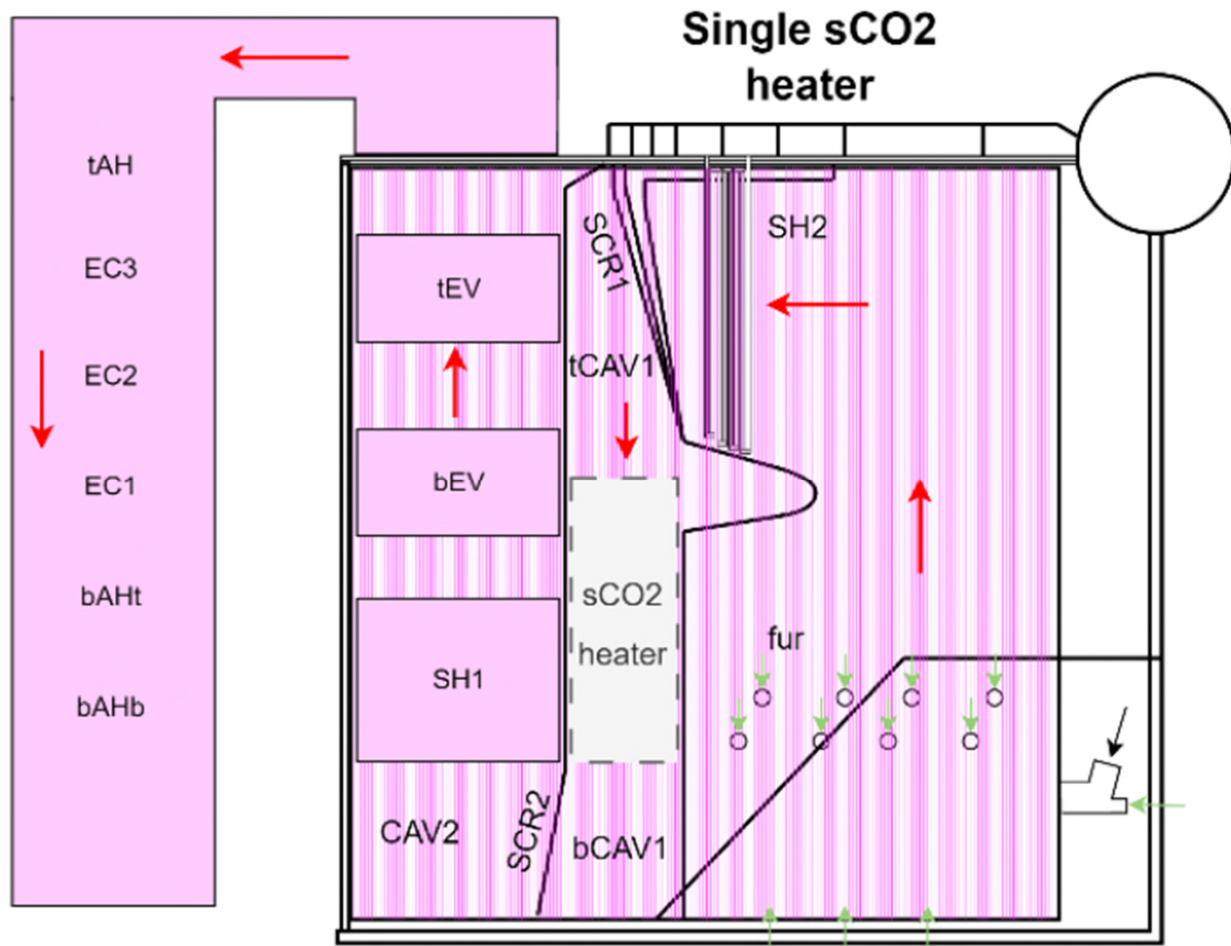

Combined sCO₂ biomass-steam plant

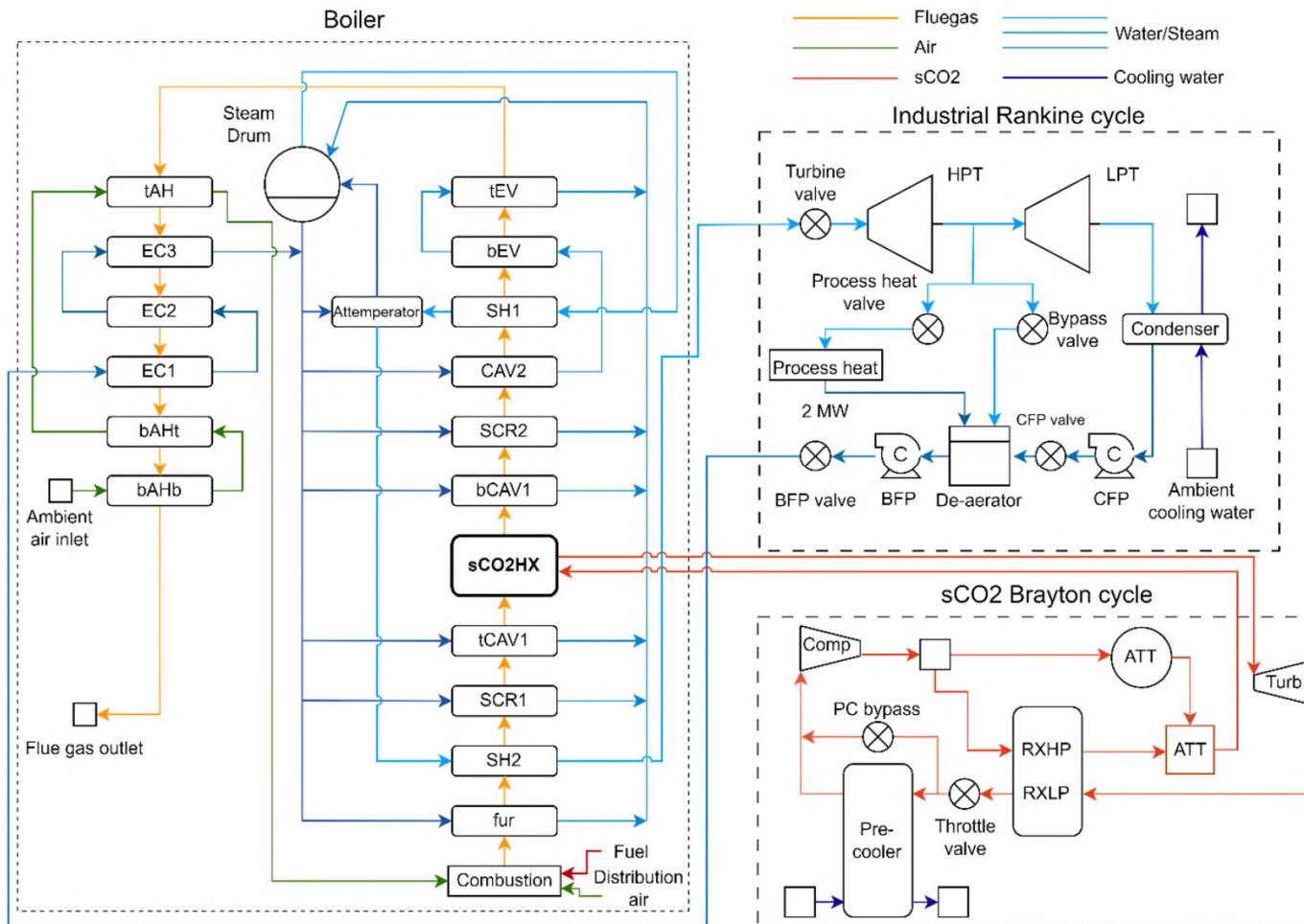

Combined sCO₂ biomass-steam plant

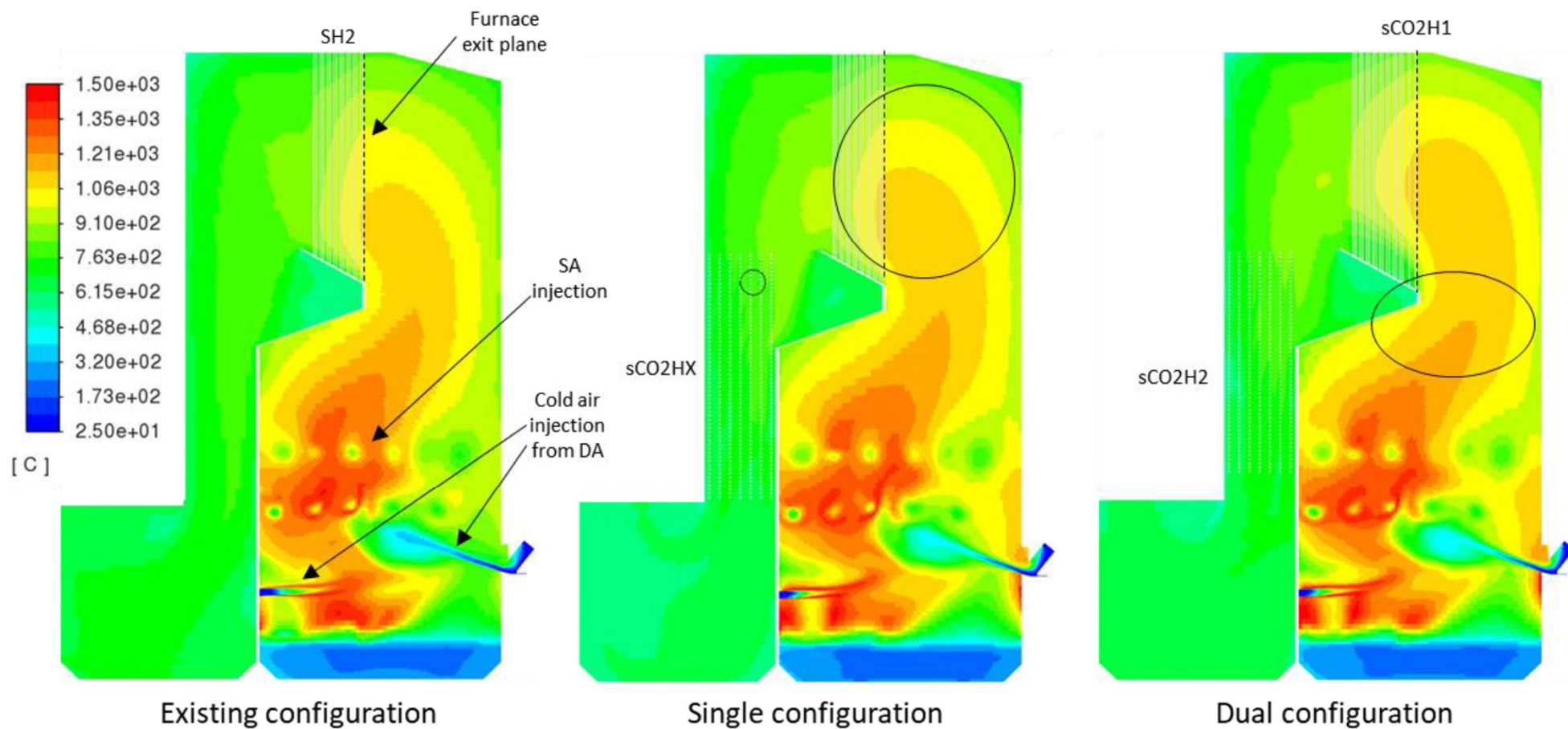

sCO₂ ACHE System

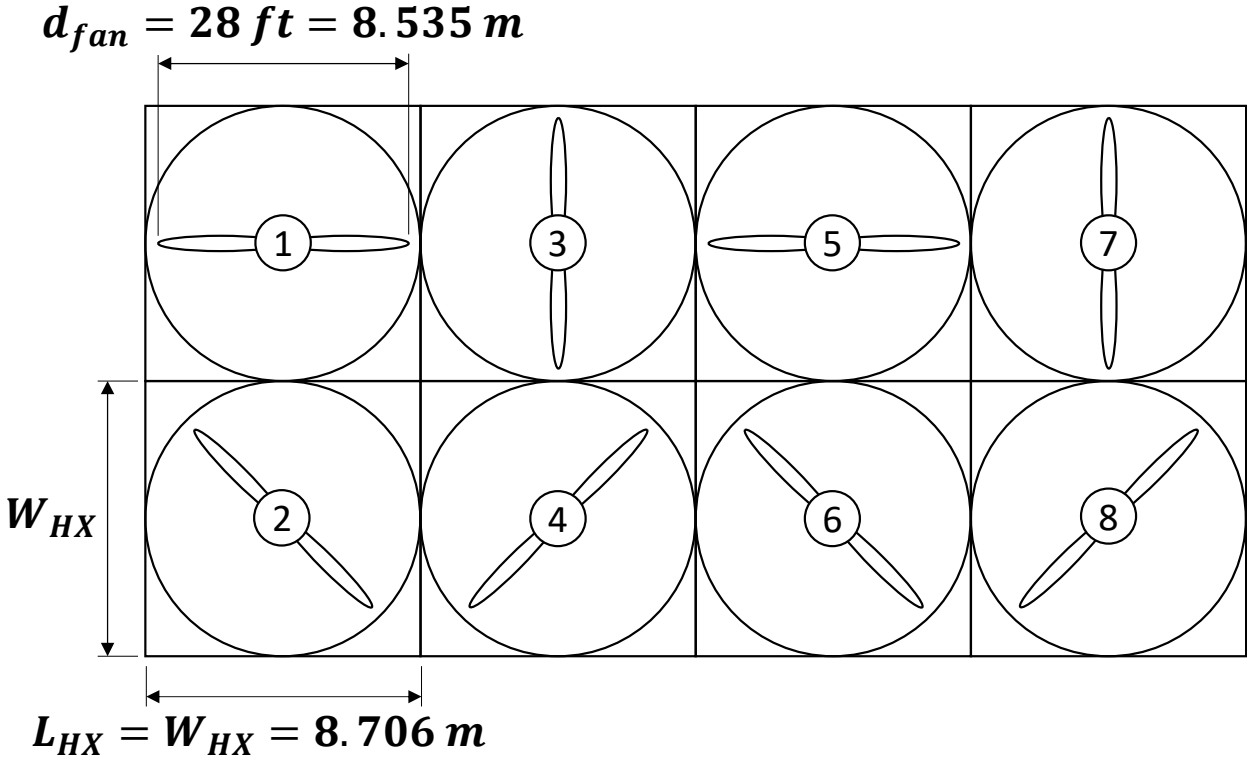

sCO₂ ACHE System

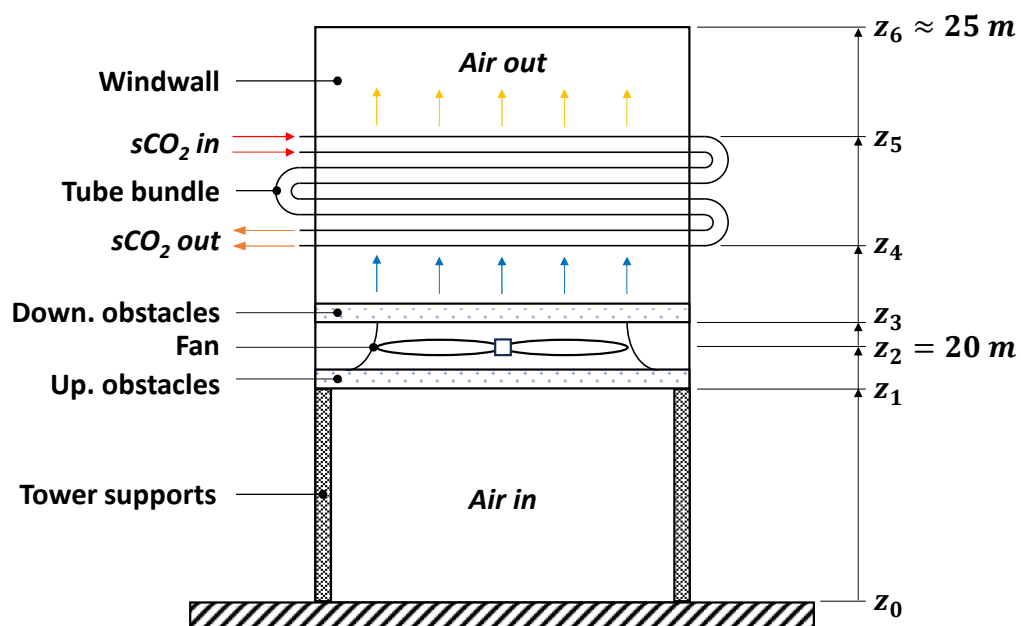

CF-8.8-1.0J A/B
Kays & London (2018)

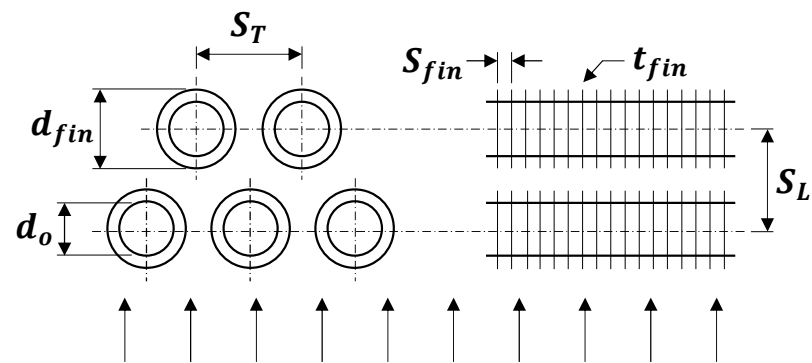

Schedule 10 ASTM A106 Grade B piping
OD = 26.7 mm
wt = 2.11 mm

sCO₂ ACHE System

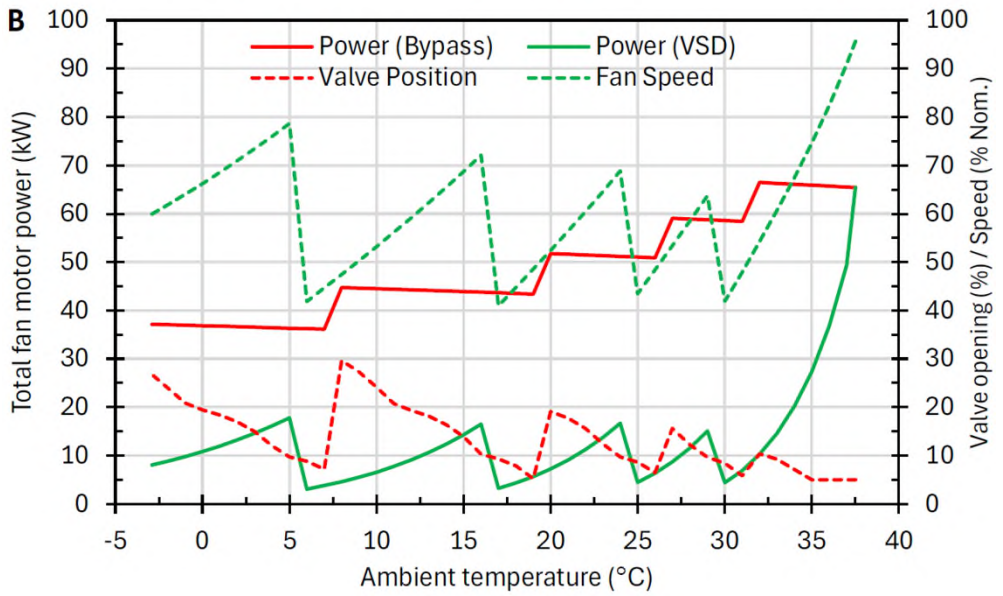
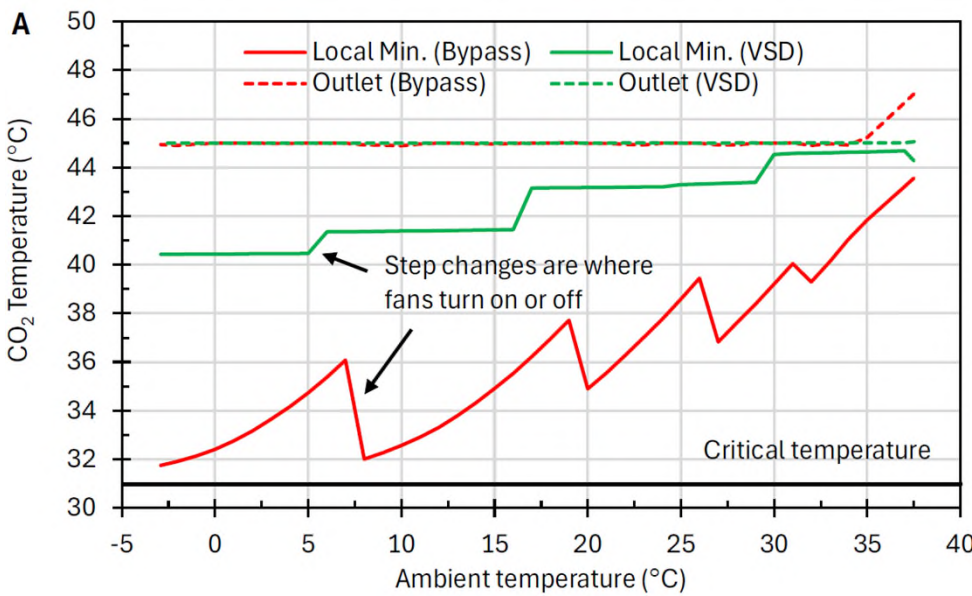

sCO2 axial fan development

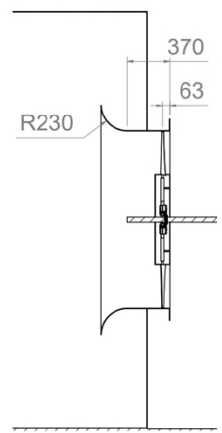
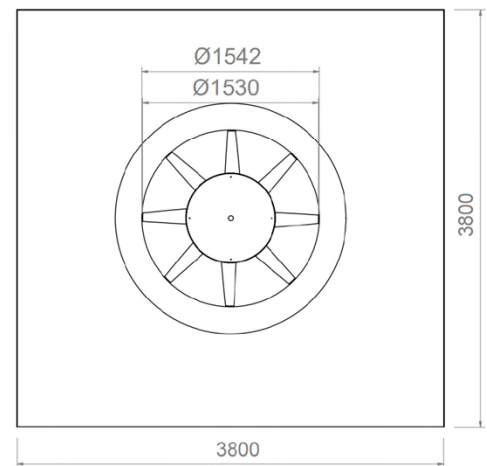
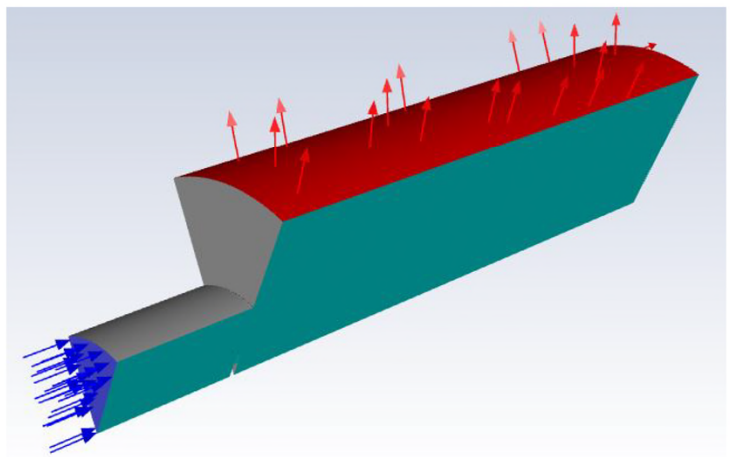
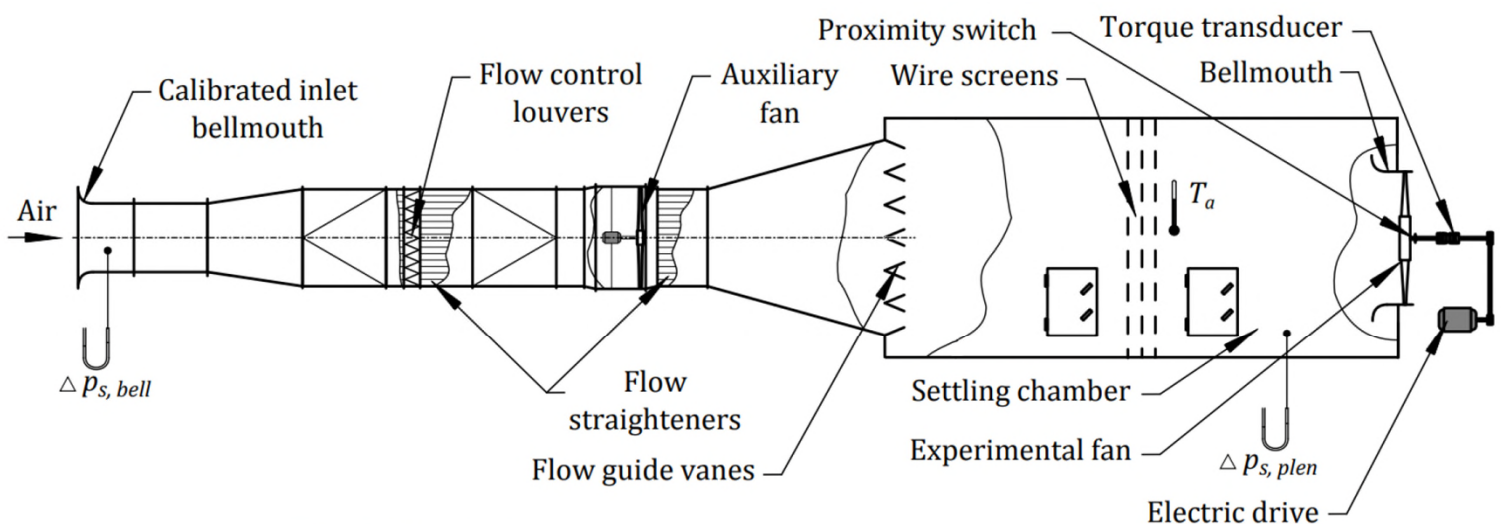

sCO2 axial fan development

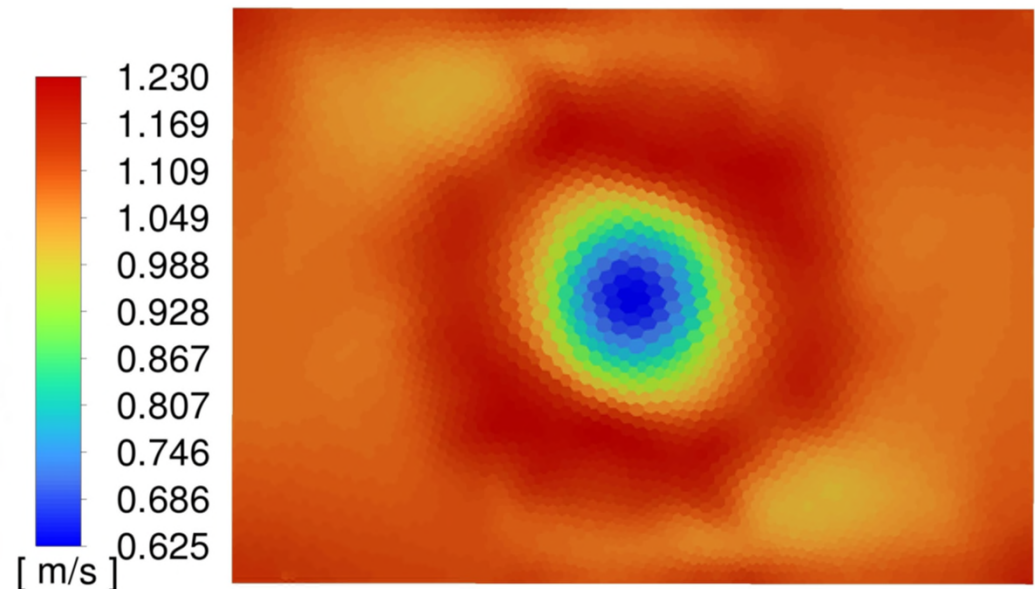
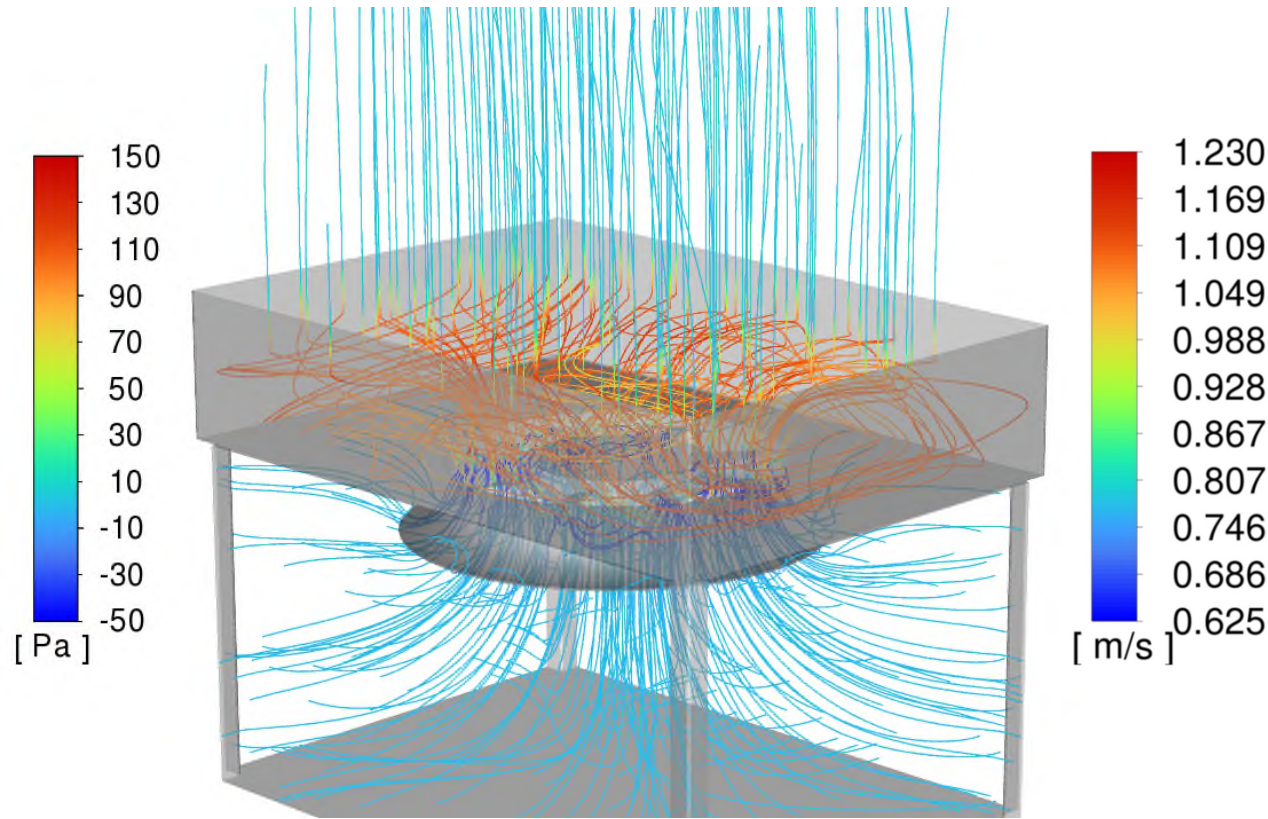

Co-simulation for sCO₂ NDDCT

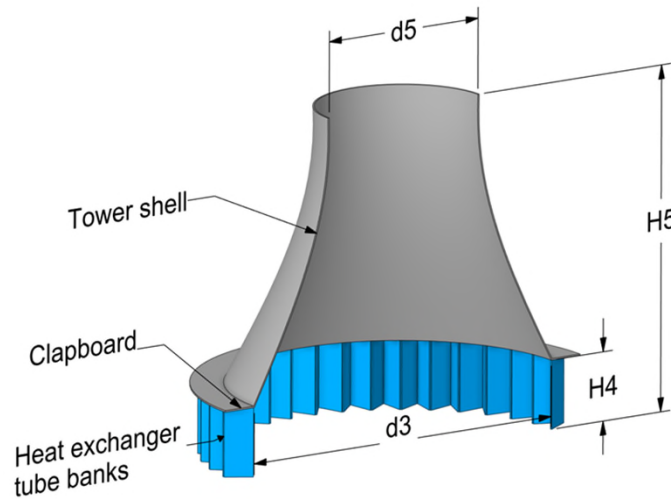

Overall dimensions of cooling tower



Side view of a single heat exchanger tube bank

| Parameter | Symbol | Value |
|------------------------|--------|-------|
| Total tower height (m) | H_5 | 55.79 |
| Inlet height (m) | H_4 | 11.14 |
| Inlet diameter (m) | d_3 | 55.79 |
| Outlet diameter (m) | d_5 | 27.89 |

Co-simulation for sCO₂ NDDCT



No wind: Pressure inlet
Wind: Velocity inlet

Pressure outlet

No wind: Pressure inlet
Wind: Pressure outlet

Symmetry

Wall

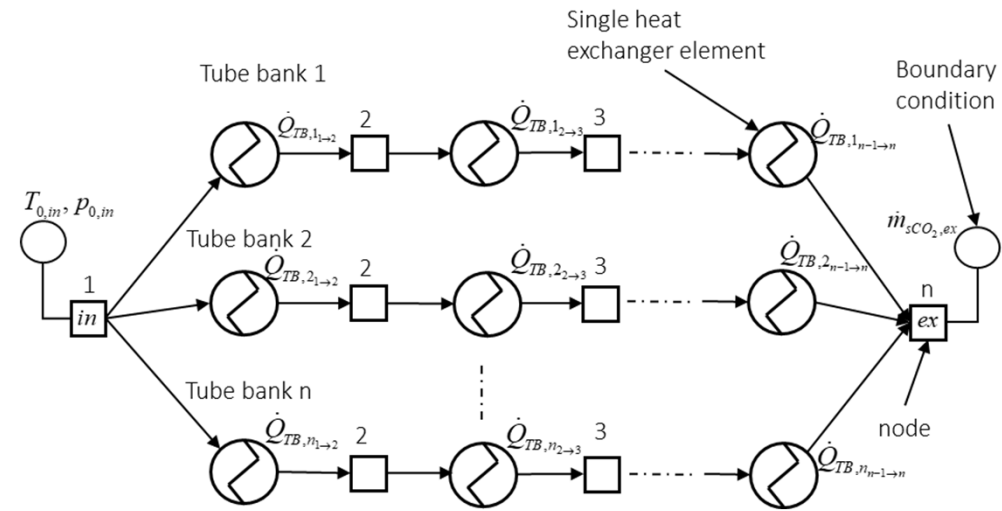
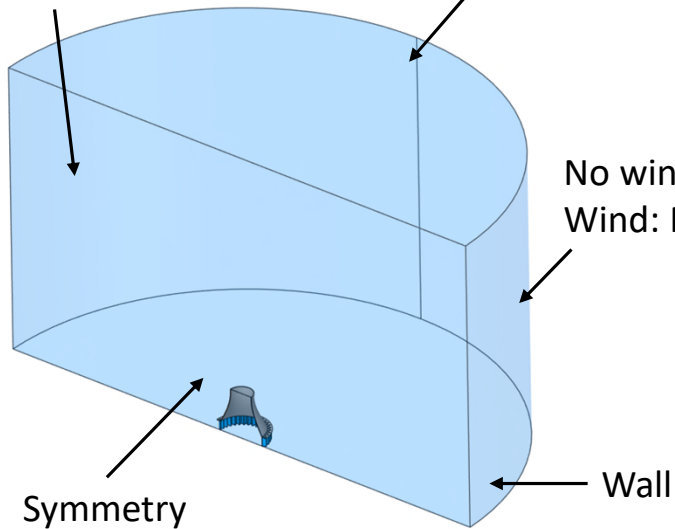

Co-simulation for sCO₂ NDDCT

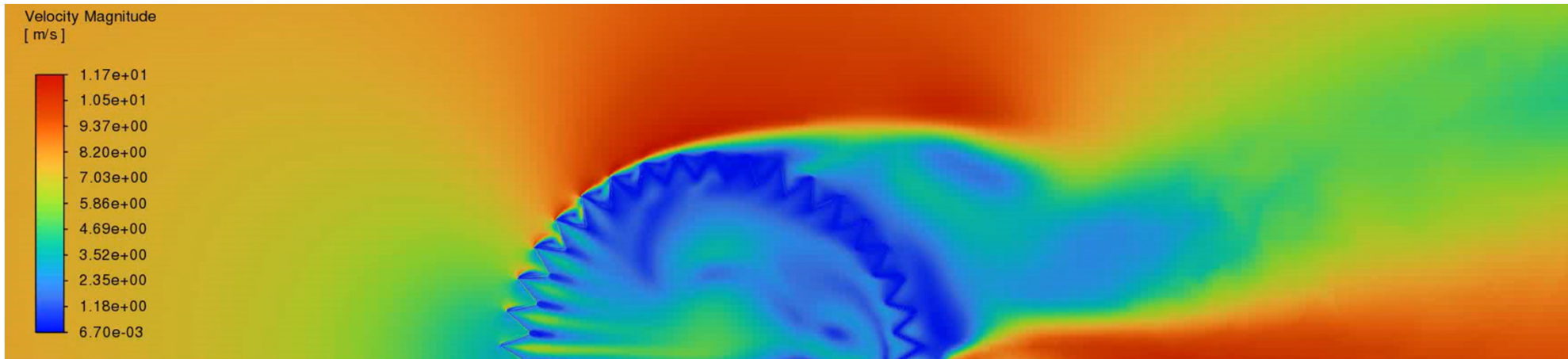
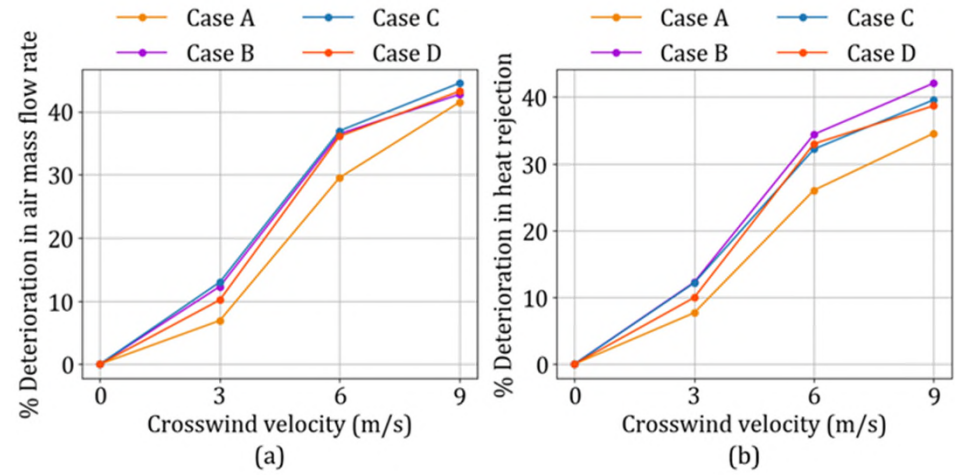
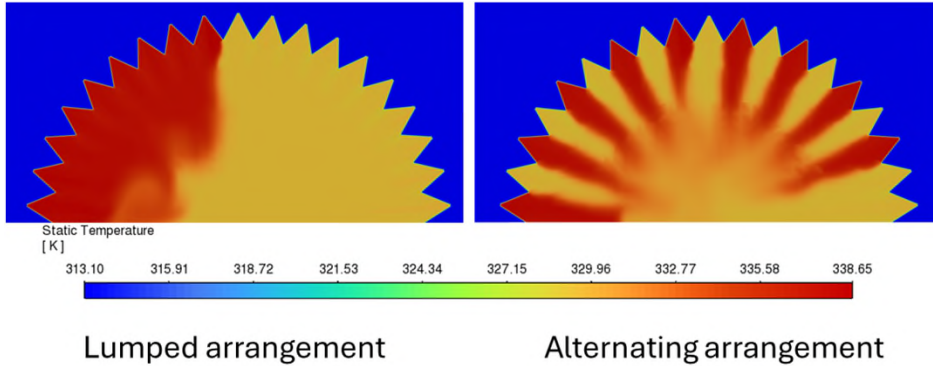

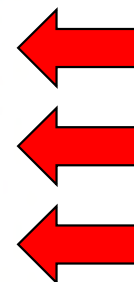

Current
 General operating budget
 Minimal interest locally

<https://www.twi-global.com/technical-knowledge/faqs/technology-readiness-levels>



Next steps

Industry partner for:
Air-cooled systems hardware; Software-based simulators and/or condition monitoring systems.

<https://www.twi-global.com/technical-knowledge/faqs/technology-readiness-levels>

sCO₂ publications



Conference papers

Abrahams, L., du Sart, C. & Laubscher, R. 2022. Design of an air-cooled heat rejection system for a sCO₂ concentrated solar power plant. In *16th international conference on heat transfer, fluid mechanics and thermodynamics (HEFAT-16)*. Virtual: HEFAT.

Boshoff, F.D., van der Spuy, S.J., Pretorius, J.P. & Meyer, C.J. 2022. Design of an Axial Flow Fan for a Unique Cooling Application. In *Proceedings of ASME Turbo Expo 2022*. Rotterdam: ASME.

Boshoff, F.D., van der Spuy, S.J. & Pretorius, J.P. 2024. Axial Flow Fan Performance in a Forced Draught Air-Cooled Heat Exchanger for a sCO₂ Brayton Cycle. In *Proceedings of the ASME Turbo Expo 2024*. London: ASME.

Boshoff, F.D., Van der Spuy, S.J., Pretorius, J.P. & Laubscher, R. 2025. Co-simulation of an axial flow cooling fan in a supercritical CO₂ air-cooled heat exchanger. In *Fan2025: International Conference on Fan Noise, Aerodynamics, Applications and Systems*. Antibes Juan-Les-Pins.

De Villiers, C., Laubscher, R., Rousseau, P. & Pretorius, J. 2025. Preliminary design and sensitivity analysis of centrifugal compressor train for a 50 MWe sCO₂ Brayton power cycle for CSP applications. In *The 6th European sCO₂ Conference for Energy Systems*. Delft.

du Sart, C.F., Rousseau, P.G. & Laubscher, R. 2021. Cycle selection and system-level optimization of a 50 MWe sCO₂ CSP plant. In *Proceedings of the 15th international conference on heat transfer, fluid mechanics and thermodynamics (HEFAT-15)*. Virtual: HEFAT.

du Sart, C.F., Rousseau, P. & Laubscher, R. 2024. A method to develop centrifugal compressor performance maps for off-design and dynamic simulation studies of sCO₂ cycles. In *Proceedings of the 8th International Supercritical CO₂ Power Cycles Symposium*. San Antonio.

sCO₂ publications



Conference papers (ctd.)

du Sart, C., Rousseau, P. & Laubscher, R. 2024. A method to develop radial inflow turbine performance maps for off-design and dynamic simulation studies of sCO₂ cycles. In *Proceedings of ASME Turbo Expo 2024*. London: ASME.

du Sart, C. & Rousseau, P. 2025. Thermofluid design and off design performance of an air-cooled heat exchanger system for a 50 MWe sCO₂ CSP Plant. In *The 6th European sCO₂ Conference for Energy Systems*. Delft.

Heydenrych, J.M., Rousseau, P.G. & du Sart, C.F. 2022. Reduced-order modelling of central solar tower receivers using an equivalent thermal resistance network. In *Proceedings of the 16th international conference on heat transfer, fluid mechanics and thermodynamics (HEFAT-16)*. Virtual: HEFAT.

Heydenrych, J.M., Rousseau, P.G. & du Sart, C.F. 2023. A reduced order modelling methodology for concentrated solar power external cylindrical receivers. In *Proceedings of the 17th international heat transfer conference (IHTC-17)*. Cape Town: Begell House.

Tshamala, M.C., Moyo, T., Owen, M.T.F. & McGregor, C. 2023. Feasibility Study of a Supercritical Carbon Dioxide Brayton Recompression Cycle Cooled by a Vapor Compression Refrigeration Cycle. In *Proceedings of the 17th international heat transfer conference (IHTC-17)*. Cape Town: Begell House.

Tshamala, M.C., Govender, C., Hans, T.M., Owen, M.T.F. & McGregor, C. 2022. Thermodynamic analysis of a 20 MW concentrated solar-powered supercritical carbon dioxide Brayton recompression cycle. In *Proceedings of the 16th international conference on heat transfer, fluid mechanics and thermodynamics (HEFAT-16)*. Virtual: HEFAT.

sCO₂ publications



Conference papers (ctd.)

Tshamala, M.C., Moyo, T., Owen, M.T.F. & McGregor, C. 2023. Feasibility Study of a Supercritical Carbon Dioxide Brayton Recompression Cycle Cooled by a Vapor Compression Refrigeration Cycle. In *Proceedings of the 17th international heat transfer conference (IHTC-17)*. Cape Town: Begell House.

Tshamala, M.C., Owen, M., McGregor & C., Dlamini, Z. 2023. Feasibility Study on the Use of a Water-Cooled Shell and Tube Heat Exchanger for a sCO₂ Brayton Recompression Cycle in CSP Applications. Southern African Sustainable Energy Conference (SASEC 2023). Port Elizabeth.

Van Niekerk, C.H., Pretorius, J. & Laubscher, R. 2025. Thermofluid Network Simulation of a Natural Draft Direct Dry Cooling System for a 50 MWe sCO₂ Power Cycle for CSP Application. In *The 6th European sCO₂ Conference for Energy Systems*. Delft.

sCO₂ publications



Journal papers

Boshoff, F.D., van der Spuy, S.J., Pretorius, J.P. & Meyer, C.J. 2024. Investigation into the predicted performance of a cooling fan for an sCO₂ CSP plant. *IMEchE Journal of Power and Energy* 10(2)

Boshoff, F.D., Van der Spuy, S.J. & Pretorius, J.P. 2025. Axial Flow Fan Performance in a Forced Draught Air-Cooled Heat Exchanger for a Supercritical Carbon Dioxide Brayton Cycle. *ASME Journal of Engineering for Gas Turbines and Power* 147(1).

du Sart, C.F., Rousseau, P. & Laubscher, R. 2024. Comparing the partial cooling and recompression cycles for a 50 MWe sCO₂ CSP plant using detailed recuperator models. *Renewable Energy* 222.

Haffejee, R.A., Rousseau, P. & Laubscher, R. 2024. Integrated Performance of a Modular Biomass Boiler With a Combined Heat and Power Industrial Rankine Cycle and Supplementary sCO₂ Brayton Cycle. *Journal of Thermal Science and Engineering Applications* 16(9).

Haffejee, R.A., Rousseau, P. & Laubscher, R. 2025. Part-Load Performance Analysis of a Modular Biomass Boiler With a Combined Heat and Power Industrial Rankine Cycle and Supplementary sCO₂ Brayton Cycle. *Journal of Thermal Science and Engineering Applications* 17(1).

Haffejee, R.A., Rousseau, P. & Laubscher, R. 2025. Investigation into overfiring of a modular biomass boiler with an industrial Rankine cycle and supplementary sCO₂ Brayton cycle using CFD. *International Journal of Thermofluids* 27.

sCO₂ publications



Journal papers (ctd.)

Laubscher, R., Rousseau, P., Van Der Spuy, J., du Sart, C. & Johannes, P. 2024. Development of a 1D network-based momentum equation incorporating pseudo advection terms for real gas sCO₂ centrifugal compressors which addresses the influence of the polytropic path shape. *Thermal Science and Engineering Progress* 55.

Laubscher, R., Rousseau, P., Johannes, P., du Sart, C. & Van Der Spuy, J. 2025. Design analysis of high and low loaded high- and low-pressure axial-flow turbines for a single shaft 50 MWe supercritical carbon dioxide Brayton power cycle. *Applied Thermal Engineering* 274.

Van Niekerk, C.H., Pretorius, J. & Laubscher, R. 2026. Performance of a natural draft direct dry cooling system for a supercritical CO₂ power cycle using a coupled simulation approach. *Applied Thermal Engineering* 288(2).

sCO₂ publications



Masters dissertations

Abrahams L. 2024. Thermofluid design and performance analysis of an air-cooled heat rejection system for a 50 MWe sCO₂ concentrated solar power plant. University of Cape Town, Faculty of Engineering and the Built Environment, Department of Mechanical Engineering.

Heydenrych J. 2023. A reduced order modelling methodology for external cylindrical concentrated solar power central receivers. University of Cape Town, Faculty of Engineering and the Built Environment, Department of Mechanical Engineering.

Doctoral dissertations

Boshoff, F.D. 2025. Forced draught supercritical carbon dioxide cooling system performance. Stellenbosch University, Faculty of Engineering, Department of Mechanical and Mechatronic Engineering.

du Sart, C.F. 2025. Thermofluid design and dynamic simulation of an sCO₂ power cycle for a 50 MWe concentrated solar thermal tower plant in Southern Africa. University of Cape Town, Faculty of Engineering and the Built Environment, Department of Mechanical Engineering.

Haffejee R. 2025. A biomass-fueled combined steam and sCO₂ heat and power cycle for Southern African conditions. University of Cape Town, Faculty of Engineering and the Built Environment, Department of Mechanical Engineering.