



Cycle and component modeling



Cycle analysis

- System models that are used to:
 - Estimate and optimize overall system performance
 - Trade cost and performance
 - Provide boundary conditions for components
 - Evaluate operability
 - Design and optimize controls



Cycle model basics

- Fundamental tool to predict performance of a collection of components in a thermodynamic system
- Main principles
 - Conserve mass and energy
 - Define the components with adequate detail
 - Constrain the solution appropriately
 - If $N_{\text{var}} = N_{\text{DOF}}$, you are solving for a single unique solution
 - If $N_{\text{var}} > N_{\text{DOF}}$, you are solving a non-linear optimization problem

Optimization problems are the norm – usually performance and/or cost



Design models vs performance models

- Design model
 - Boundary conditions (e.g. heat source, heat sink) known at design point
 - Objective: Find arrangement of components that produces some form of optimal outcome
 - Performance
 - Cost
 - Other constraints (e.g. footprint, max P)
- Performance model
 - BCs cover range of values
 - Objective: With a given arrangement of fixed components, find optimal operating state of machine

Example of a closed-loop cycle & components

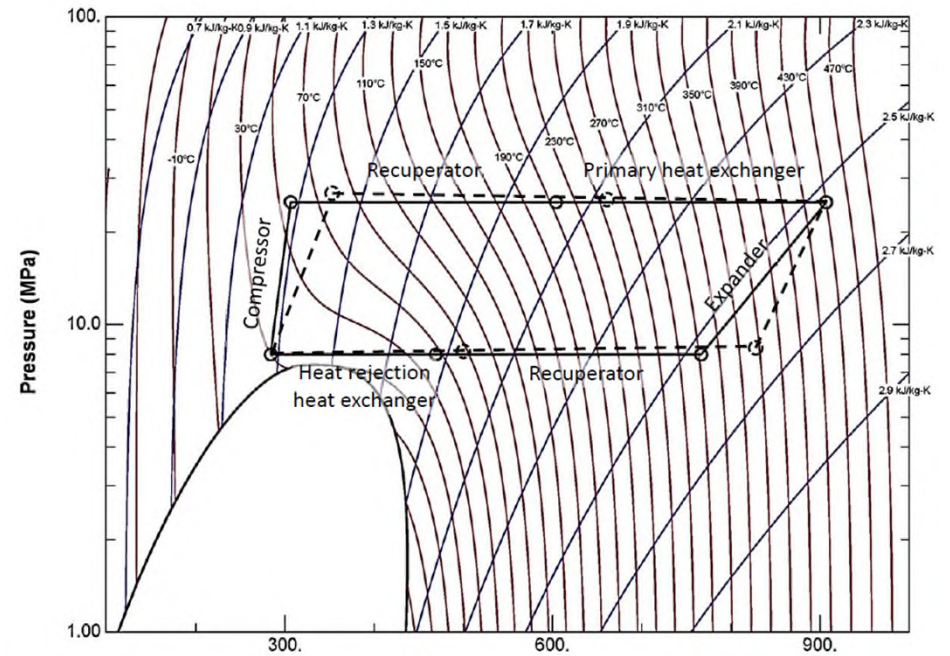
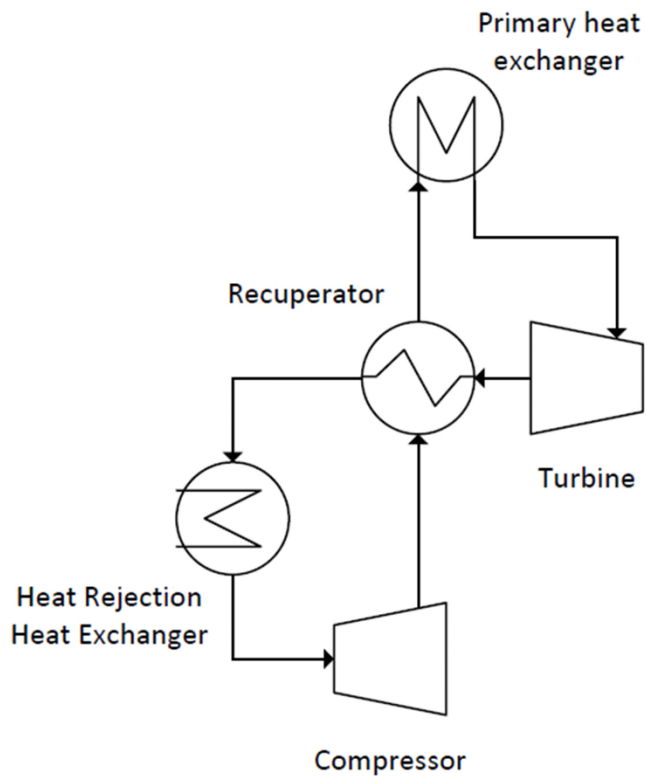

RCB cycle designed for recirculated heat applications with low ΔT

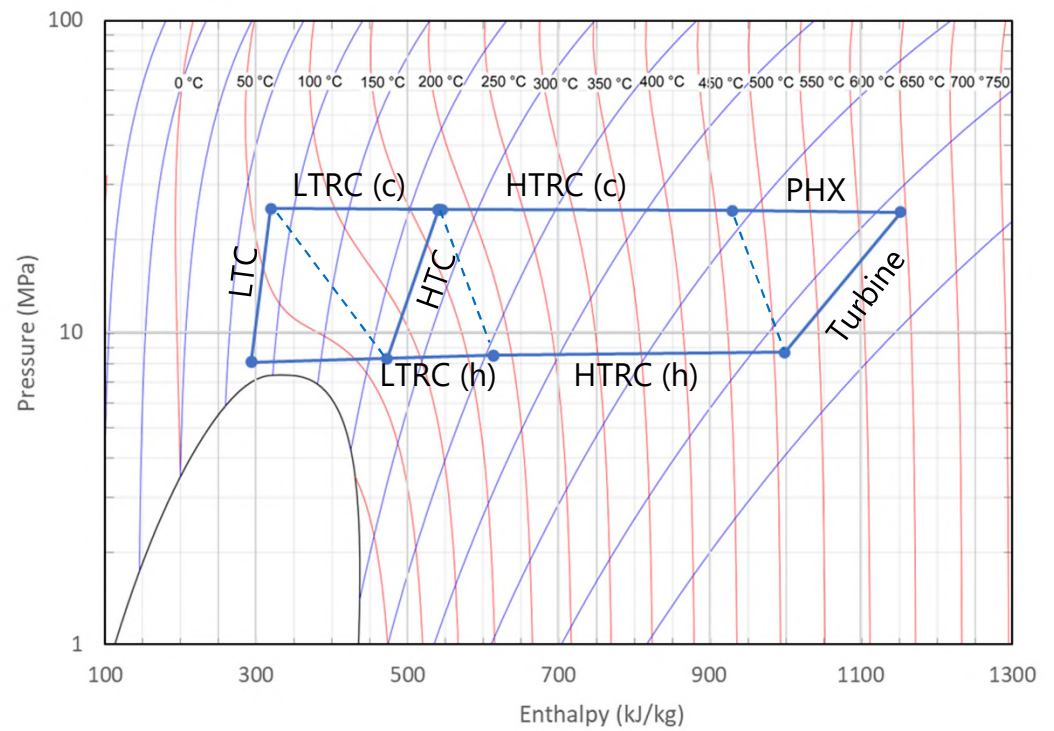
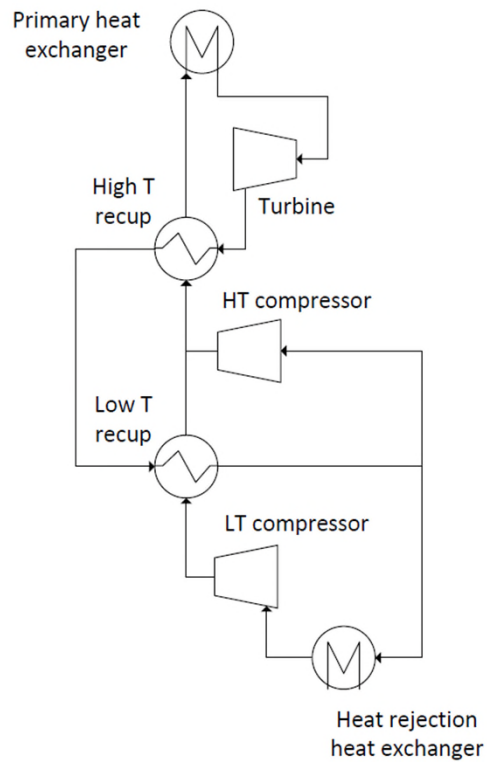

Component operating conditions affect how you model them

Compressors operate in highly non-ideal-gas conditions

Turbines operate in near ideal-gas conditions

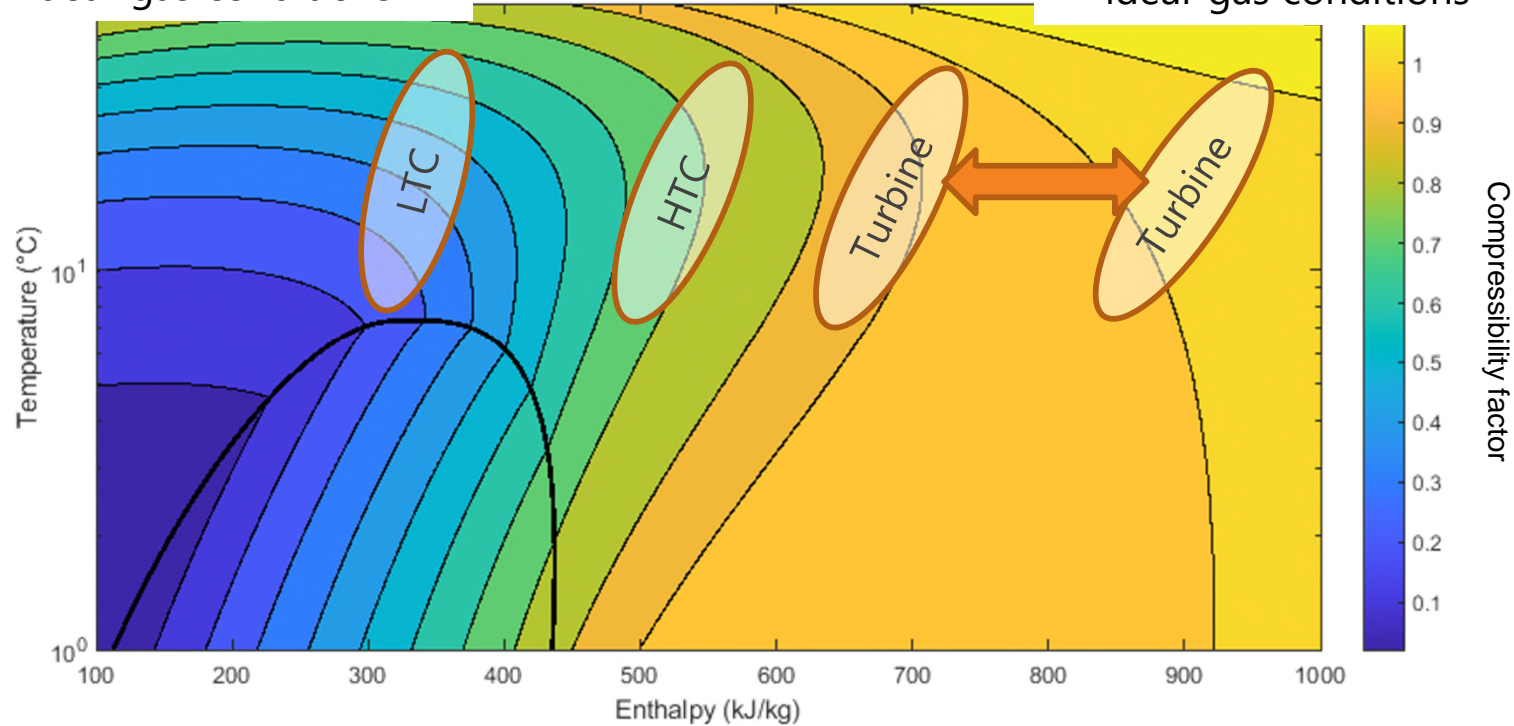



Compressor & turbine modeling

- Design mode
 - Inputs:
 - Pressure ratio
 - Flow rate
 - Inlet conditions
 - Isentropic (or polytropic) efficiency
 - Outputs
 - Shaft work
 - Discharge conditions
- Performance mode
 - Inputs:
 - Compressor map
 - Inlet conditions
 - Speed
 - Outputs
 - Shaft work
 - Discharge conditions

Compressor in cycle design mode

- Know : p_1, T_1, p_2 and \dot{m}
 - $h_{2s} = h(p_2, s_1)^*$
 - $h_2 = h_1 + \frac{h_{2s} - h_1}{\eta_s}$
 - $T_2 = T(h_2, p_2)$
 - $W = \dot{m}(h_1 - h_2)$
- Compressor efficiency is an assumption – needs to be consistent with capability

Turbine in cycle design mode

- Know : p_1, T_1, p_2 and \dot{m}
 - $h_{2s} = h(p_2, s_1)$
 - $h_2 = h_1 - \eta_s(h_{2s} - h_1)$
 - $T_2 = T(h_2, p_2)$
 - $W = \dot{m}(h_1 - h_2)$
- Turbine efficiency is an assumption – needs to be consistent with capability

Polytropic vs isentropic efficiency

- Thermodynamics & cycle modeling wants isentropic efficiency
- Compressor designers talk in “polytropic efficiency” (efficiency for an incremental change in pressure)
- Can convert between them:

- $$\eta_s = \frac{1-PR^{\eta_p \frac{\gamma-1}{\gamma}}}{1-PR^{\frac{\gamma-1}{\gamma}}}$$

but what do you use for γ when your fluid is not an ideal gas?

(hint, it's not $\frac{c_p}{c_v}$)

Polytropic vs isentropic efficiency

- Managing variation in properties – small stage method
- Numerical integration over the compression process:

$$h_e = h_i + \int_{p_i}^{p_e} \eta_p^{-1} \frac{dh_s(p)}{dp} dp$$

Evans, B. F., and Huble, S. R., 2017, "Centrifugal Compressor Polytropic Performance: Consistently Accurate Results from Improved Real Gas Calculations," *ASME GT Expo*, Charlotte, North Carolina, Paper GT2017-65235.

<https://doi.org/10.1115/GT2017-65235>.

Compressor performance modeling – maps

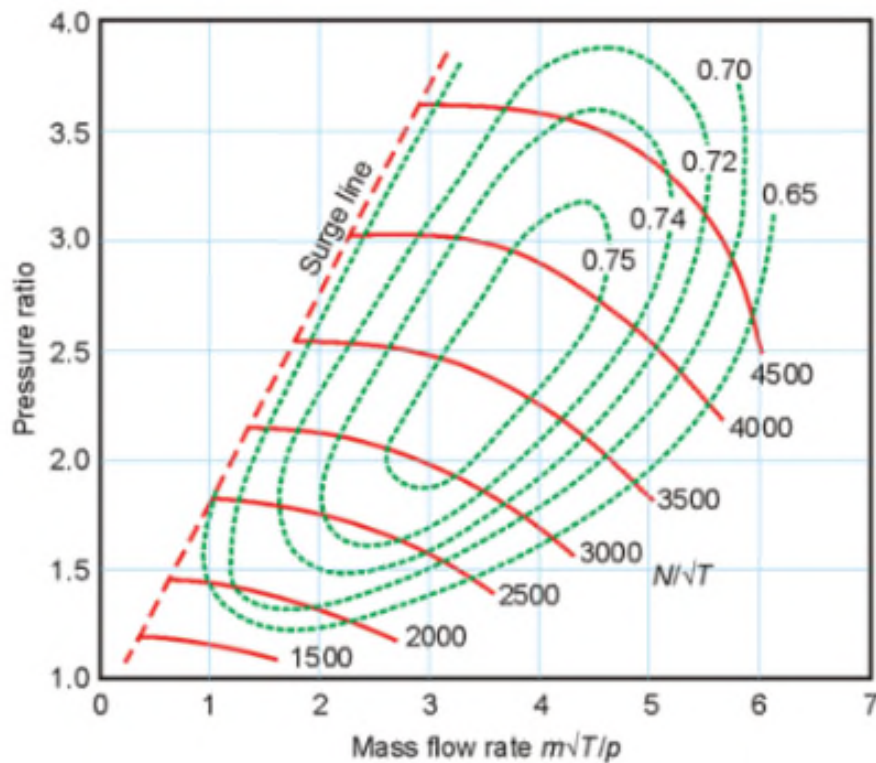

From ConceptsNREC website

Given inlet conditions and speed, can output pressure ratio and efficiency

Standard approach bakes in ideal gas assumptions

Real gas (and dense-ish) fluid effects are more subtle. See, for example:

Pham, H. S. *et al.*, 2016, International Journal of Heat and Fluid Flow, **61**, pp. 379–394.

Variable inlet guide vanes add another dimension to maps

Turbine performance modeling – maps

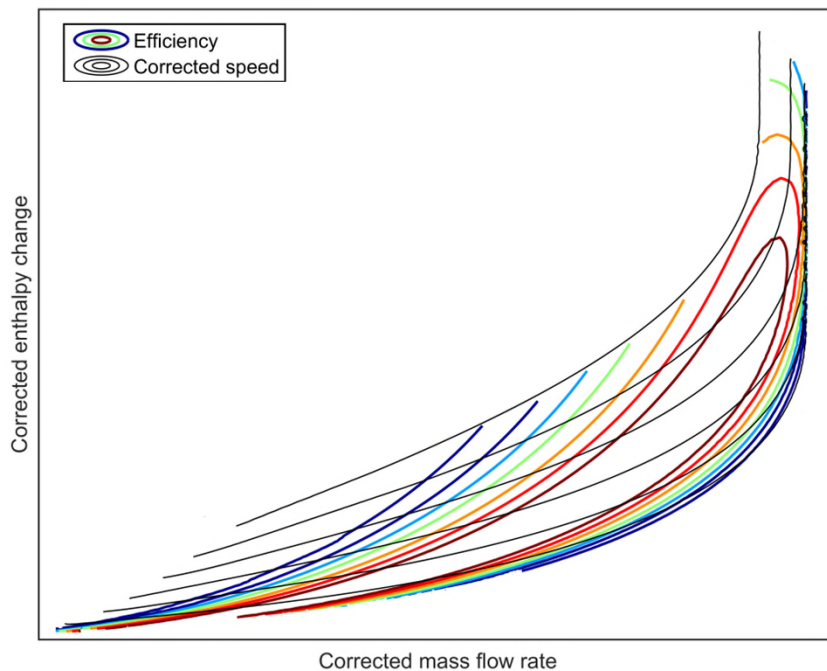

Given inlet conditions and speed, can output pressure ratio and efficiency

Standard approach bakes in ideal gas assumptions

Real gas fluid effects are more subtle. See, for example, BNI's approach documented in Appendix B of:

Gavagnin, G., *et al.*, 2018, Applied Energy, **231**, pp. 660–676,
url=<https://linkinghub.elsevier.com/retrieve/pii/S030626191831451X>

Variable inlet guide vanes add another dimension to maps



Heat exchangers

- 3 major categories:
 - Recuperators: Internal heat transfer (CO_2 to CO_2)
 - External heat addition: X to CO_2
 - External heat rejection: CO_2 to ambient (air or water)
- Common types for CO_2 :
 - PCHE/DBHE
 - Multi-bank finned tube
 - Shell & tube

Heat exchanger component models

- Traditional approaches:
- Effectiveness/NTU
- UA LMTD
 - Both only work under constant c_p assumption
 - Bad assumption for CO_2 most of the time

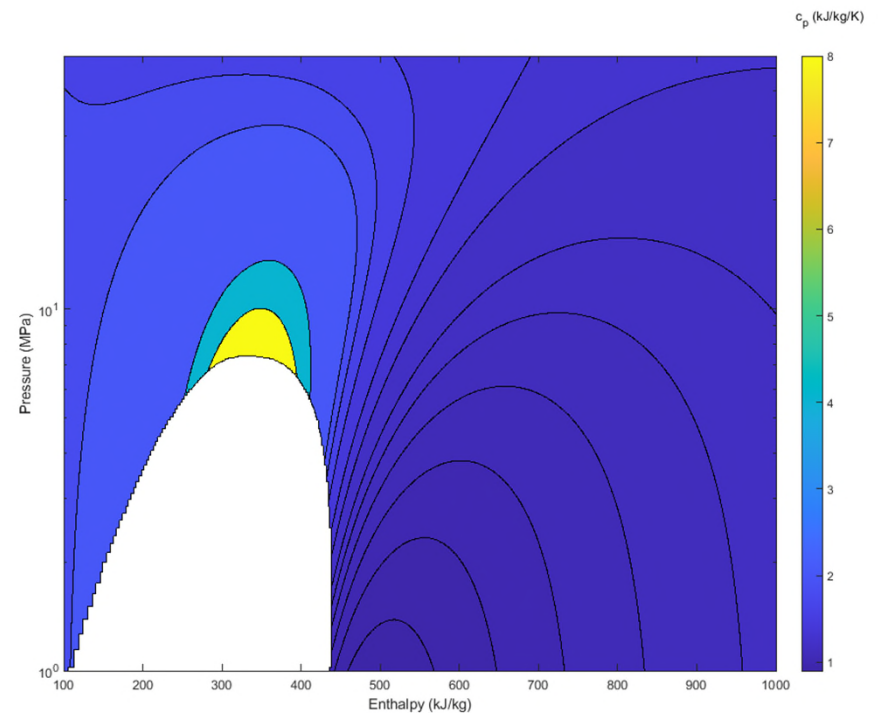

Heat exchanger design point modeling - basic concepts

TQ plot example:

- Slope of curve is proportional to $(\dot{m}c_p)^{-1}$
- Ideal fluid with constant c_p , curves would be straight lines
- Real fluids have curves, and if the streams cross...

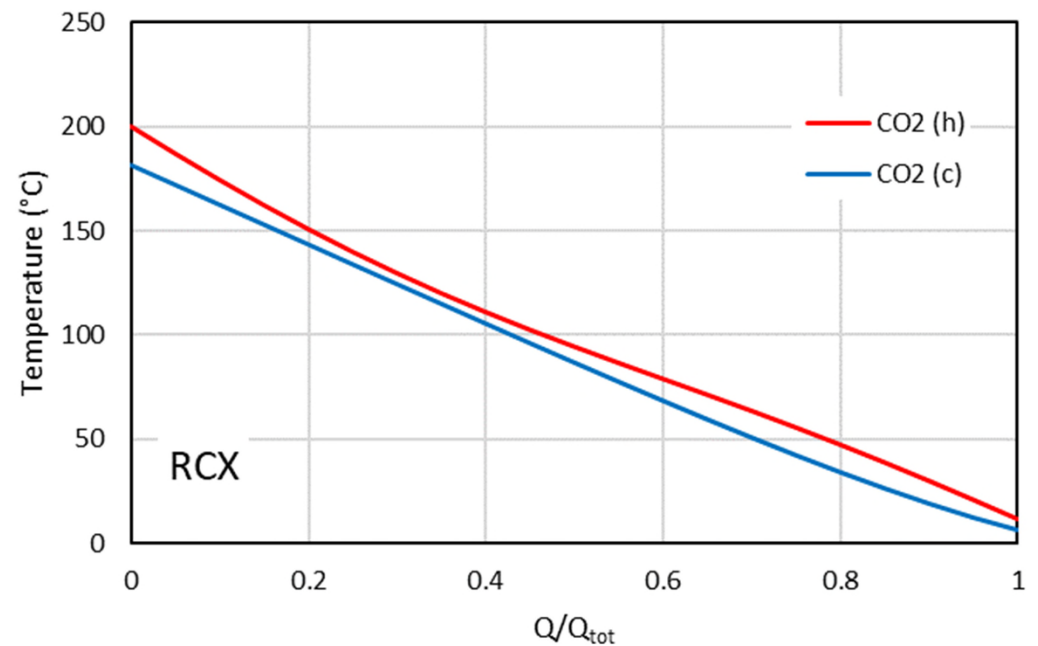



Heat exchanger design point modeling – more basics

- Heat transfer can be modeled as:

$$Q_h = -Q_c = \frac{\Delta T}{R} = UA \Delta T,$$

where R is a thermal resistance term that includes heat transfer area

and UA is the “conductance” of the heat exchanger

Heat exchanger design point modeling – one way

- Divide (discretize) heat exchanger into I segments

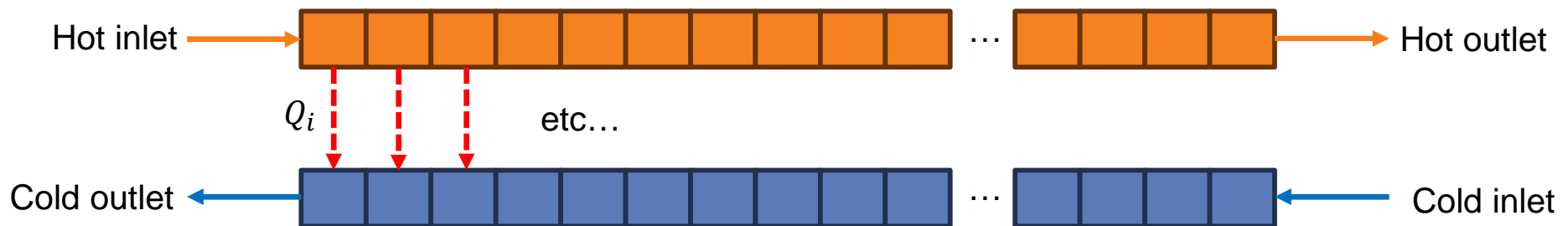

- By making I large enough, c_p of the fluids are reasonably constant in each interval, so we can write

$$Q = \sum_{i=1}^I dQ_i = \sum_{i=1}^I UA_i \Delta T_i$$

Heat exchanger design point modeling – Design mode

- Option 1: Specify a UA target
 - Given a set of inlet conditions (p, T, \dot{m}) , assume a set of outlet conditions such that $Q_h = -Q_c$
 - Calculate $Q_{total} = \dot{m}\Delta h$
 - Divide both sides into I segments of equal Q_i
 - Calculate $T_i = T(p, h_i)$
 - From preceding slide, $UA = \sum UA_i = \sum \frac{dQ_i}{\Delta T_i}$
 - Iterate on outlet conditions until $UA = \text{target value}$
- Other options include setting an effectiveness target or minimum temperature difference – iterative processes are similar
- Specified dP – check with suppliers to find out what is reasonable

Heat exchanger design point modeling continued

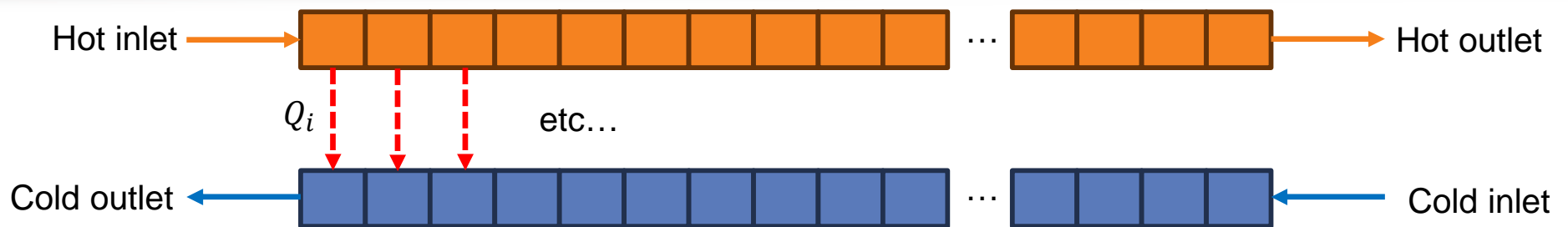

- Concept only applies to counterflow geometry
 - DBHEs are close to pure counterflow, but not exactly
- Cross-flow heat exchangers are common in air-to-CO₂ applications
 - If number of passes is > 3 or 4 , counterflow isn't a bad approximation
 - More complex discretized solutions are possible, but might not be worth the effort – consider an effectiveness limit based on NTU

Heat exchanger modeling – performance

- Similar to design-point specified-UA technique
- Correct UA to off-design conditions

$$R = R_{conv,h} + R_{cond} + R_{conv,c}$$
$$R_{conv,h} = (h_{conv,h} A_{h,h})^{-1}$$

...etc

using your favorite heat transfer correlation(s) ($Nu = hd/k = f(Re, Pr, \dots)$), ratioed to design point

- Correct dP using a similar approach:

$$dP = \frac{f(Re)}{d} \frac{\rho}{2} U^2 L$$

Oxy-fuel combustion in CO₂

- Standard equilibrium solvers (e.g. Chemkin, ASPEN) will manage $T(h_{in}, X_f, X_o)$ problem
- Kinetics simulations – wide-open problem!

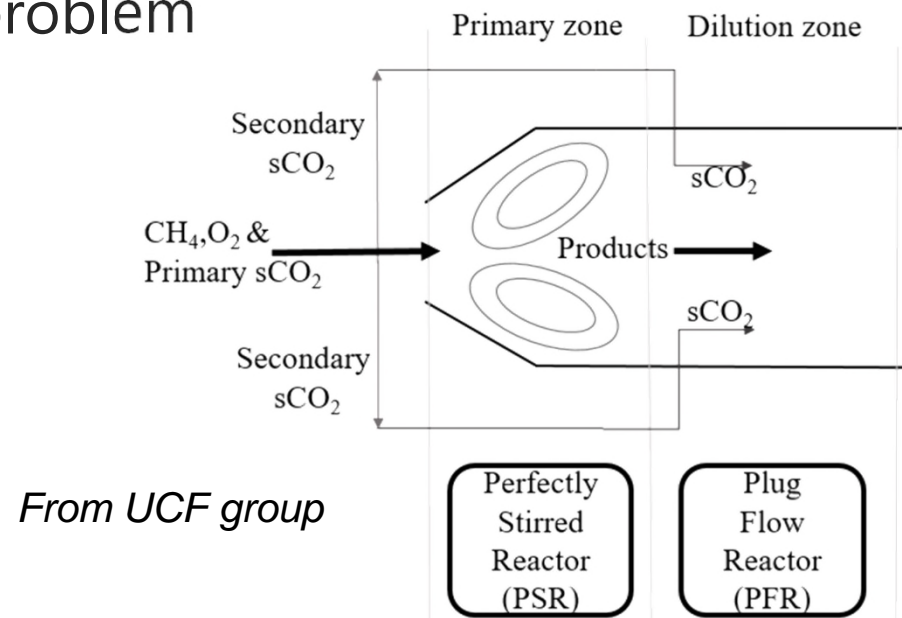



Other modeling tips

- Heat losses can be significant, especially in small systems – consider including in modeling
- Piping pressure drops are also important, model similarly to heat exchanger dP
- Control valves are frequently necessary to adjust flow splits and have non-zero dP even when full open
- Secondary / auxiliary loads need accounting
 - Cooling fans, pumps, etc.
 - Seal gas conditioning systems
 - Lube oil cooling
 - Generator, gearbox, VFD, switchgear losses

Fluid properties

- Span & Wagner EOS for CO₂ is industry standard
- New EOS has been created (Harvey and Lemmon, 2022 sCO₂ Symposium) – release date TBD (but not imminent)
- REFPROP, CoolProp both use S&W
 - Generally good for pure CO₂
 - Mixture properties less certain
 - Execution speed can be problematic
 - 2-D table lookups a common approach
 - Interpolation behavior near saturation line can be a problem
 - $h_{\text{lookup}} = h(T_{\text{spec}}, P)$, $T_{\text{lookup}} = T(h_{\text{lookup}}, P)$, ... $T_{\text{lookup}} - T_{\text{spec}} \neq 0!$
 - Not necessarily the end of the world, but can be a problem if you expected that behavior

Cost modeling

- Core function of practical modeling – cost/performance trades

- Key cost variables:

Cycle complexity
Heat exchanger sizing

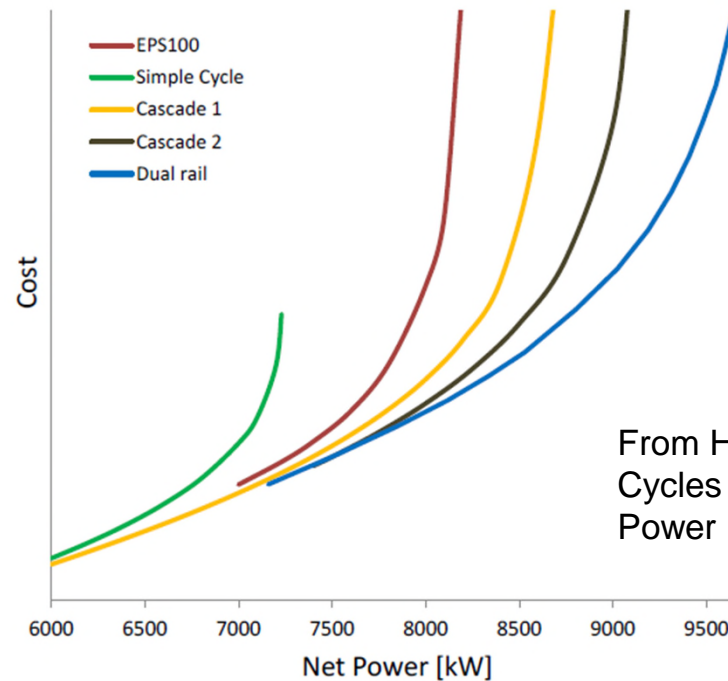

From Held, 2015, "Supercritical CO₂ Cycles for Gas Turbine Combined Cycle Power Plants," *Power Gen International*.

Cost modeling (continued)

- Typical cost models:

$$C = A + B \cdot SP^n$$

where “*SP*” is a scaling parameter (e.g., UA for heat exchangers, power output for turbines, etc.), *A*, *B* and *n* are fit parameters

- Weiland paper is an excellent source for fit parameters – recognizing that 2024 prices are 1.3 to 1.5X vs 2019

Weiland, Lance and Pidaparti, “sCO₂ Power Cycle Component Cost Correlations from DOE Data Spanning Multiple Scales and Applications,” *ASME Turbo Expo 2019*, Paper GT2019-90493

Modeling tools and techniques

- Hand draw on a PH diagram – great way to get into the ballpark

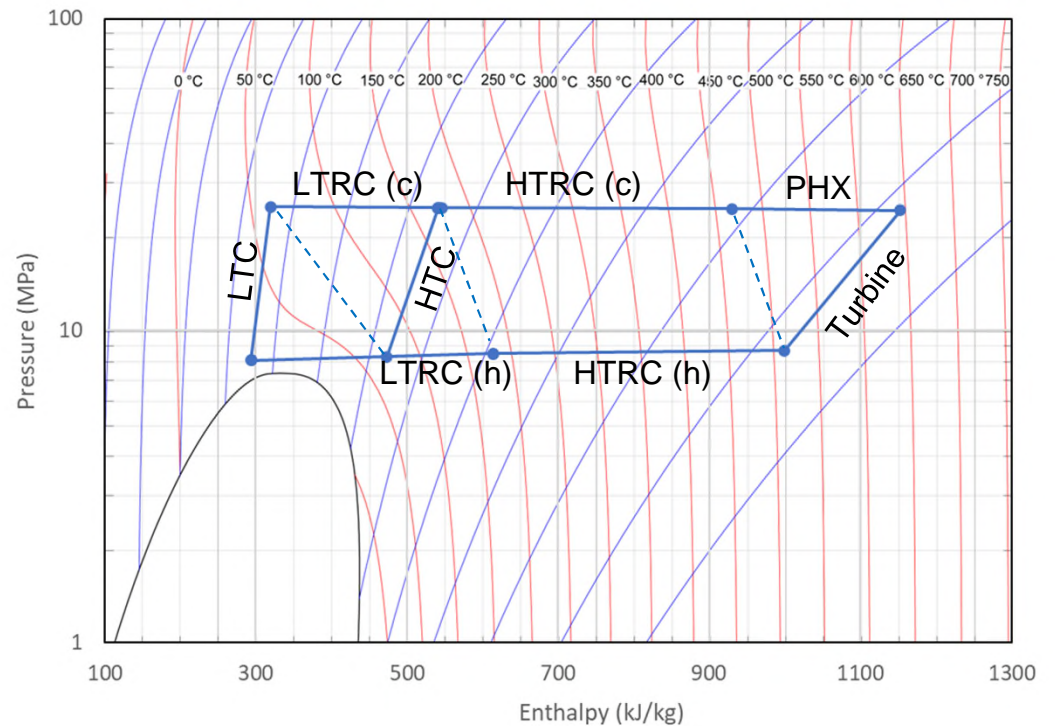

Modeling tools - Constraints

- Non-linear optimizers need boundaries – and a good initial guess

Variables	x	LB	UB	x0
P1	8.05	7	12	8
P2	24.99	10	25	25
T1	31.73	28	60	30
T31	175.36	100	400	170
T34	468.17	200	600	450
T4	645.93	600	650	640
wltc	599.28	5	800	600
whtc	363.18	0.1	400	350

Constraints		LB	UB
LTC margin	1.052	0.3	
UALTR	21636		40000
UAHTR	15395		30000
UAACC	18907		20000
UAPHX	1648		10000
Wnet	100643	100000	100001
HX cost	52,970,721		54,000,000



Modeling tools – not an exhaustive list!

- Commercial codes
 - ASPEN, HYSYS, Ebsilon, GateCycle, IPSEPro, AxSTREAM, CYCAL, NPSS, Flownex, Modelon
- Open-source codes
 - OpenMDAO/PyCycle, T-MATS, others?



Transient modeling

- Simulation purposes:
 - System responses to changes in power demand, heat supply, heat sink temperature
 - Control system design and optimization
 - Startup/normal shutdown
 - Event simulation – e-stops, PRV releases, pipe ruptures
 - Define transient BCs for components, transient stress analysis
- Significantly more challenging numerically, computationally
- Requires at least a rudimentary control system layout
- Requires component off-design models
- Steady-state models + transient terms
 - Thermal inertia
 - Mechanical inertia
 - Volume dynamics (fluid inertia)

Transient model example

- Model construction similar to steady-state model
- Setting up BCs and ICs crucial to finding valid solution

From Avadhanula and Held, "Transient Modeling of a Supercritical CO₂ Power Cycle and Comparison with Test Data," *ASME Turbo Expo 2017, GT2017-63279*

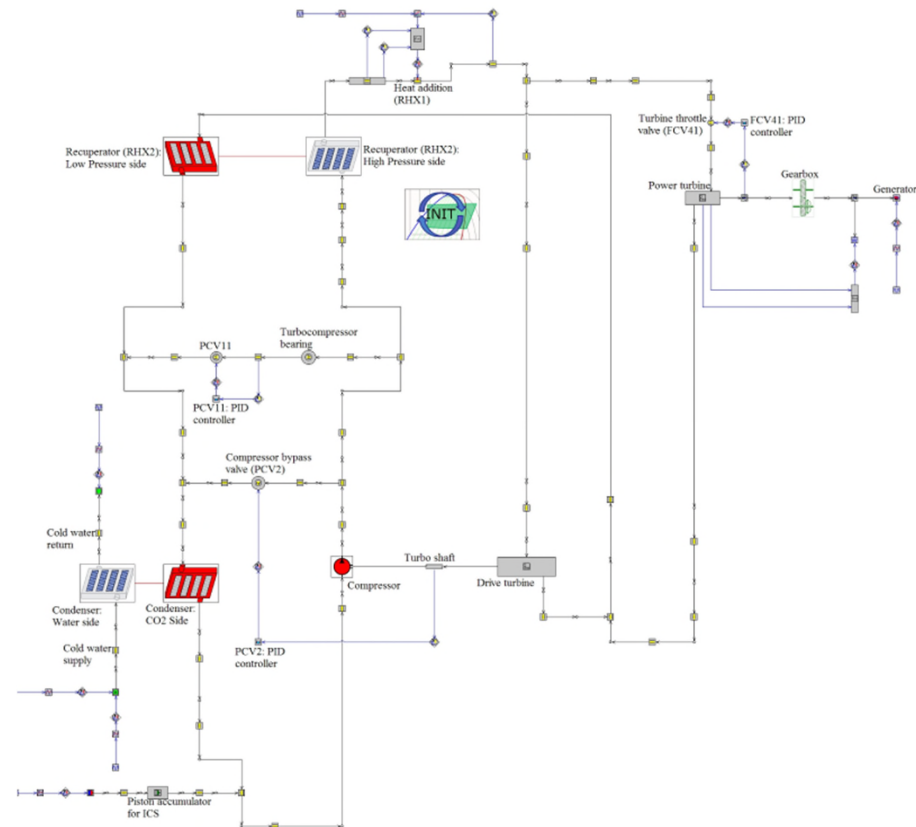



Transient modeling tools – not an exhaustive list!

- Commercial codes
 - Aspen, NPSS, Flownex, Modelon, GT-SUITE, AME-Sim, TRNSYS, MATLAB-Simulink, Dymola
- Open-source codes
 - Modelica (language, not a program)

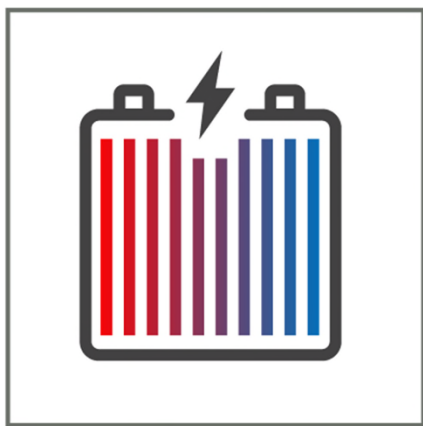

Q&A

8th sCO₂ Symposium

San Antonio, TX February 26-29, 2024

Cycles Tutorial

Owen Pryor, SwRI

Tim Held, Echogen Power Systems

What is a cycle?

Cycles use thermodynamic processes to overcome the second law of Thermodynamics

First Law of Thermodynamics: Conservation of energy

$$\underbrace{\text{Energy in} - \text{Energy out}} = \underbrace{\Delta \text{System Energy}}$$

Energy transfer in terms of heat, work, mass

$$E_{\text{in}} - E_{\text{out}} = (Q_{\text{in}} - Q_{\text{out}}) + (W_{\text{in}} - W_{\text{out}}) + (E_{\text{mass,in}} - E_{\text{mass,out}})$$

Internal, potential, kinetic, etc.

$$\Delta E_{\text{system}} = m(u_2 - u_1) + \frac{1}{2}m(V_2^2 - V_1^2) + mg(z_2 - z_1)$$

Second Law of Thermodynamics: Energy has quality

Natural processes occur in the direction of decreasing entropy

Two basic types of cycles run the world

Make things hot or cold
At the cost of work

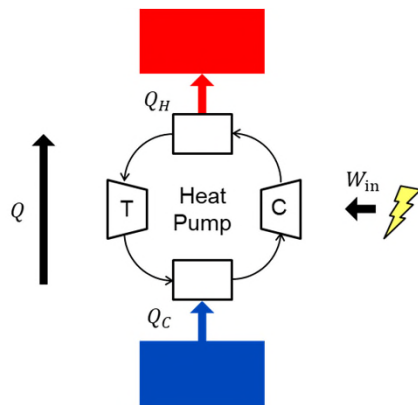

Heat Pump / Refrigeration Cycles

Increase pressure, potential, power
At the cost of heat

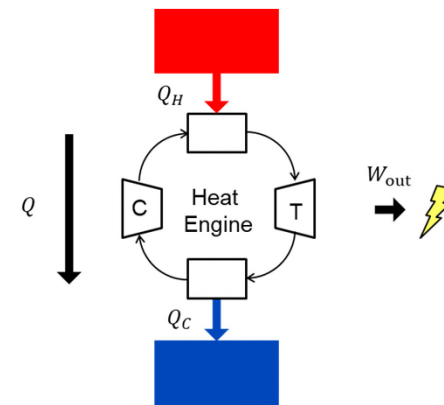

Heat Engine / Power Cycles

Motivation for CO₂ as a Working Fluid

High Efficiency

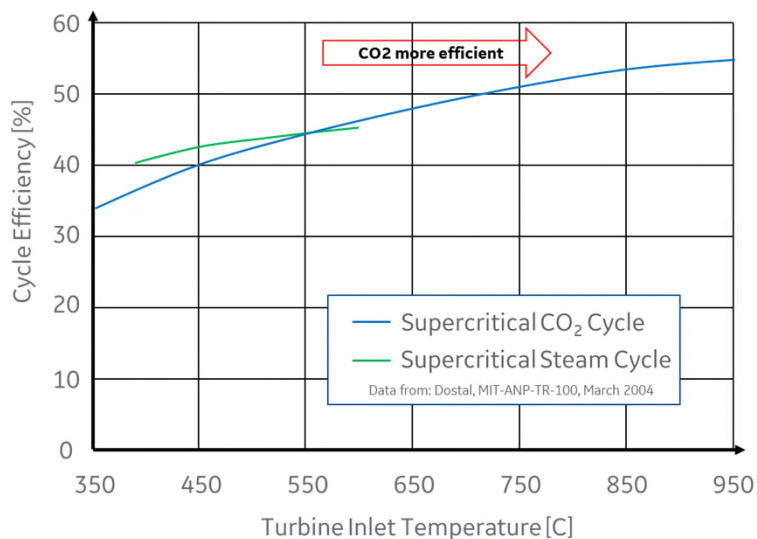

Smaller Turbomachinery

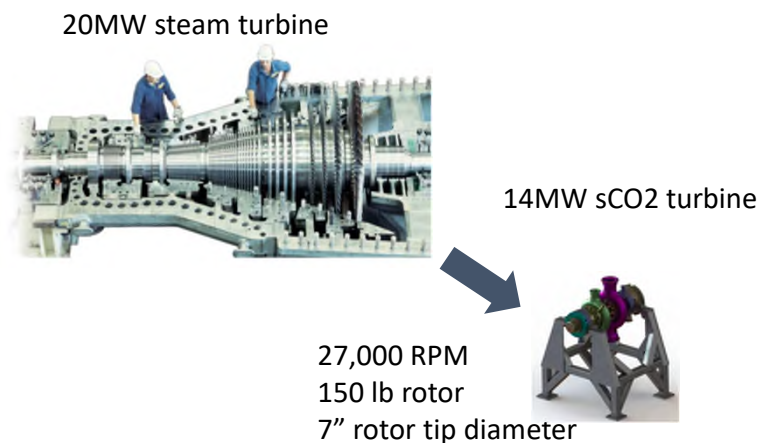

Renewed interest due to enabling advances in:

- Materials (USC, AUSC programs)
- Dry Gas Seals (more experience in CO₂ and LNG compressors)
- Compact Heat Exchangers

Work on sCO2 predates Dostal



Feher 1967

1. Feher, E. G., "The Supercritical Thermodynamic Power Cycle," Douglas Paper No. 4348, presented to the Intersociety Energy Conversion Engineering Conference, Miami Beach, Florida 13-17 Aug. 1967.

AFAPL-TR-68-100

INVESTIGATION OF SUPERCRITICAL (FEHER) CYCLE

E. G. Feher et al.

Astropower Laboratory, Missile & Space Systems Division
A Division of McDonnell Douglas Corporation

TECHNICAL REPORT AFAPL-TR-68-100

October 1968

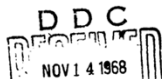

Angelino 1968

Carbon Dioxide Condensation Cycles For Power Production

G. ANGELINO
Lecturer of Special Power Plants,
Politecnico, Milan, Italy

The thermodynamic performance of several condensation cycles employing carbon dioxide as working medium is analyzed and discussed. A balanced distribution of thermodynamic losses between mechanical components and heat exchangers obtained through a compression performed partially in the liquid and partially in the gas phase yields cycle efficiencies which are among the highest achievable in present-day energy systems. At turbine inlet temperatures higher than 550 deg C single heating CO₂ cycles exhibit a better efficiency than reheat steam cycles. This may have of particular interest in connection with high temperature nuclear heat sources. However, the requirement of low temperature cooling water for a good cycle arrangement represents a geographical limitation to the widespread application of CO₂ condensation cycles.

Introduction

Large capacity steam power stations represent the most efficient tool for the conversion of heat into mechanical energy. After a rapid improvement of cycle configuration and equipment during the last two decades, steam plants reveal at present some thermodynamic and technological limitations which may be a hindrance to further developments. These limitations can be summarized as follows: (a) Cycle economy is not very sensitive to the rise of the turbine inlet temperature beyond about 600 deg C; (b) cycle complexity increases with the plant capacity due to the necessity of providing additional feed-water heating flow and additional low pressure turbine sections for units of growing output.

Stations employing the closed-cycle gas turbine are characterized by a simpler arrangement of the components and by the ability to take full advantage of increasing maximum temperatures. However, their efficiency, even for the highest practical temperatures, is considerably lower than that of current steam stations.

Condensing or partially condensing cycles employing carbon dioxide as a working medium allow the achievement of efficiencies similar to that of steam cycles, or even better for the highest tur-

Contributed by the Gas Turbine Division and presented at the Gas Turbine Conference, Washington, D. C., March 17-21, 1968, of THE AMERICAN SOCIETY OF MECHANICAL ENGINEERS. Manuscript received at ASME Headquarters, December 26, 1967. Paper No. 68-GT-33.

bine inlet temperatures. The cycle arrangement retains almost the same simplicity as the gas turbine configurations. However, due to the low critical temperature of carbon dioxide, condensing cycles are obtainable only in countries where cooling water at temperatures not higher than 12-15 deg C is available the year round.

Deep water temperature of the largest European or North American Lakes is about 4 deg C at all the times of the year. A similar temperature characterizes deep waters of the open sea (while the temperature of the Mediterranean, at the depth of 500 m, has the constant value of about 13 deg C). Along the northern coasts of the Eurasian and of the American continents, seawater at about 6 deg C is available during almost the whole year. In these regions the use of carbon dioxide as working medium is particularly attractive both from a thermodynamic point of view (full advantage can be taken of the low temperature of the cold source) and for technological reasons (there is no danger of solidification of the working fluid during shutdown periods).

The requirement of abundant, low temperature water for cooling purposes entails a geographical limitation to the application of carbon dioxide condensing cycles. Hydraulic works larger than required by steam stations could be economy; however, their influence on the overall station economy should not be predominant.

Cycle Configurations

For carbon dioxide cycles, as for steam, a variety of cycle

Nomenclature

A, B, C, D = conventional denotation of cycles, Fig. 1
 a = velocity of sound, m/sec
 c_p = specific heat at constant pressure, kcal/kg-deg C
 c_v = specific heat at constant volume, kcal/kg-deg C
 k = adiabaticity, kcal/kg
 l = specific work, kcal/kg
 l_p = high pressure turbine work in cycle C, kcal/kg
 p = pressure, atm
 Q_1 = primary heat, kcal/kg
 Q_2 = waste heat, kcal/kg
 S = entropy, kcal/kg-deg C
 T = temperature, deg C
 σ = condensed fraction of work

Δh = regenerative heat, kcal/kg
 $\Delta h_1/\Delta h_2$ = heat transfer parameter, proportional to heat exchange surface, deg C⁻¹
 Δt_1 = minimum temperature difference in low temperature regenerator, deg C
 Δt_2 = minimum temperature difference in high temperature regenerator, deg C
 Δt_3 = being also the maximum temperature difference in low temperature regenerator
 $\Delta p/p$ = fractional pressure loss of cycle
 ΔS = entropy production, kcal/

ing medium
 Δt_{12} = log mean temperature difference, deg C
 Δt_{23} = log mean temperature difference, deg C
 η = heat efficiency
 η = efficiency
 ρ = density, kg/m³
Symbols
 1 = low temperature regenerator
 2 = high temperature regenerator
 ϵ = exchanger or Carnot cycle
 max = maximum
 min = minimum
 m = mass
 p = pump
 s = saturation or condensation
 t = turbine
 w = useful work

Journal of Engineering for Power

Copyright © 1968 by ASME

JULY 1968 / 287

Dostal 2004



High Efficiency

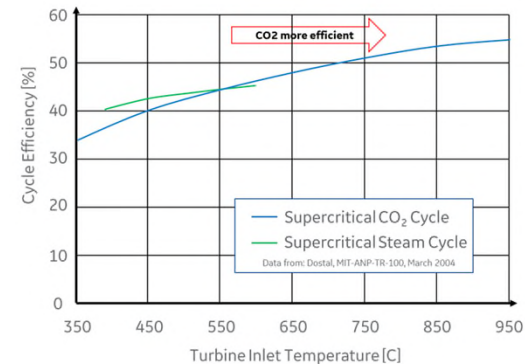

AD 843063

sCO₂ Application Space

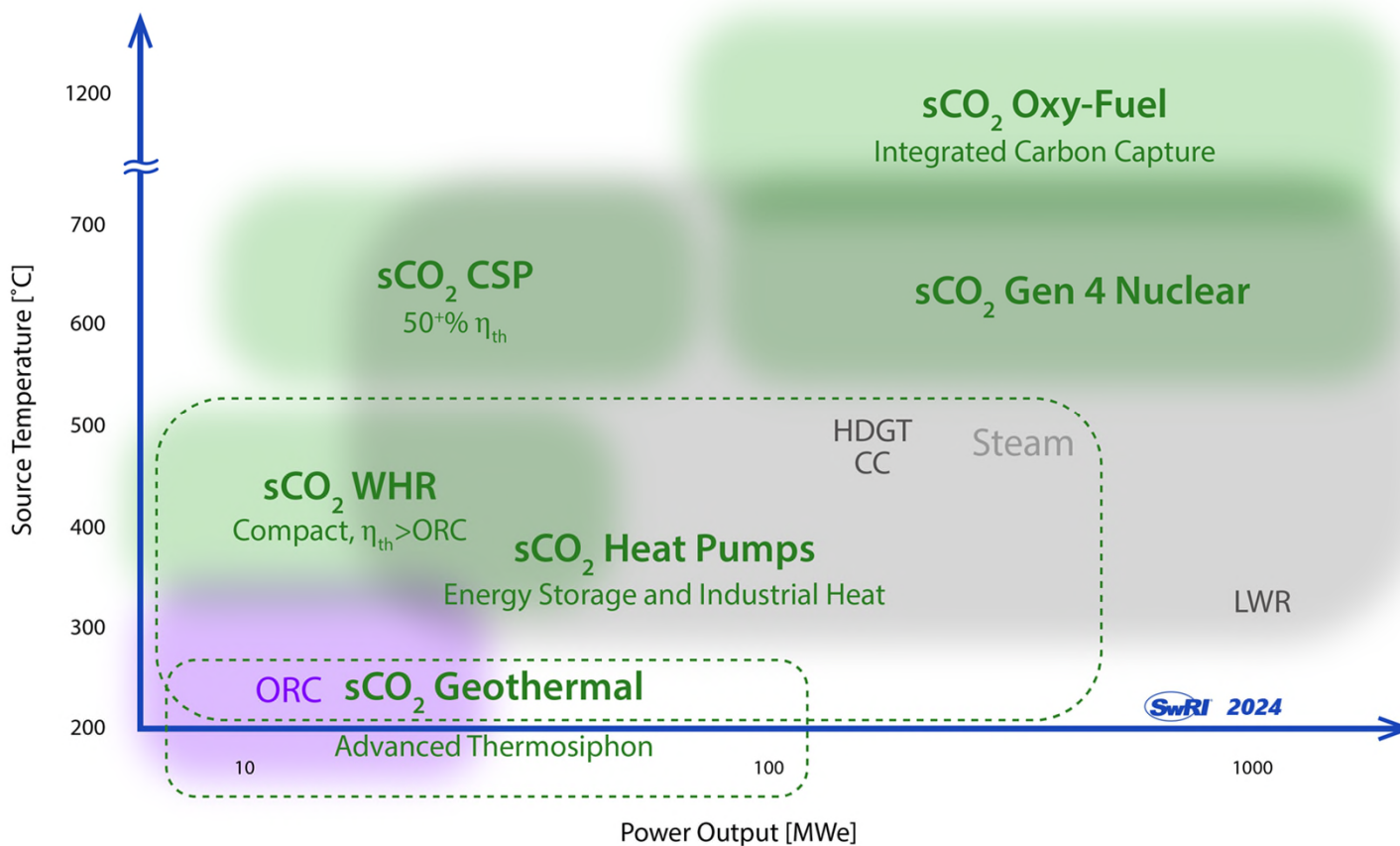

Simple Recuperated sCO₂ Brayton Cycle

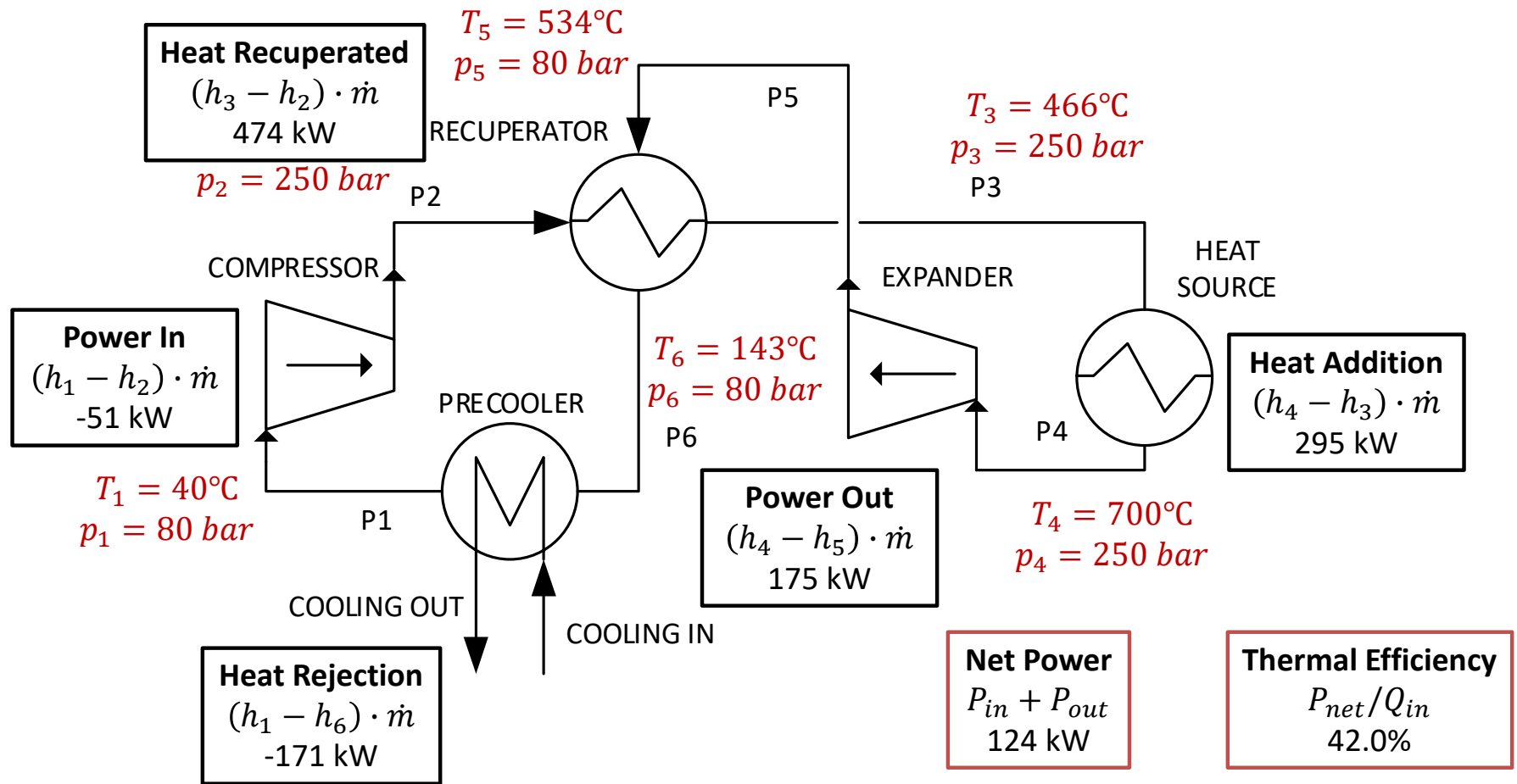

Basic Components in a Simple Recuperated Cycle

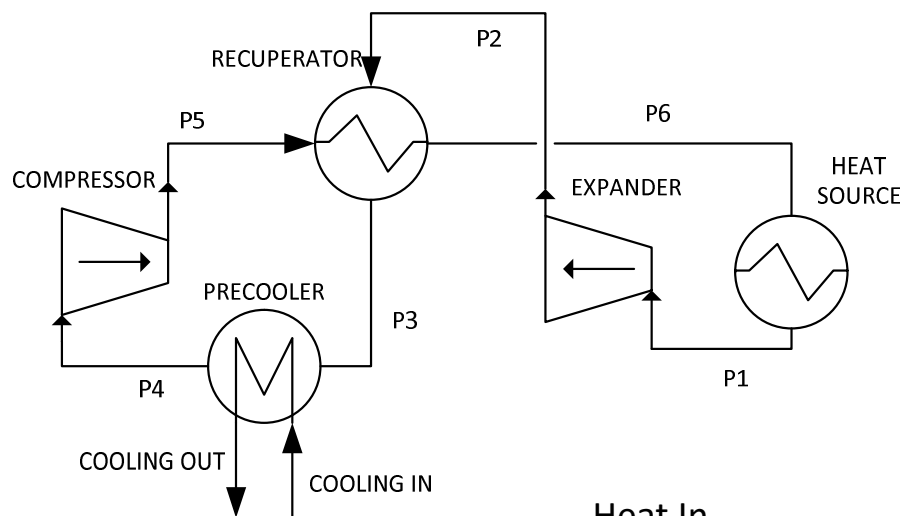

Heat In
Heat Out
Compress
Expand
Recuperate

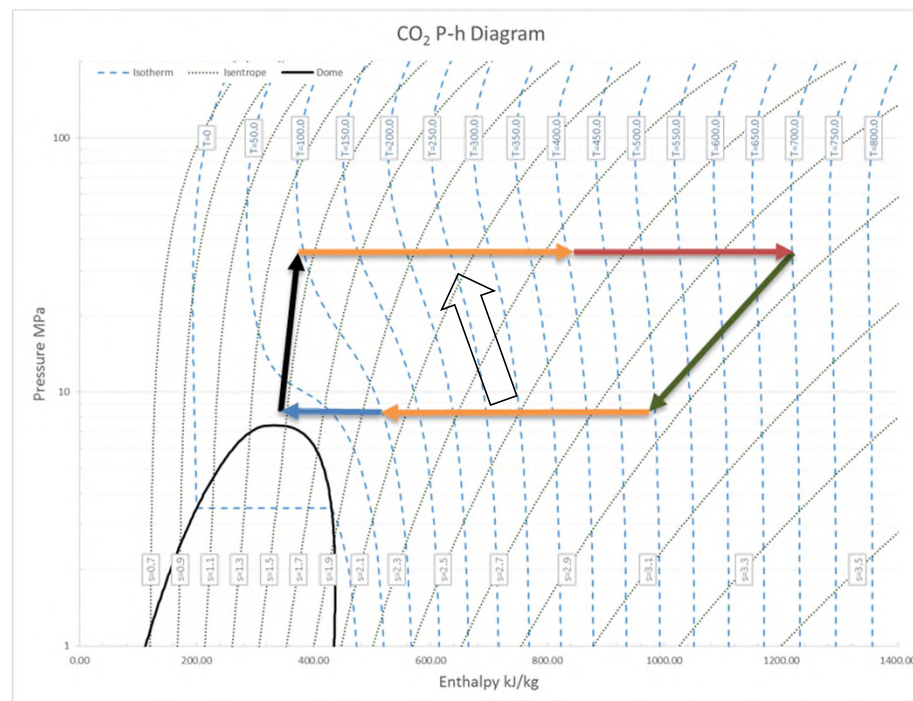

What's Special about CO₂?

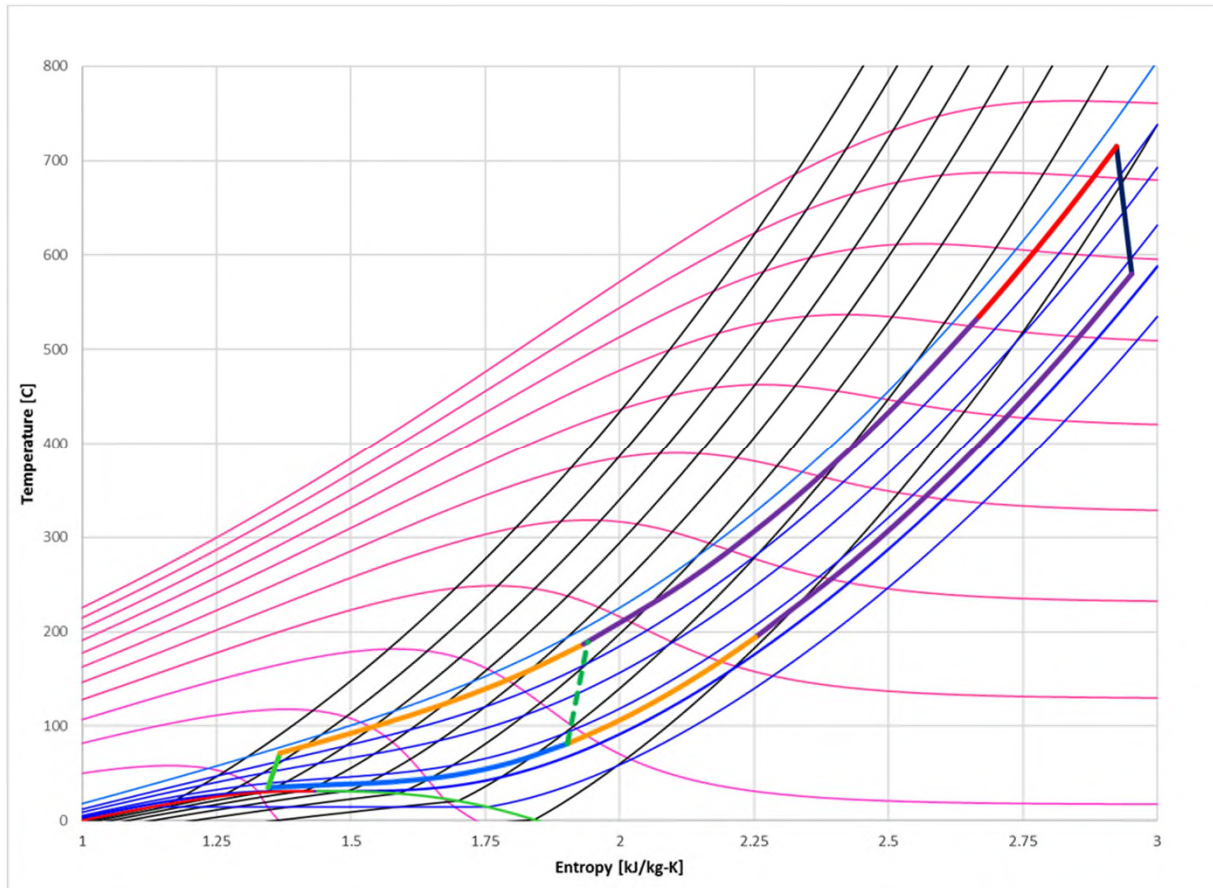

T-s Diagram for CO₂ with typical high temperature recompression cycle

Note ambient temperature is near the critical point

Pink lines are constant enthalpy – horizontal indicates $h=C_p \cdot T$ is valid

What's Special about CO₂?

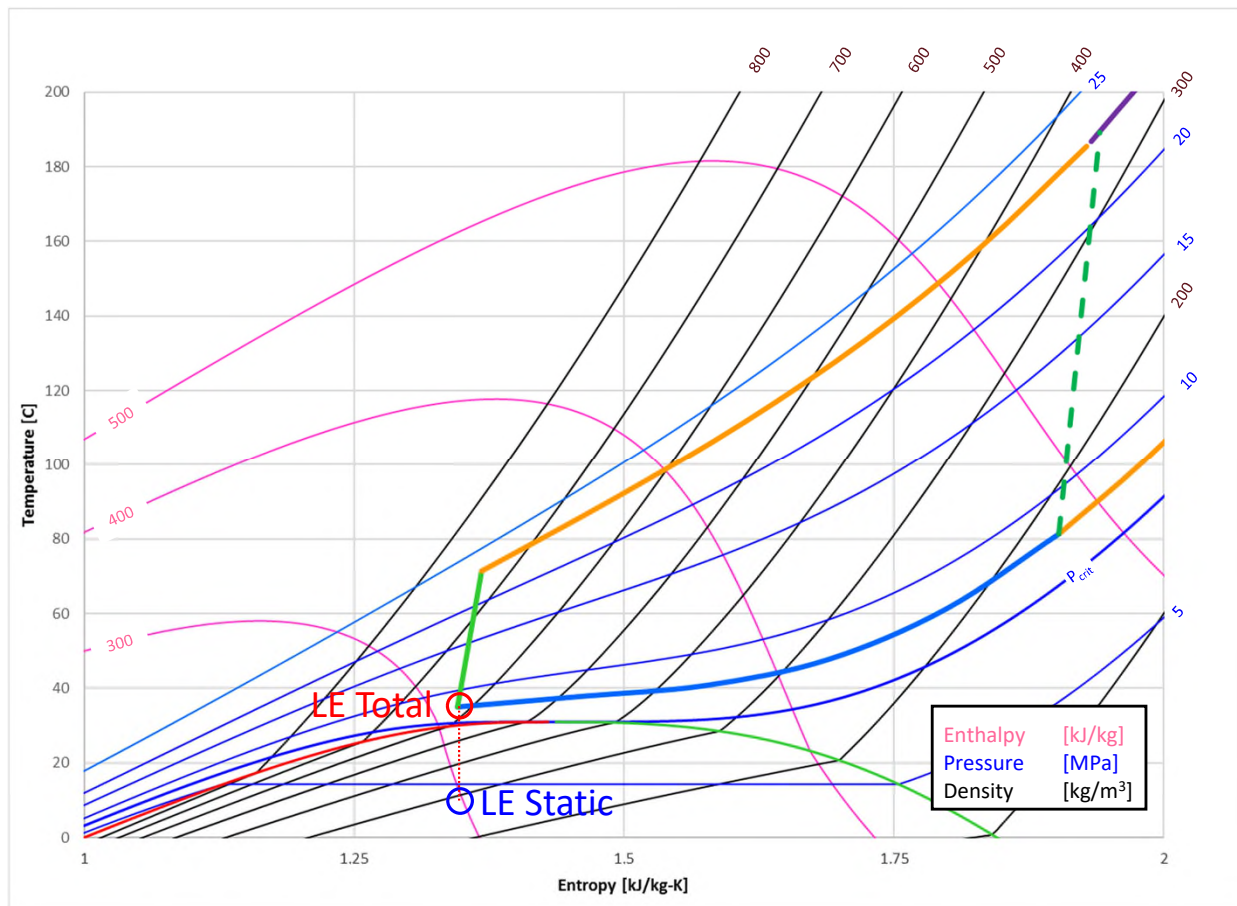

Close up of low T region

Constant enthalpy lines far from horizontal



Quiz

- ★ Statepoint 1 is at 82.4 bara and 34.2 C
- ★ Statepoint 2 is at 75.0 bara and 32.0 C

Which has a higher enthalpy?

Quiz

- ★ Statepoint 1 is at 82.4 bara and 34.2 C
- ★ Statepoint 2 is at 75.0 bara and 32.0 C

Which has a higher enthalpy?

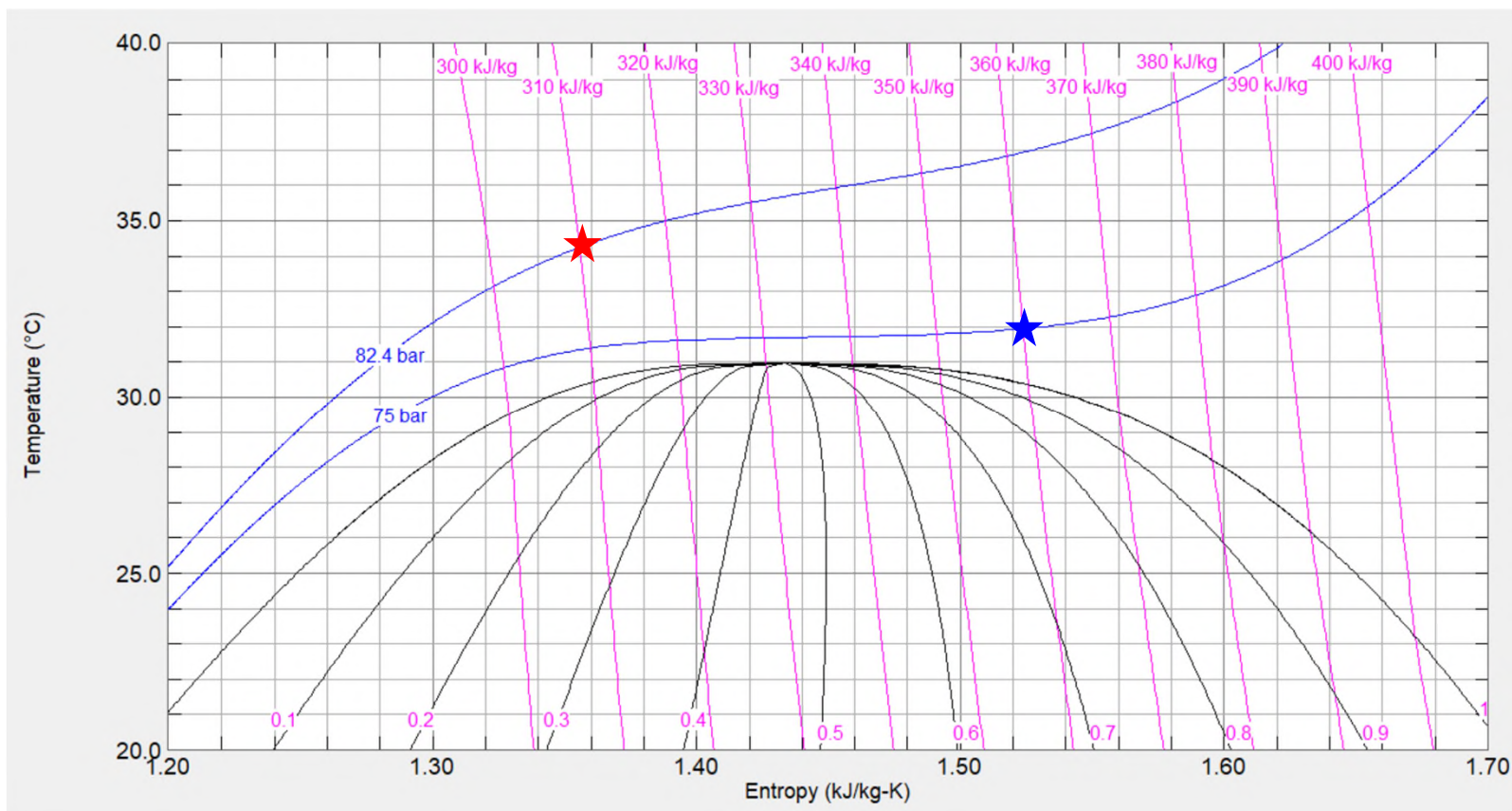

Common CO₂ Equations of State

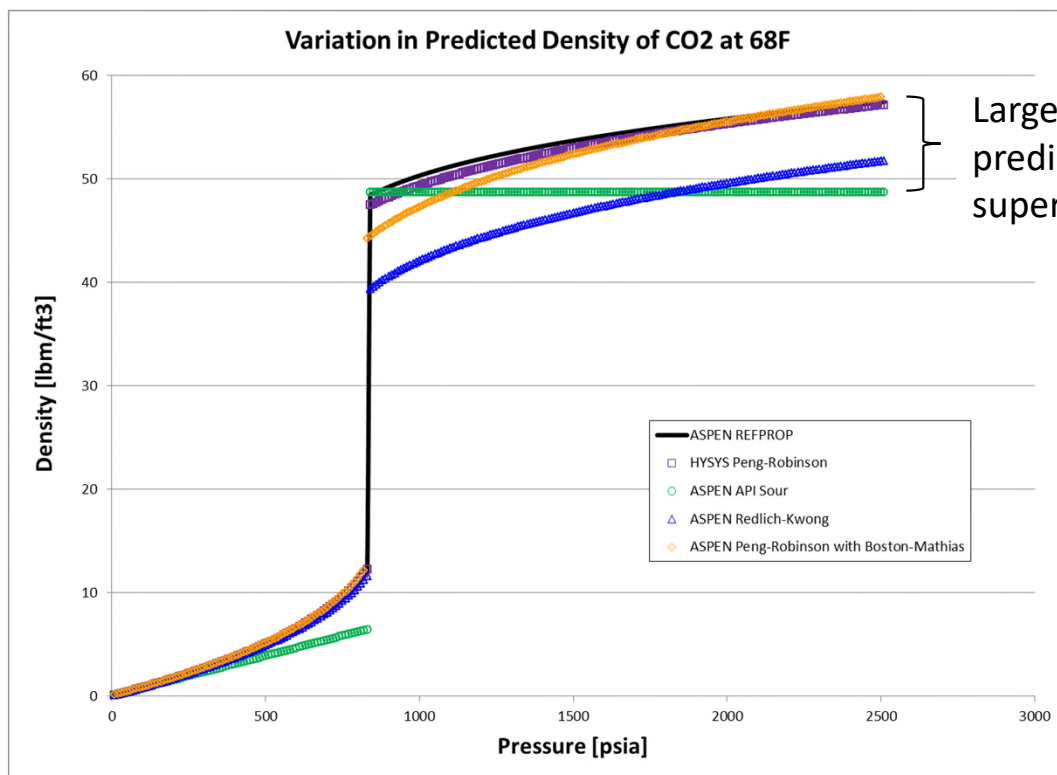

Large variation in predicted density for supercritical CO₂

Important to use Refprop to ensure accuracy of EOS

The sCO₂ Community has created many types of cycles

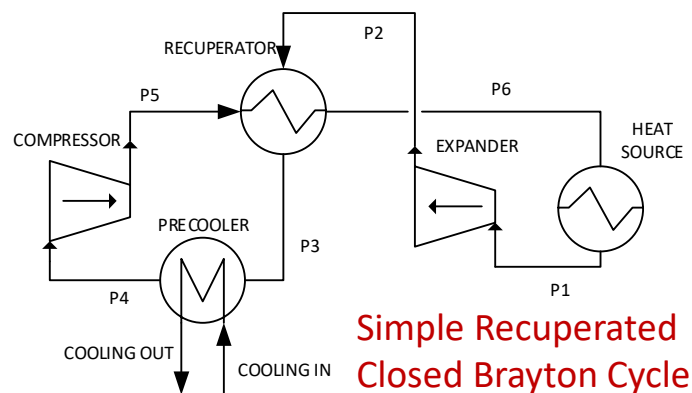

Simple Recuperated Closed Brayton Cycle

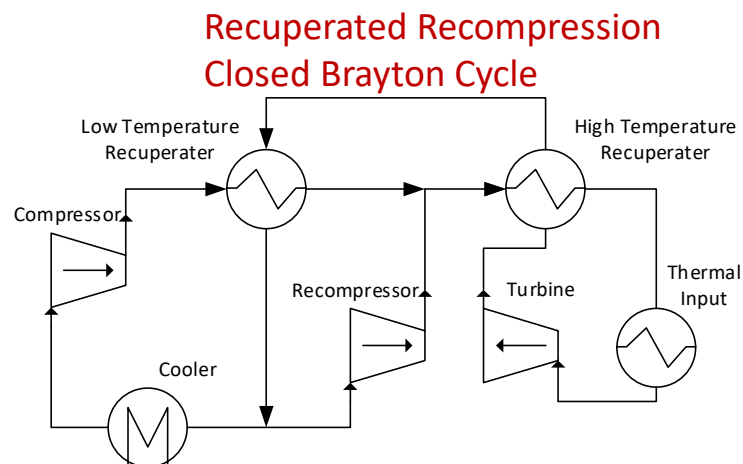

Recuperated Recompression Closed Brayton Cycle

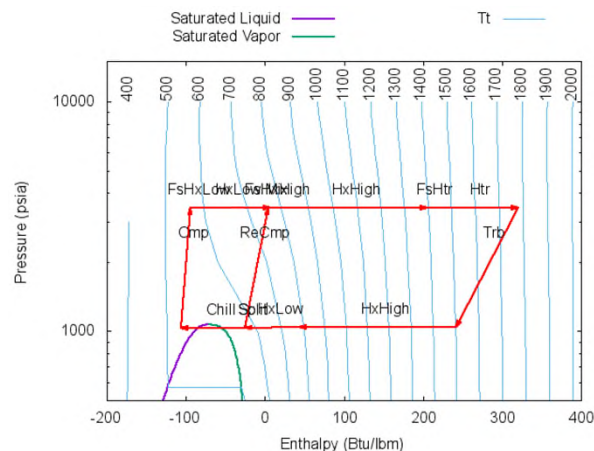
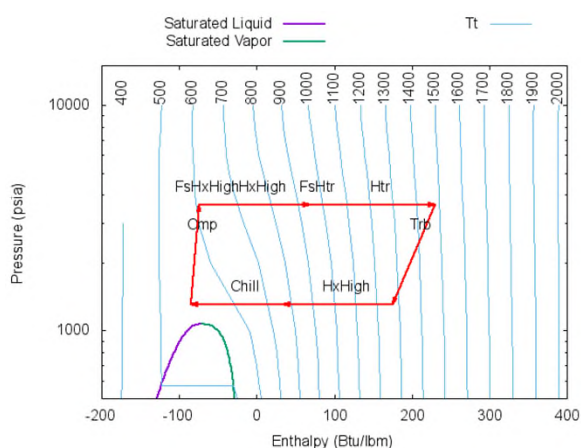



Applications and Architectures

High Temperature Cycles



sCO₂ Recompression Cycle

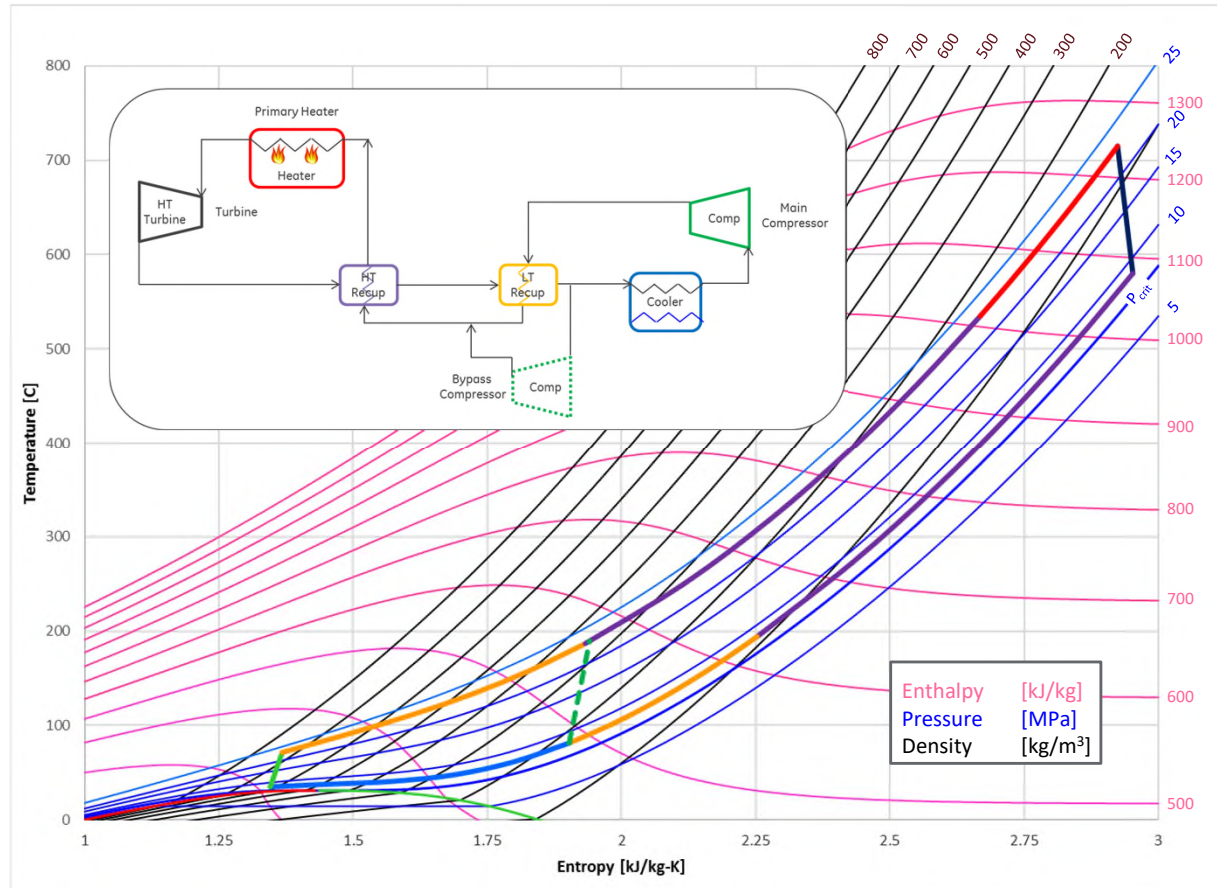

High Temperature Cycles – Thermodynamic Benefit

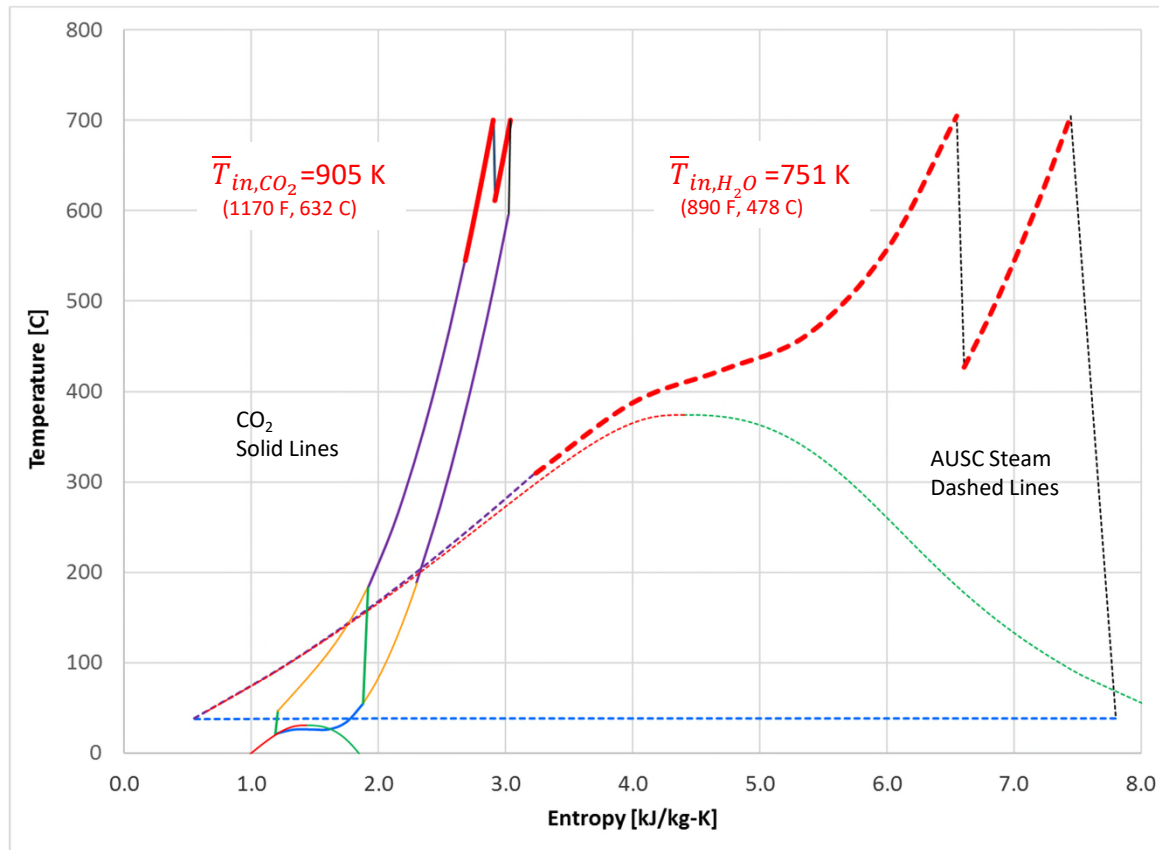

150 C increase in average heat addition temperature
 → 6.8 pts in Carnot efficiency

High Temperature Cycles – Flow Differences

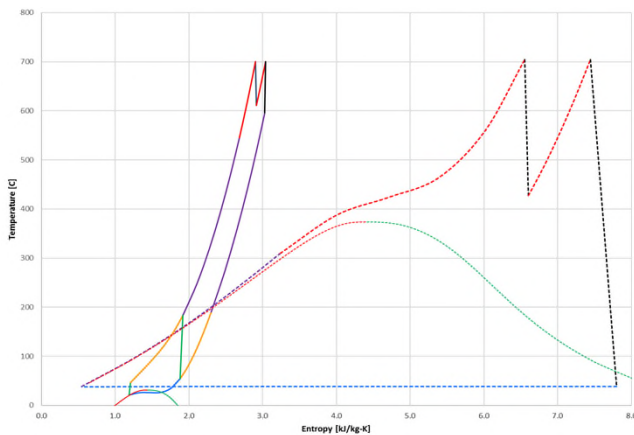

Specific Heat Input

CO₂ = 307 kJ/kg

H₂O = 3040 kJ/kg

CO₂ mass circulation ~10X H₂O

CO₂ HP Inlet Volume Flow ~12X H₂O

CO₂ IP Inlet Volume Flow ~4.6X H₂O



CO₂ Requires Larger Pipes for Hot Flows

CO₂ Turbine Exit Vol Flow ~0.03X H₂O → CO₂ Turbines much smaller

Waste Heat Recovery



Waste Heat Recovery – Thermodynamic Benefit

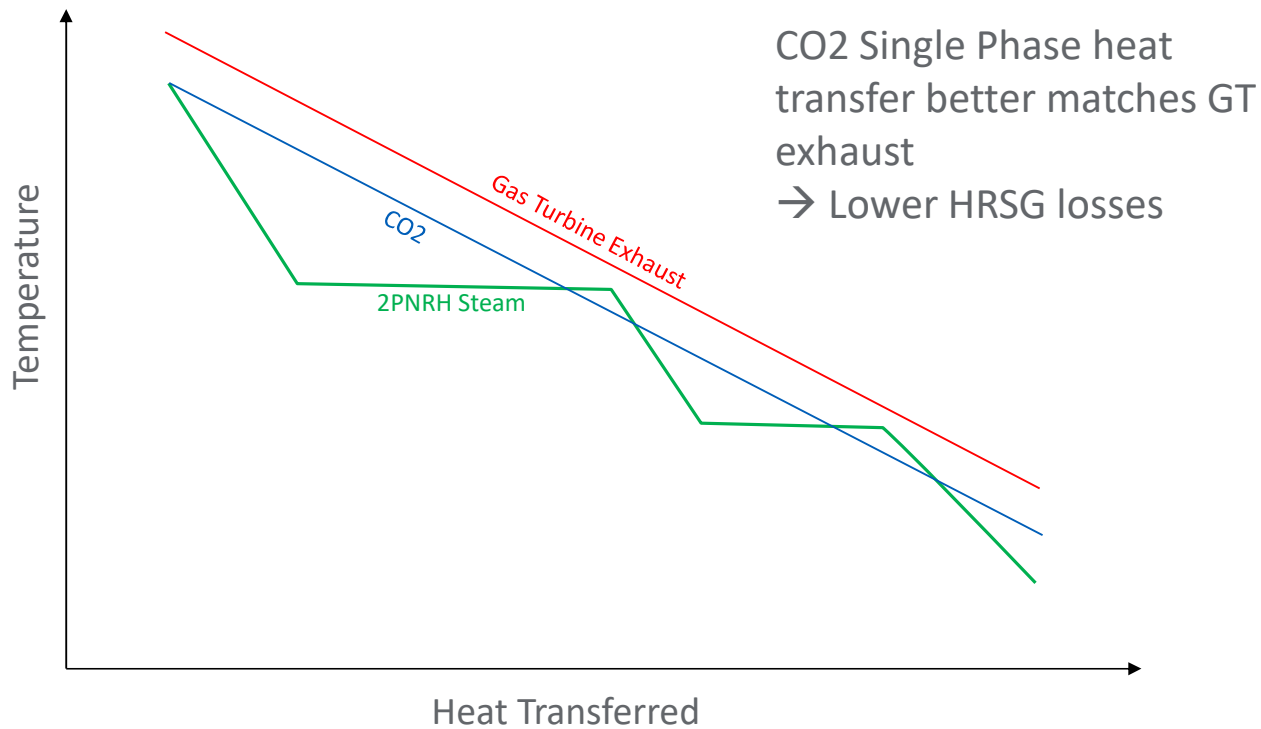

Fundamentally different benefit vs High Temperature cycles

Cascaded CO₂ Bottoming Cycle

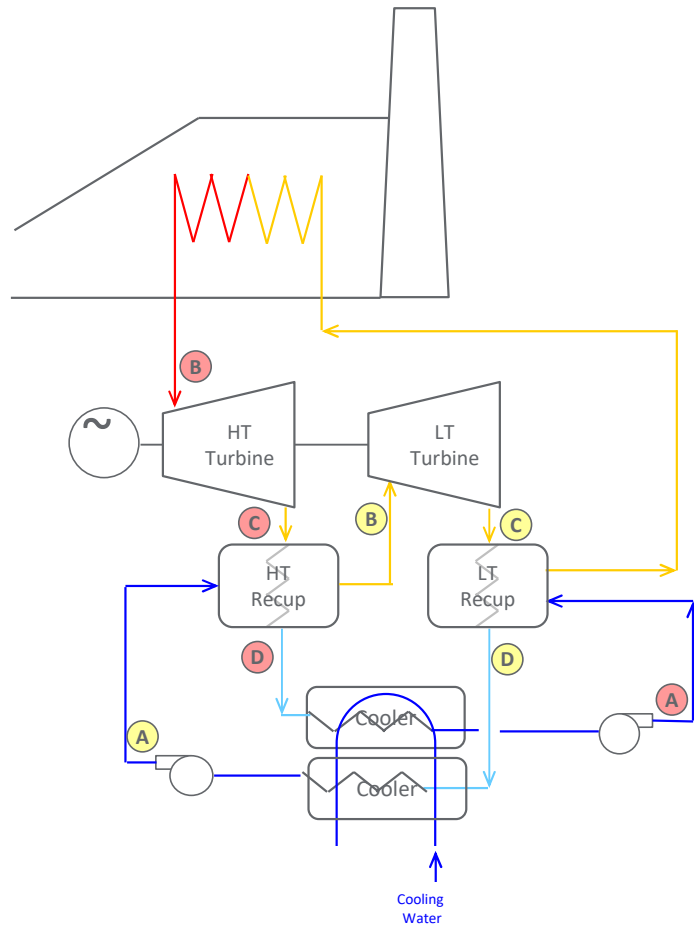

Cascaded cycle uses two sCO₂ loops to maximize performance

CO₂ circulates in two closed loop cycles – only small make-up for shaft seal leakages

Small equipment size enables BC to approach aeroderivative transient performance

Impact of Ambient Temperature

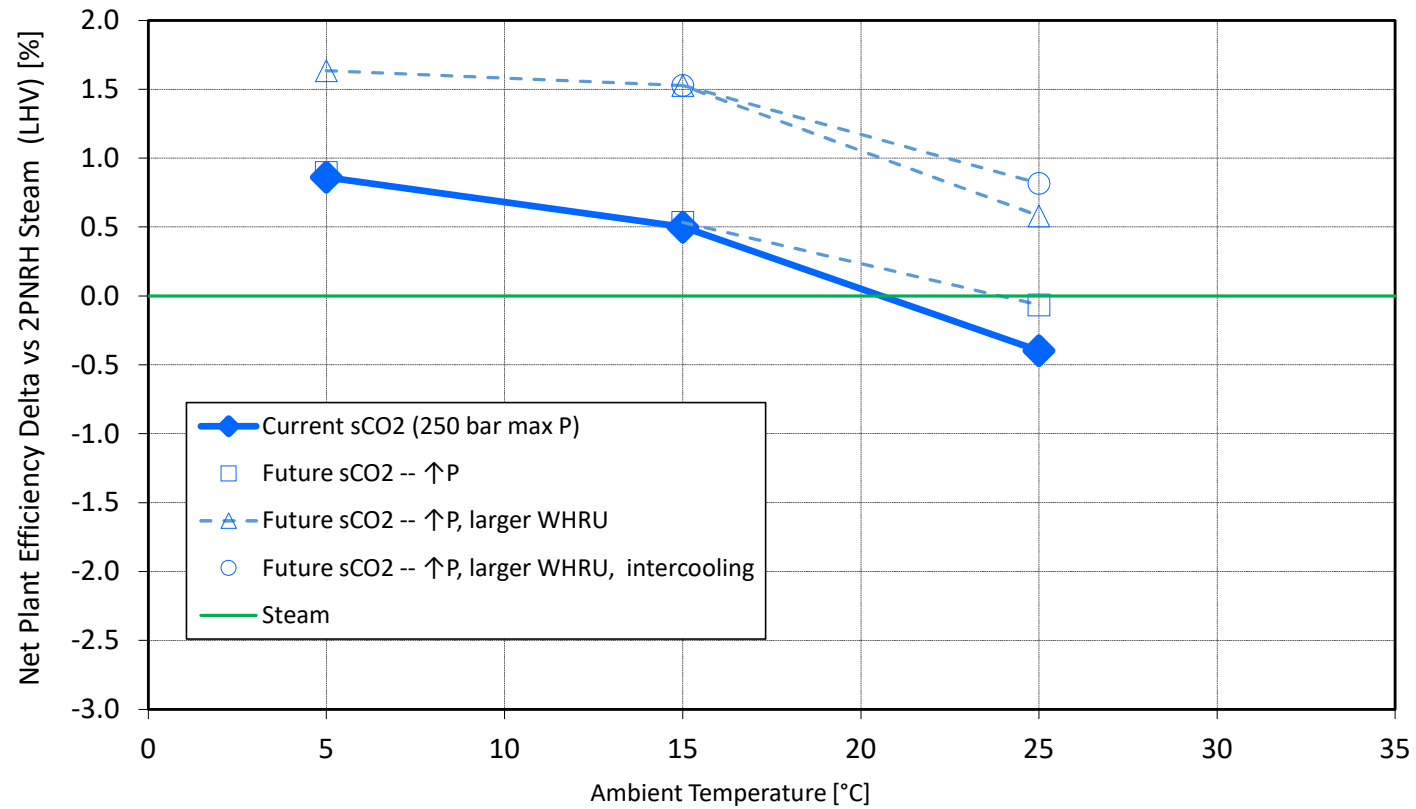

GE data : P. Huck, M. Lehar, "Performance comparison of a supercritical CO2 versus steam bottoming cycles for aeroderivative gas turbines at various ambient temperature," ChemIndix, Nov 2016, Manama, Bahrain

Condensing Cycles

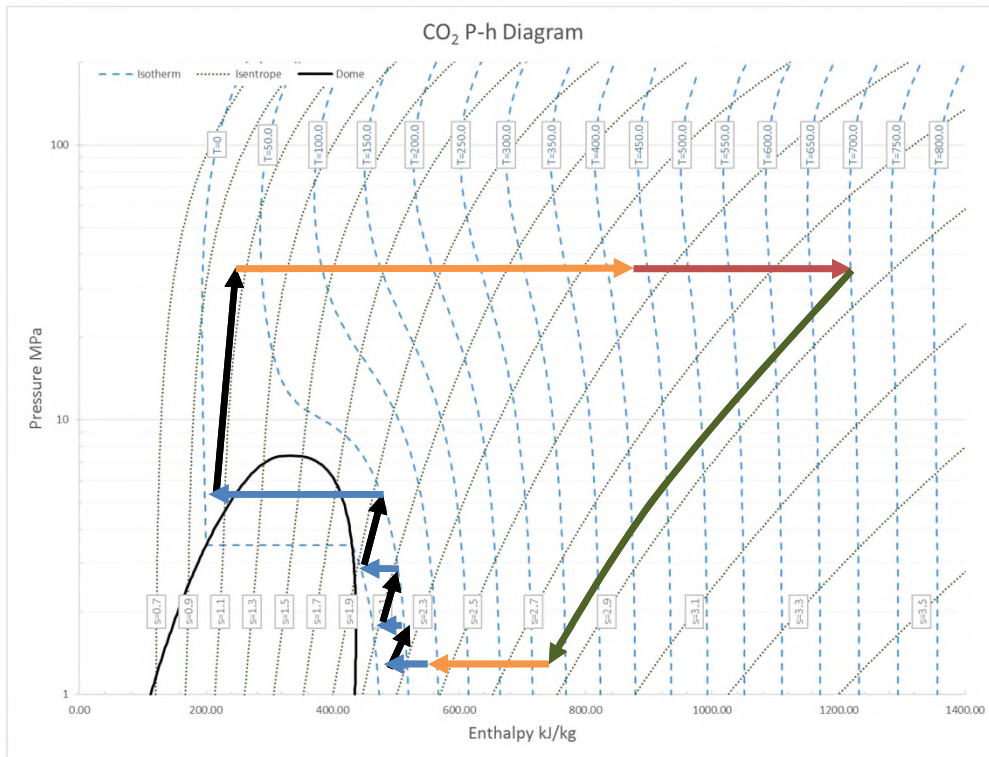

- Transcritical cycle
- Utilizes partial compression, condensation, and pumping to minimize compression work
- Must balance refrigeration / cooling requirements against compression requirements
- Can achieve efficiencies close to recompression cycle

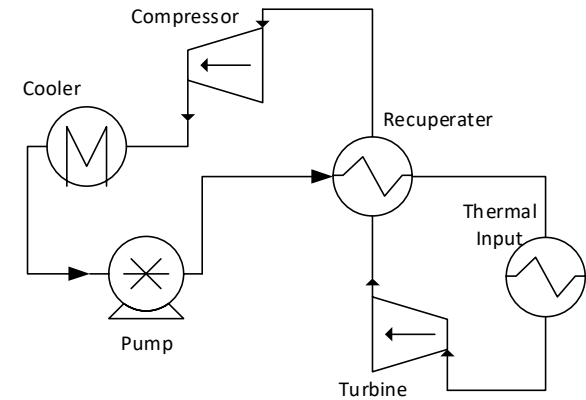

Allam (Direct Oxy-Fuel) Cycles

- Direct fire oxy-fuel combustion changes the cycle to a semi-open cycle
- Mass balance issues
- CO₂ + combustion products
- Clean up and water removal

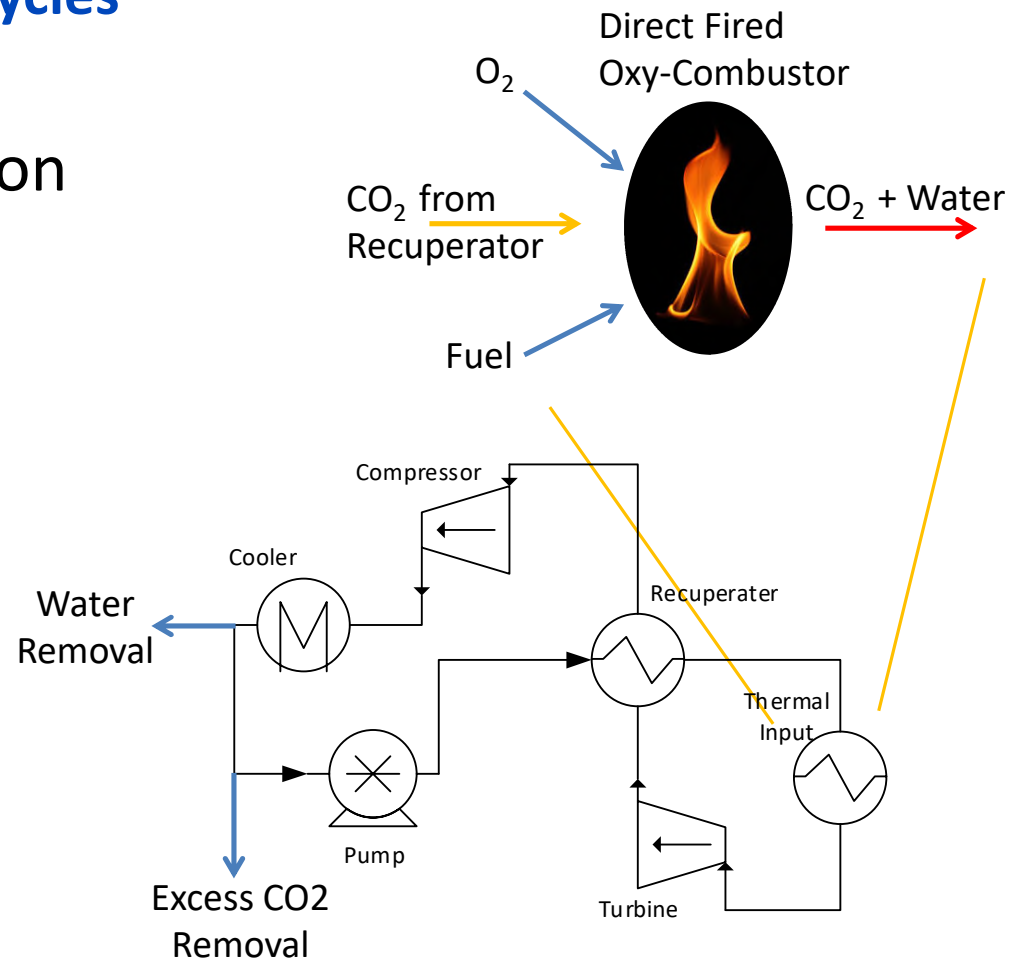

sCO₂ Heat Pumps for Industrial Heat and ETES

