



SAGE GEOSYSTEMS

Feasibility of Interstage Cooling for a Geothermal sCO₂ Power Plant

Owen M. Pryor, Ph.D.¹, Reese Roddy¹, Lev Ring, Ph.D.², Doug Simpkins², Victoria McGuire²

¹Southwest Research Institute

²Sage Geosystems

2026 International sCO₂ Energy Technologies Symposium

March 3, 2026

Pittsburgh, PA



SAGE GEOSYSTEMS

©SOUTHWEST RESEARCH INSTITUTE

MECHANICAL ENGINEERING

swri.org

1

Outline

Background & Motivation

- Who is Sage?
- Why sCO₂ for Geothermal?
- Advantages of Interstage cooling

Cycle Modeling

- Model
- Model Assumptions

Results

Future Work and Conclusions



APPLIED

Background & Motivation



©SOUTHWEST RESEARCH INSTITUTE

MECHANICAL ENGINEERING

swri.org

Sage Geosystems aims to leverage geothermal to provide clean power around the world

2021-2025

Energy Storage

- 2MW-4MW per well
- 65-70% round-trip efficiency (RTE)
- Duration discharge of 8-24 hours

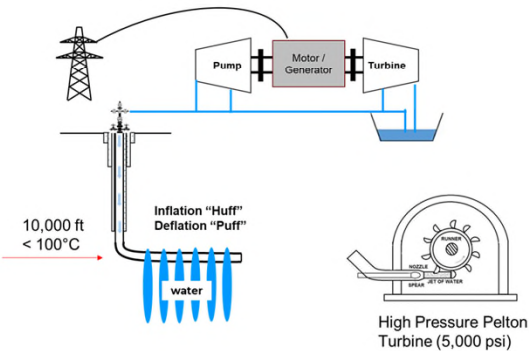

2022-2027

Power Generation (Pressure Geothermal)

- 3-5 MW net output per 2-well pair

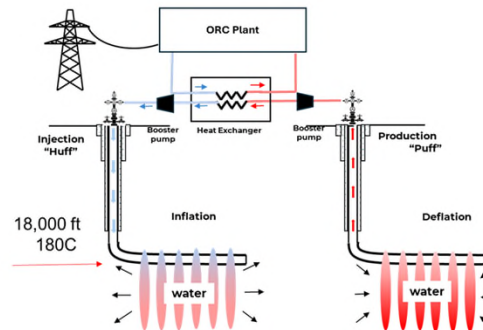

200°C LCOE: \$65-\$75/MWh

2026-2030

Drill Shallow, Frac Deep (Superhot Geothermal)

- 25-35 MW net output

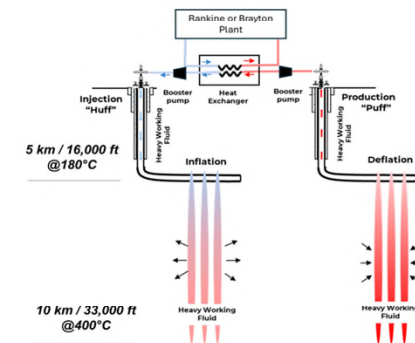

350°C LCOE: \$35-\$45/MWh

Significant advantages to sCO₂ as temperature increases

Physics tells us: 10X increase in power generation potential per well from 150°C to 350°C (at constant flow rate), assuming standard binary cycle power plants

Relationship between temperature and net power is not linear

- 2.5X in temperature results in 10X increase in net power across multiple thermodynamic cycles
- Net output is one of the most significant factors in geothermal economics (LCOE)

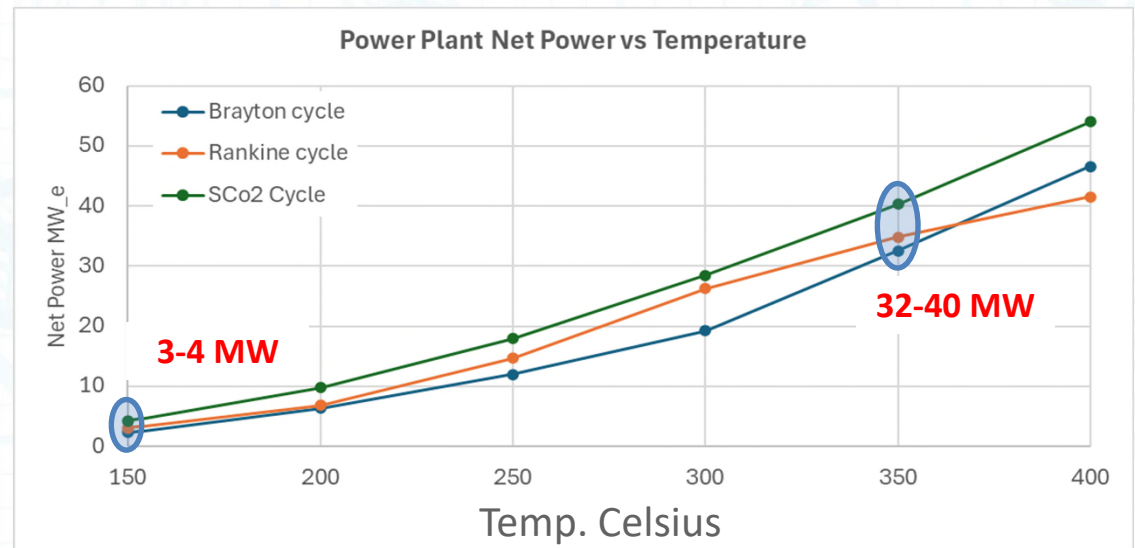

Interstage Cooling allows for a significant reduction in compression power

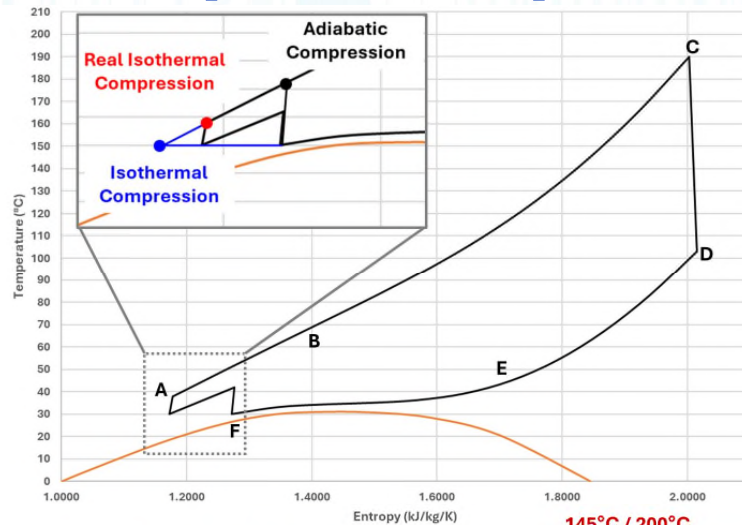

The Challenge:

- Compressions consumes significant power in sCO₂ cycles
- CO₂ temperature rises during compression
- Increased work required as temperature increases

The Solution: Interstage Cooling:

- Maintain constant temperature during compression
- Cool CO₂ between compression stages (30-55°)

Performance Benefits:

- 1 intercooling stage: ~5% net power increase
- 2 intercooling stage: ~9% net power increase
- Minimal capital cost increase

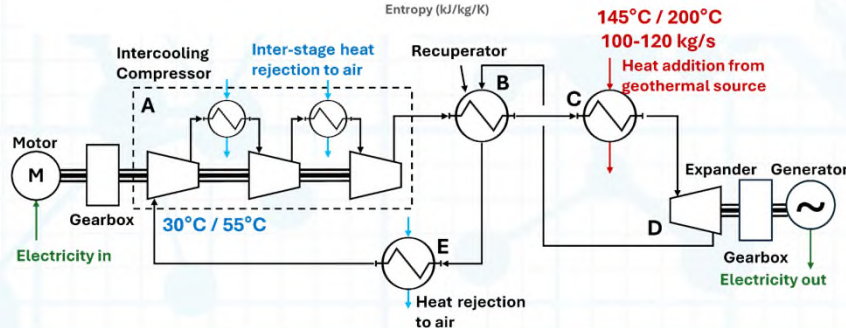

Cycle Model



SwRI and Sage built a cycle model to answer several questions

1-3 stages of compression

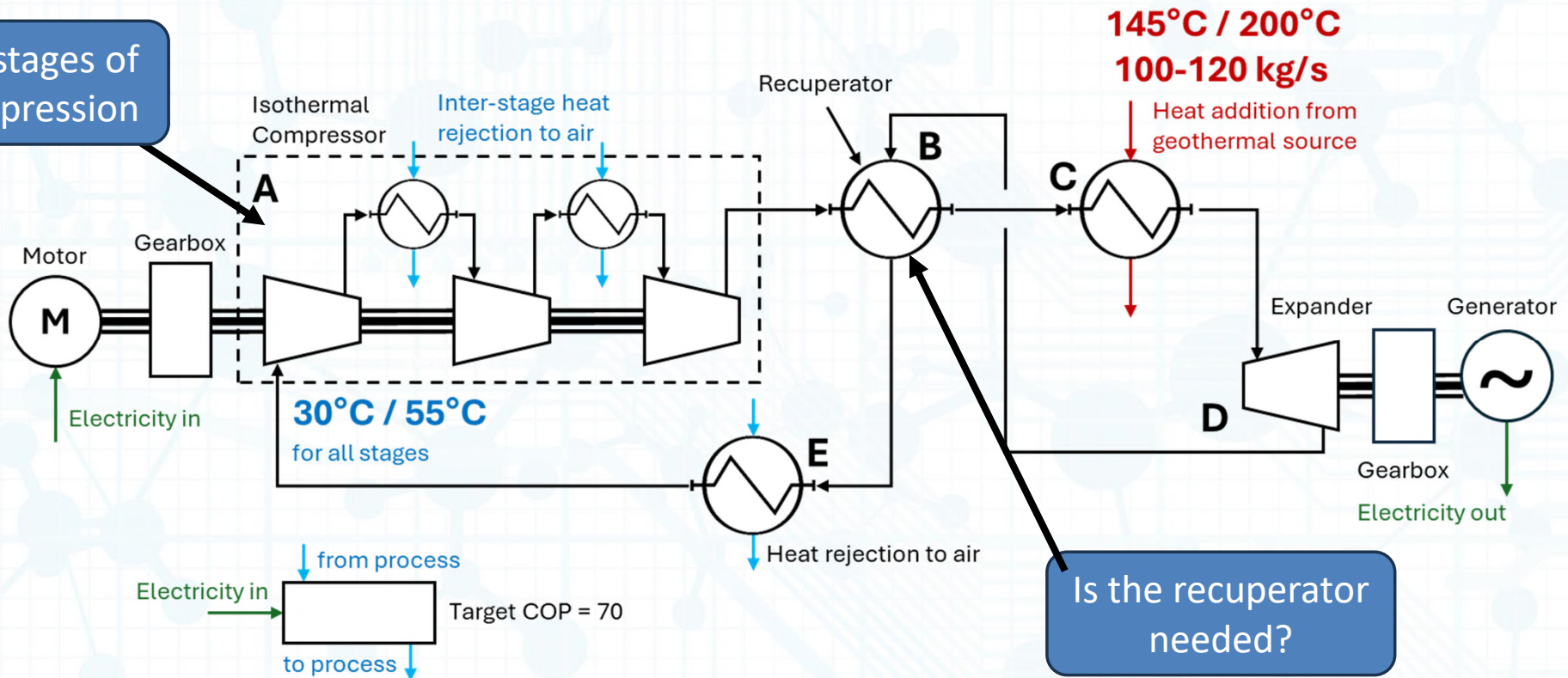

SwRI and Sage built a cycle model to answer several questions

How would ambient affect the performance?

Impact of heat source temperature

What is the impact on cycle performance?

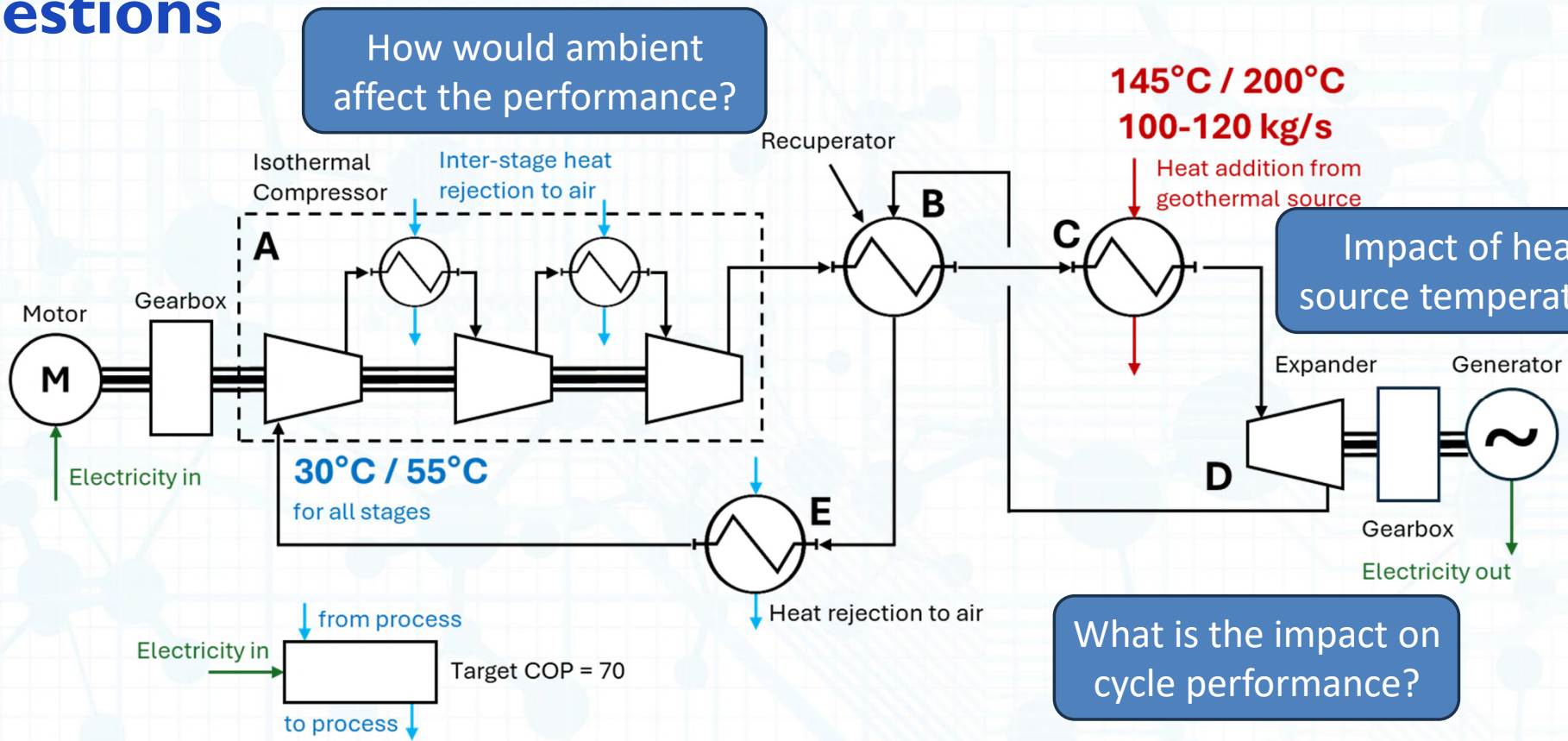

Key Model Assumptions

Key Assumptions

- Motor efficiency – 95%
- Generator efficiency – 95%
- Gearbox efficiency – 98%
- Turbine (isentropic) efficiency – 92%
- Compressor (isentropic) efficiency per stage – 84%
- Primary heat exchanger pinch point – 10°C
- Recuperator pinch point – 5°C
- Process cooling heat exchanger pinch point – 5°C

Loop Set Points

- Brine Inlet Temperature: 200 °C
- Brine Flow Rate: 100 kg/sec
- Compressor Inlet Pressure: 80 bar
- Compressor Inlet Temperature: 30 °C

Cycle Performance Sweep

- CO2 Flow Rate: 100 – 250 kg/sec
- Turbine Inlet Pressure: 150 – 280 bar

Vary number of stages: 1, 2, 3

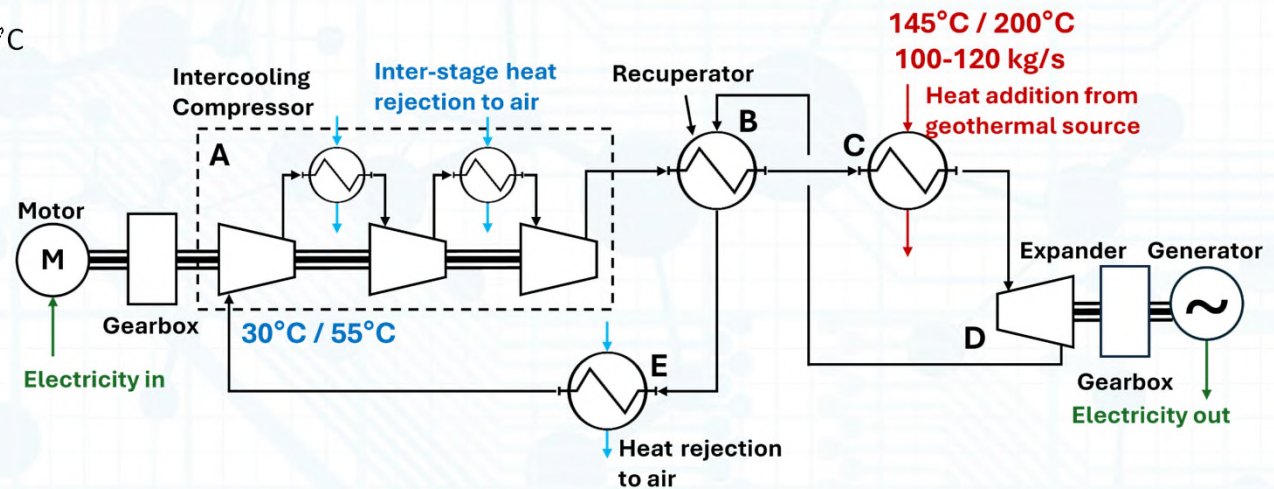

Key Cost Assumptions

Component	Unit	Equation	Weiland Component
Compressor	MWsh	$C = 1,230,000 \cdot p^{0.3992}$	Radial IG Compressor
Turbine	MWsh	$C = 406,200 \cdot p^{0.8}$	Radial Turbine
Primary Heater	MWth	$C = 632,900 \cdot Q^{0.60}$	Recuperator
Recuperator	W/K	$C = 49.45 \cdot UA^{0.7544}$	Recuperator
Process Cooler	W/K	$C = 32.88 \cdot UA^{0.75}$	Direct Air Cooler
Intercooler	W/K	$C = 32.88 \cdot UA^{0.75}$	Direct Air Cooler
Generator	MWe	$C = 108,900 \cdot p^{0.5463}$	Generator
Motor	MWe	$C = 399,400 \cdot p^{0.6062}$	Motor
Gearbox	MWsh	$C = 177,200 \cdot p^{0.2434}$	Gearbox

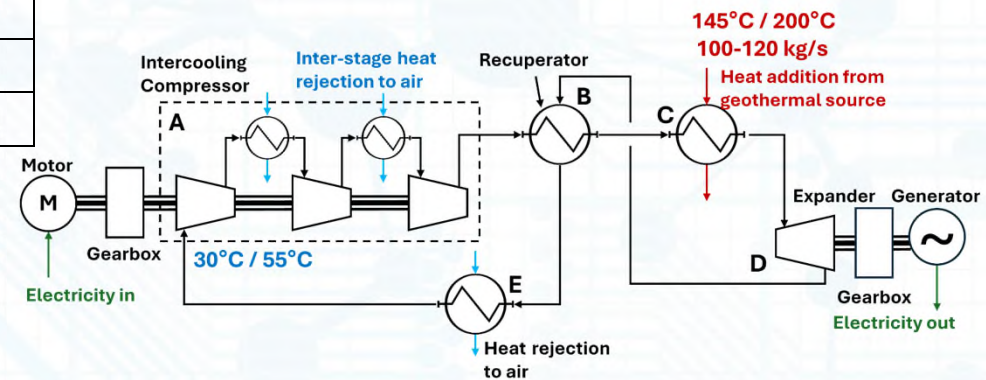

Results & Discussion



Key Cost Assumptions

Component	Unit	Equation	Weiland Component
Compressor	MWsh	$C = 1,230,000 \cdot p^{0.3992}$	Radial IG Compressor
Turbine	MWsh	$C = 406,200 \cdot p^{0.8}$	Radial Turbine
Primary Heater	MWth	$C = 632,900 \cdot Q^{0.60}$	Recuperator
Recuperator	W/K	$C = 49.45 \cdot UA^{0.7544}$	Recuperator
Process Cooler	W/K	$C = 32.88 \cdot UA^{0.75}$	Direct Air Cooler
Intercooler	W/K	$C = 32.88 \cdot UA^{0.75}$	Direct Air Cooler
Generator	MWe	$C = 108,900 \cdot p^{0.5463}$	Generator
Motor	MWe	$C = 399,400 \cdot p^{0.6062}$	Motor
Gearbox	MWsh	$C = 177,200 \cdot p^{0.2434}$	Gearbox

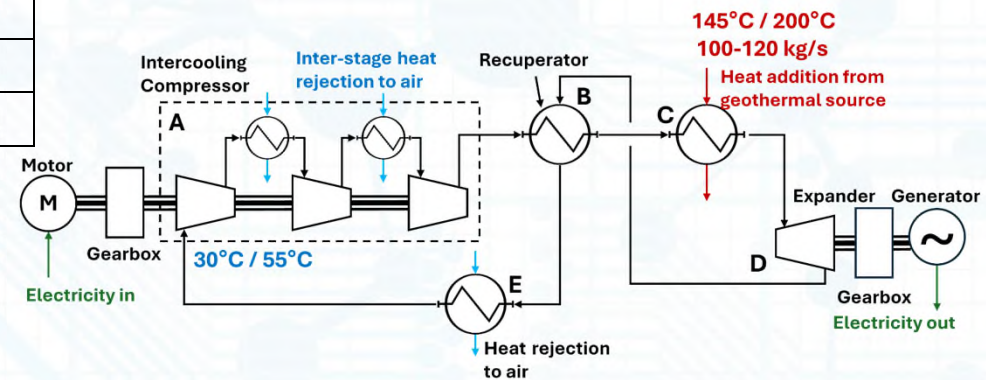

4 Different Cases were studied for different configurations

Wellhead/Ambient Conditions

Case Number	Case	Ambient Temperature	Source Temperature
1	Design Point	25°C	200°C
2	High Ambient Temperatures	50°C	200°C
3	Low Heat Source Temperature	25°C	145°C
4	Worst Conditions	50°C	145°C

- With and without a recuperator
- Heat rejection performance
- Maximizing power vs minimizing costs

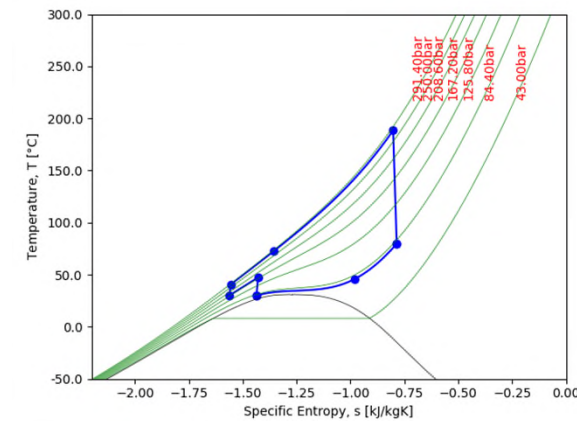
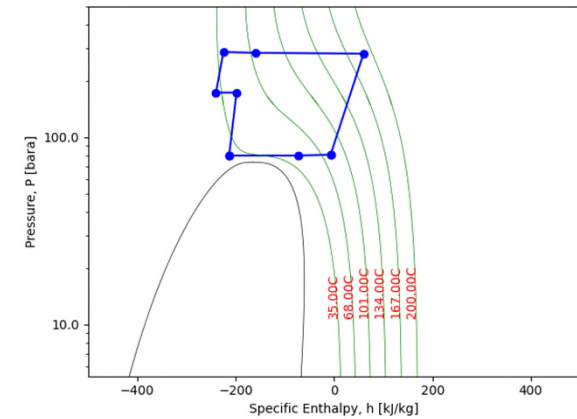

sCO₂ produces significant power at the design but struggles otherwise

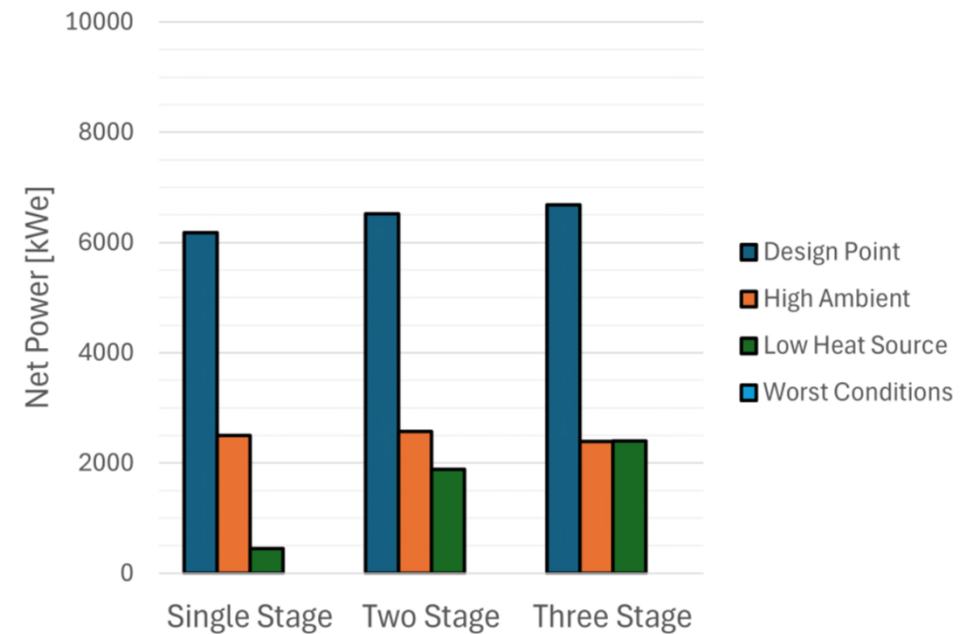
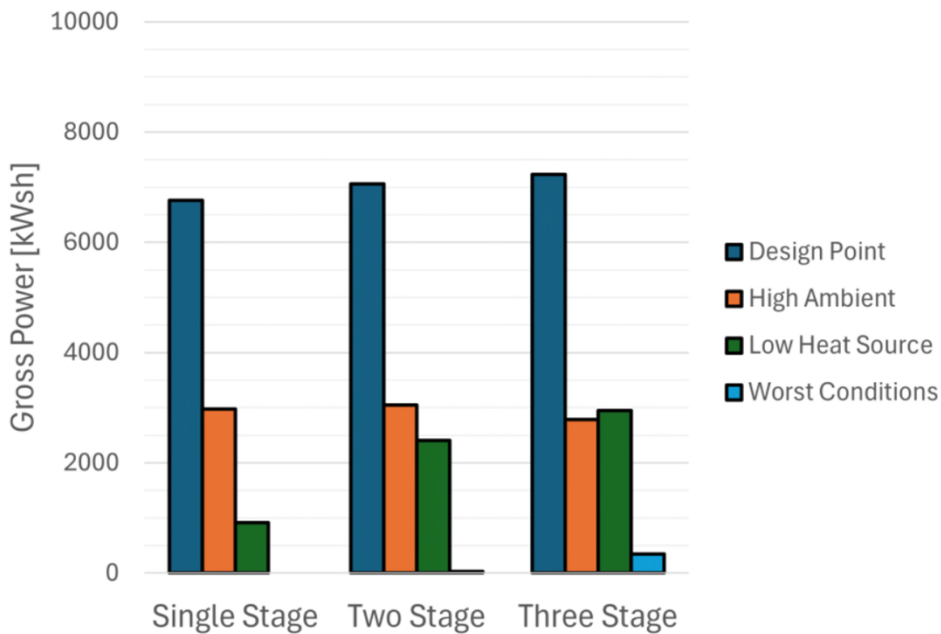

sCO₂ produces significant power at the design but struggles otherwise

Around 10% power increase with at least 1 intercooler

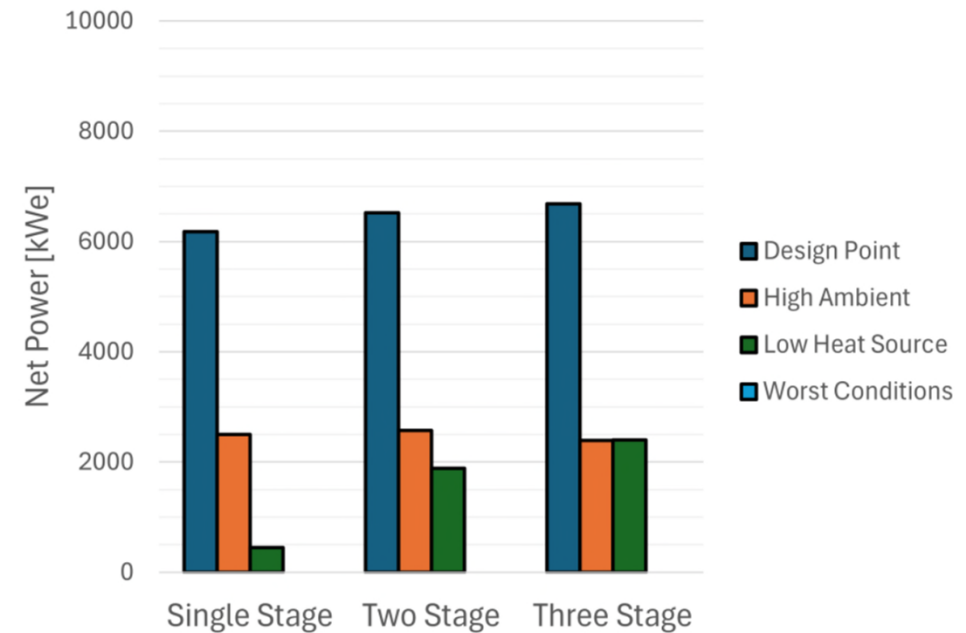
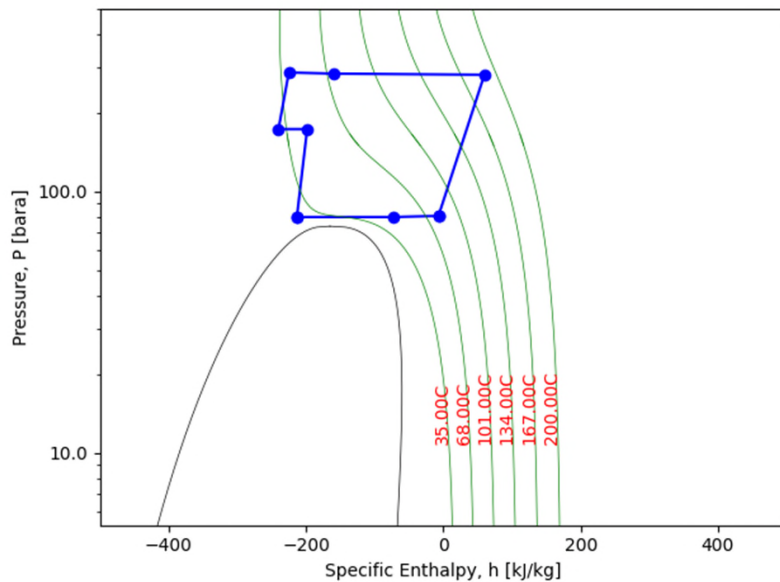

Optimizing for cost vs performance produced different cycles

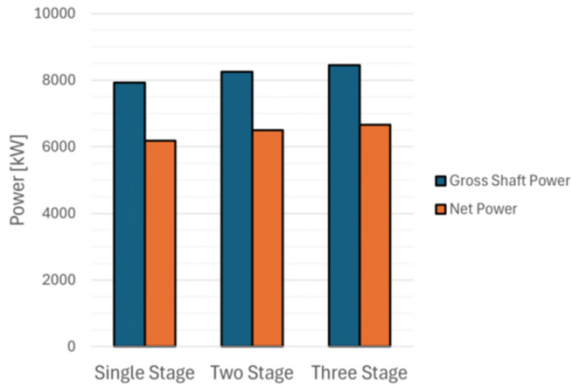

Maximizing net power output

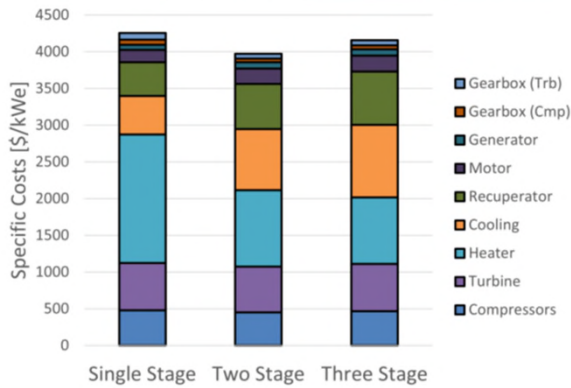
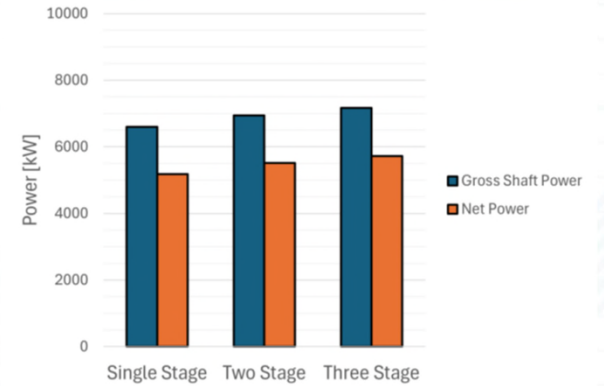

Minimizing specific cost of system output

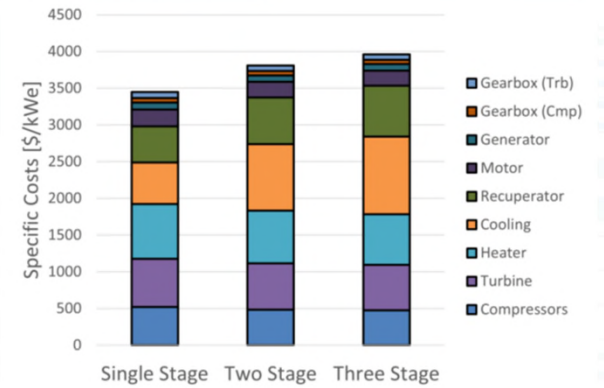

Optimizing for cost vs performance produced different cycles

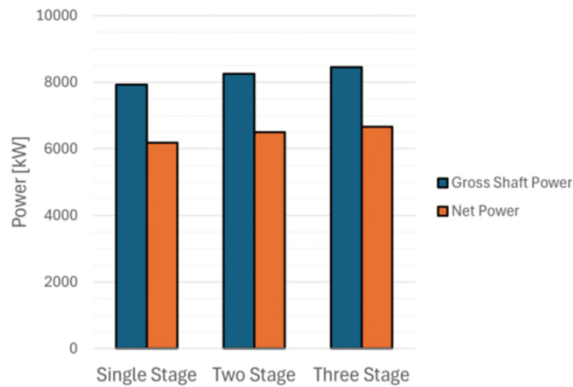

Maximizing net power output

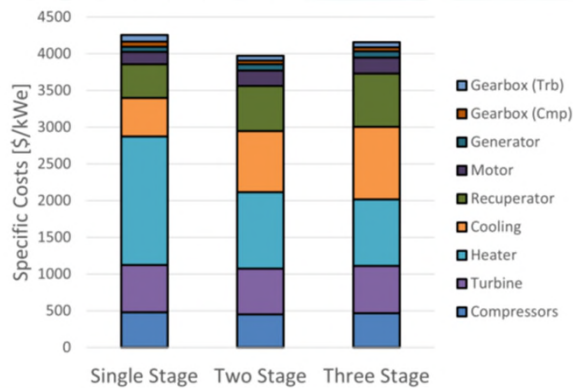
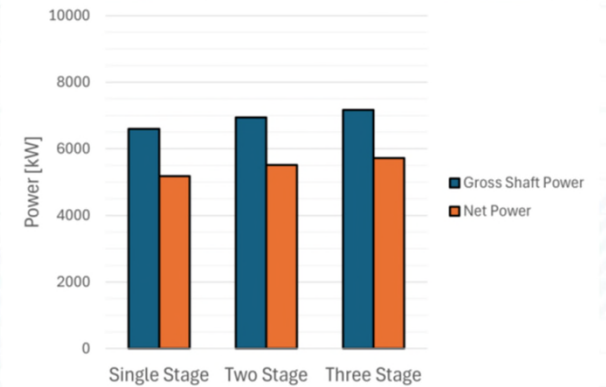

Minimizing specific cost of system output

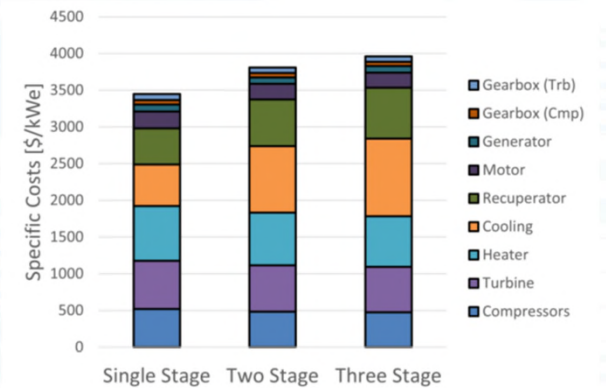

Removal of the recuperator reduced net power by 10-15%

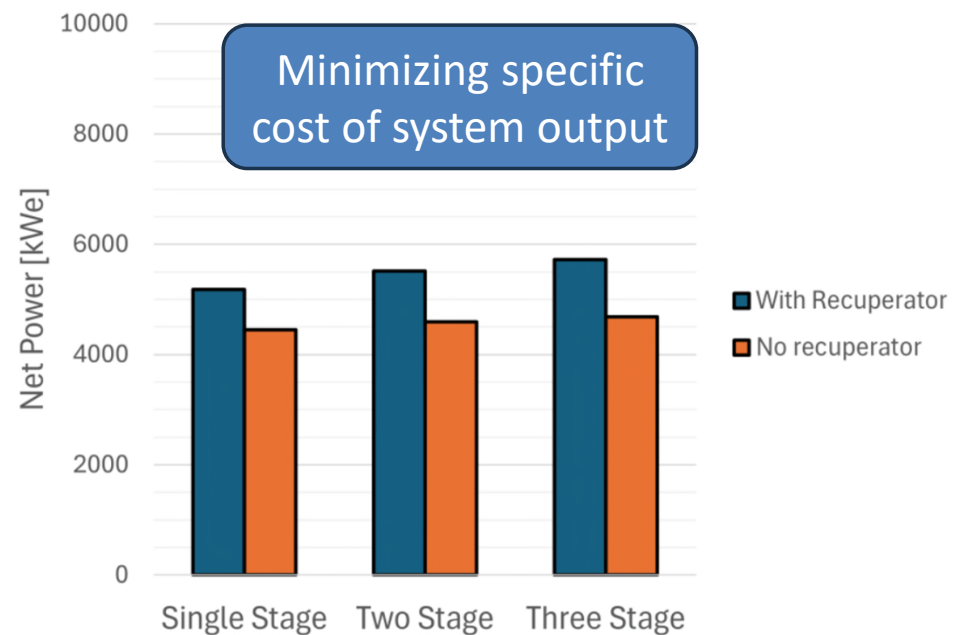
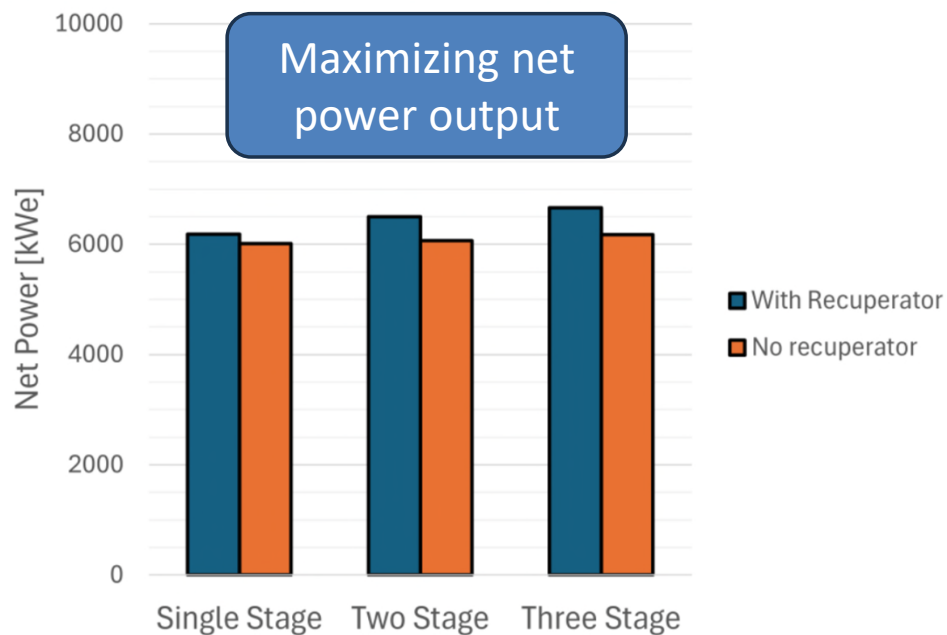

But significantly reduced the cost of the system

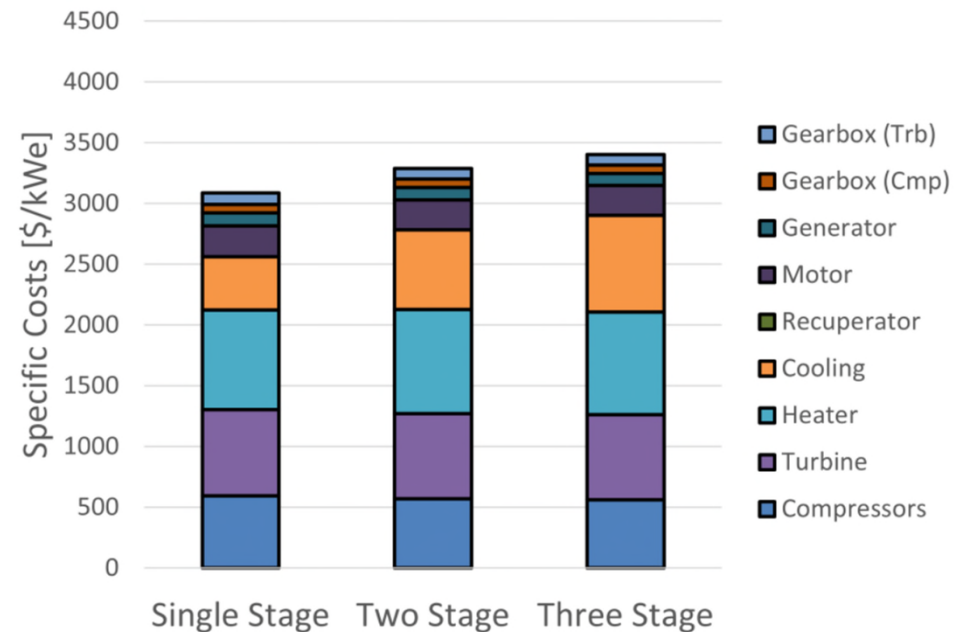
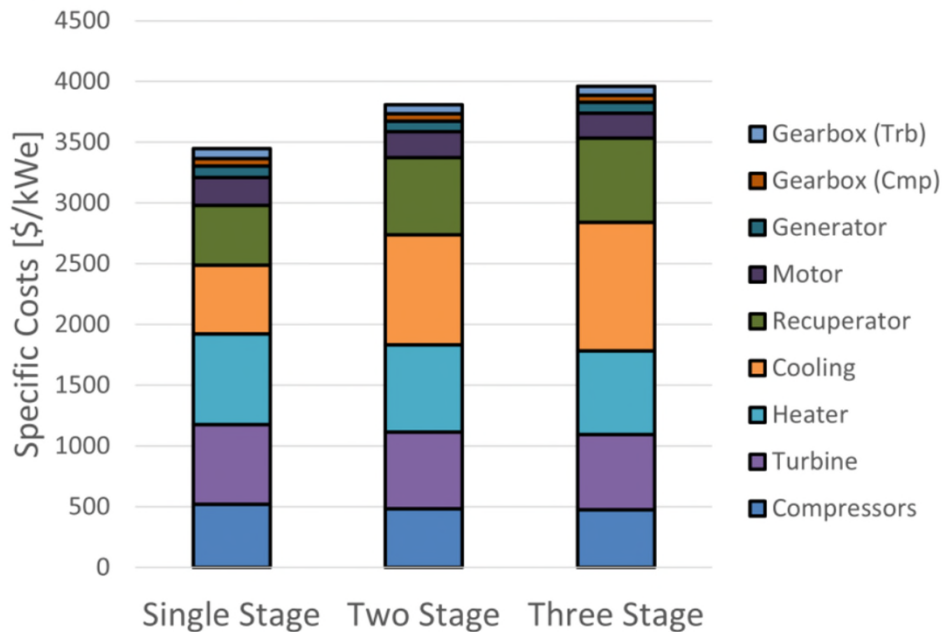

Conclusions

- sCO₂ cycle single stage with ambient ≤ 25 °C and WHT > 180 °C is performant
- sCO₂ cycle at WHT ≤ 145 °C does not produce power
- Two-stage intercooled compression helps stabilize performance when ambient conditions and WHT's swing
- Three-stage compression adds marginal benefit
- For WHT ≤ 200 °C, a recuperator can sometimes improve performance but additional costs may not make sense

Questions

Owen Pryor, Ph.D.
Senior Research Engineer
owen.pryor@swri.org

