

# Testing and Modeling of Subscale Ice-on-Coil Module as Low Temperature Reservoir for sCO<sub>2</sub> based Pumped Thermal Energy Storage Systems

## ECHOGEN

The 2026 International sCO<sub>2</sub> Energy Technologies Symposium

March 2 – March 5, 2026, Pittsburgh, PA

Paper # 074

Vamshi K. Avadhanula  
Systems Engineer  
Echogen Power Systems

Timothy J. Held  
Chief Technology Officer  
Echogen Power Systems

Jason D. Miller  
Engineering Director  
Echogen Power Systems



# Discussion Topics

- sCO<sub>2</sub> based Pumped Thermal Energy Storage
- Ice-on-Coil (IOC) technology
- IOC test loop
- Testing results and discussion
- IOC modeling and discussion
- Summary

# sCO<sub>2</sub> based Pumped Thermal Energy Storage System



- Electrical Grid reliability at risk as we move away from traditional energy sources and increase dependence on renewable energy sources.
- Echogen's sCO<sub>2</sub> based PTES technology

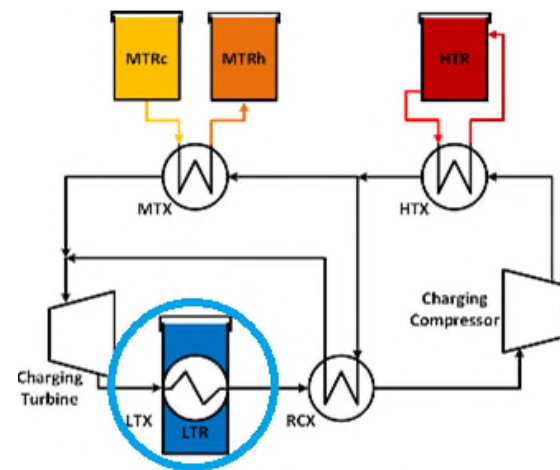
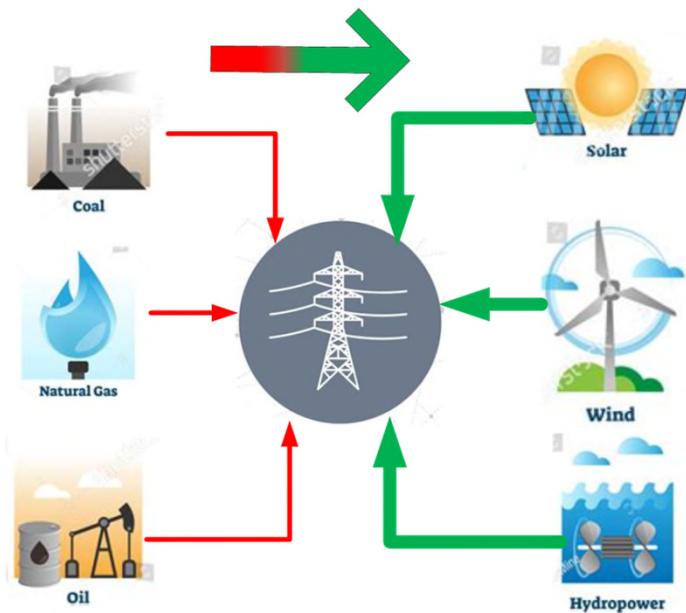

Heat Pump Cycle (Charge)

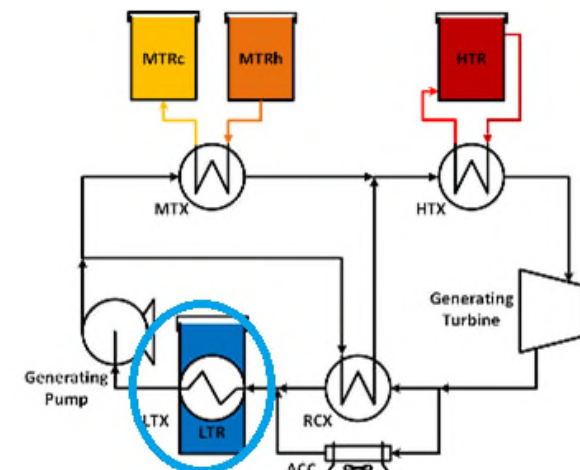

Power Cycle (Discharge)

Legend		
LT – Low Temperature	MT – Medium Temperature	HT – High Temperature
RC – Recuperative	_X – Heat Exchanger	_R – Reservoir
ACC – Air-cooled Condenser	_h – "hot"	_c – "cold"

ECHOGEN

# Commercial Scale IOC Installation



ECHOGEN

# Ice-on-Coil (IOC) Technology



- IOC mainly consists of embedded tube banks in static bath of water.
- **Charging:** Saturated CO<sub>2</sub>, at about  $-3^{\circ}\text{C}$  to  $-5^{\circ}\text{C}$ , flows through the embedded tubes causing the water to freeze on the outer surface of the tube transiently while vaporizing the CO<sub>2</sub>.
- **Generating:** Relatively warm CO<sub>2</sub> (about  $20^{\circ}\text{C}$ ) flows through the tubes causing the ice on the outer surface of the tube to melt while the CO<sub>2</sub> is cooled to saturated liquid conditions.

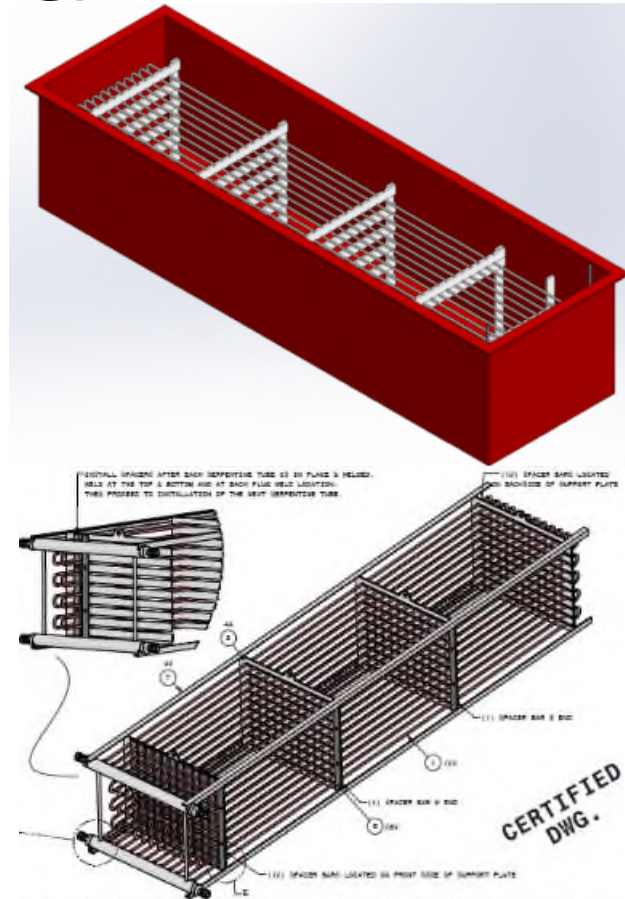

Tank = 130" LX 40" WX 28" H = 630 gal

ECHOGEN

# Ice-On-Coil Lab Test – Single line P&ID

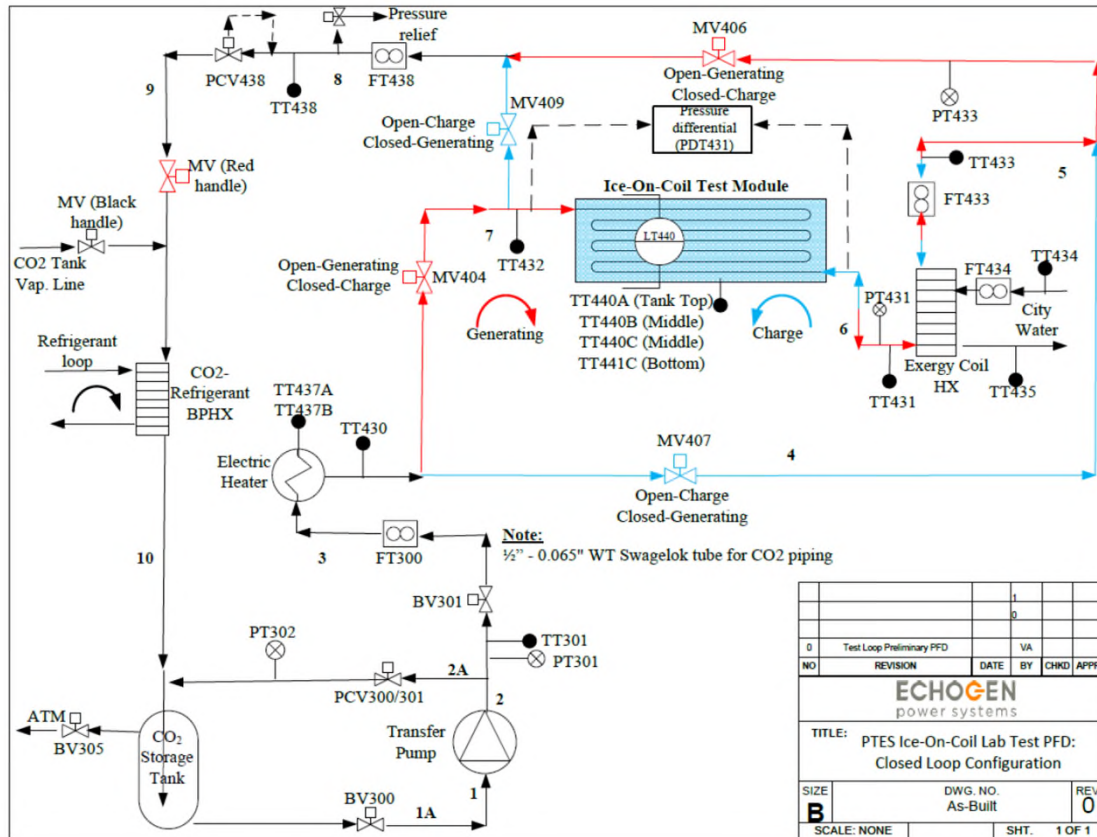

- Charge (ice making): 1-2-3-4-5-6-7-8-9-10
- Generate (ice melting): 1-2-3-7-6-5-8-9-10
- Three main control loops:
  - (i) CO<sub>2</sub> flow control: Transfer pump VFD
  - (ii) CO<sub>2</sub> supply temperature control: Electric heater
  - (iii) IOC CO<sub>2</sub> pressure control: PCV438 backpressure modulating control valve
- Test loop is well instrumented
- Ice mass: Using level measurement (LT440)

# Installed IOC Test Loop Pictures



a. IOC with tube bundle



b. Electric heater



a. IOC with tube bundle

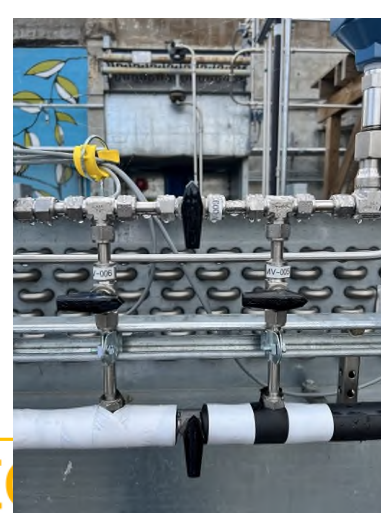

# Lab Test IOC Dimensions

Tank = 130" LX 40" WX 28" H = 630gal

Tank water vol = 545gal (with coils and headers installed in the tank)

IOC Physical Dimensions	
IOC one (1) tube length (ft)	100
Number of serpentine coils	12
Number of tube in one serpentine	10
IOC tube OD (in)	0.5
IOC tube wall thickness (in)	0.035
Vertical tube-to-tube distance (in)	2.156
Horizontal tube-to-tube distance (in)	2.063

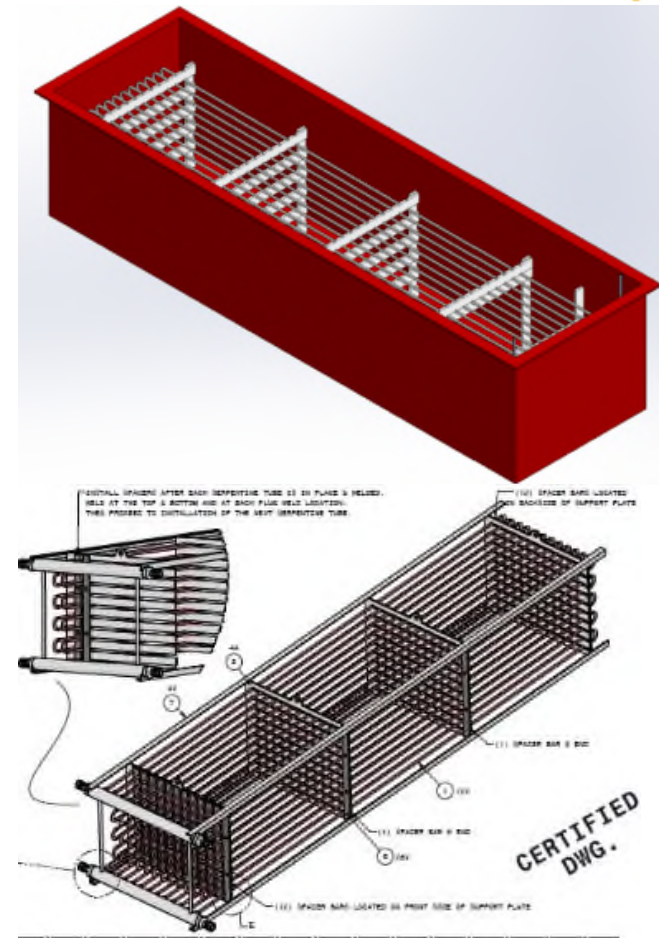

# IOC CO<sub>2</sub> Temperatures

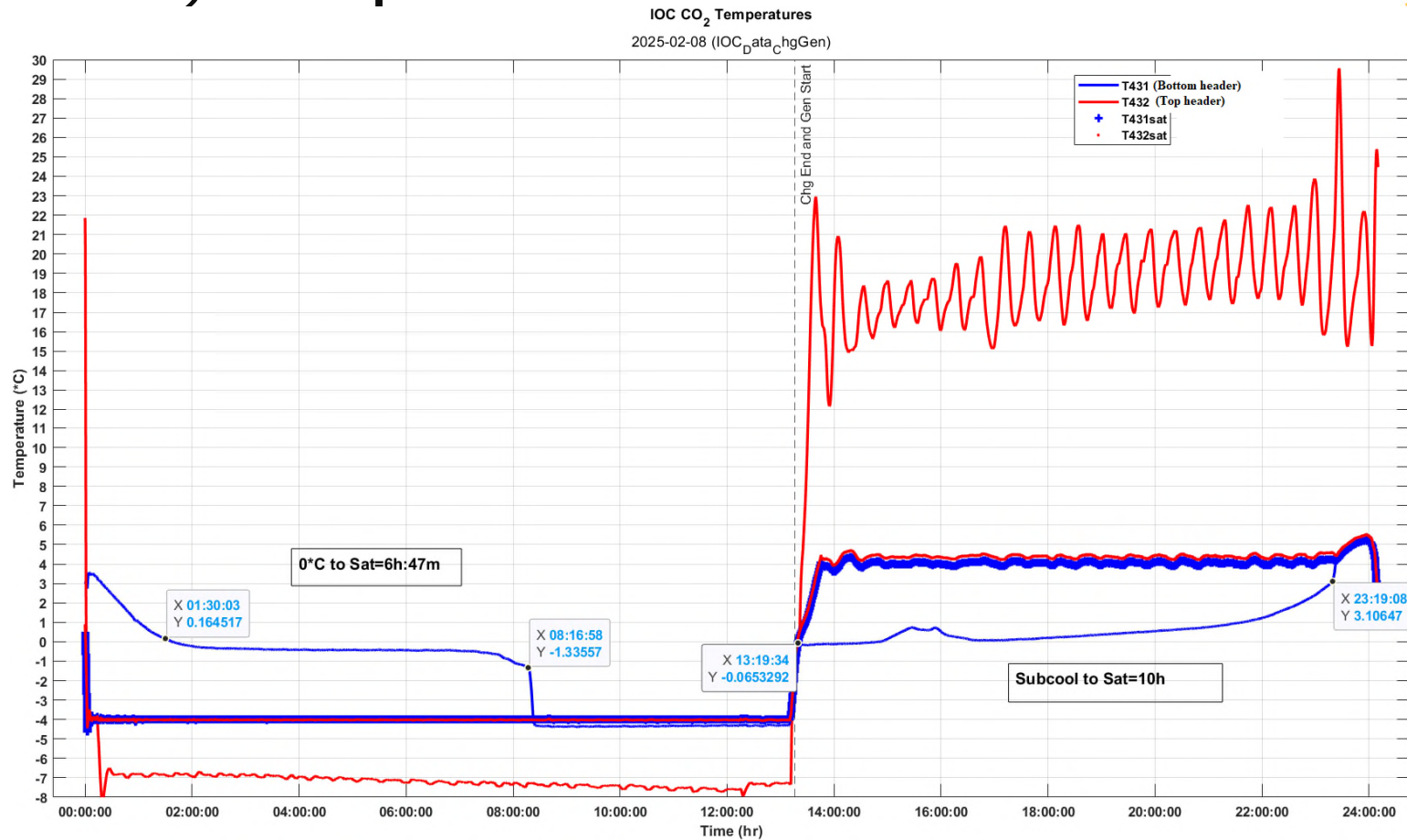

CO<sub>2</sub> discharge temperature, both during charge and generate test, is around 0°C.

ECHOGEN

# IOC Water Temperatures

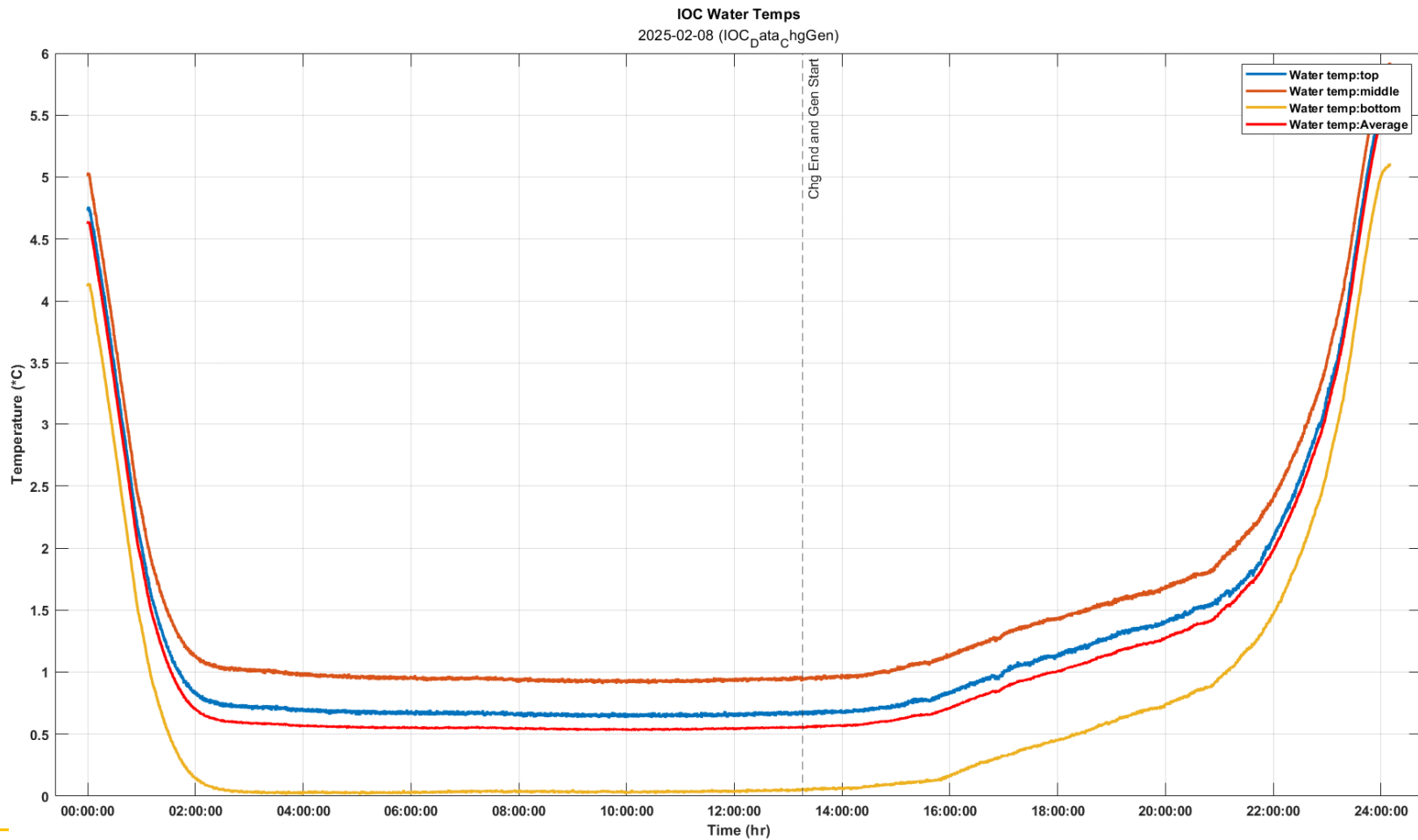

ECHOGEN

# IOC Heat Transfer Rate

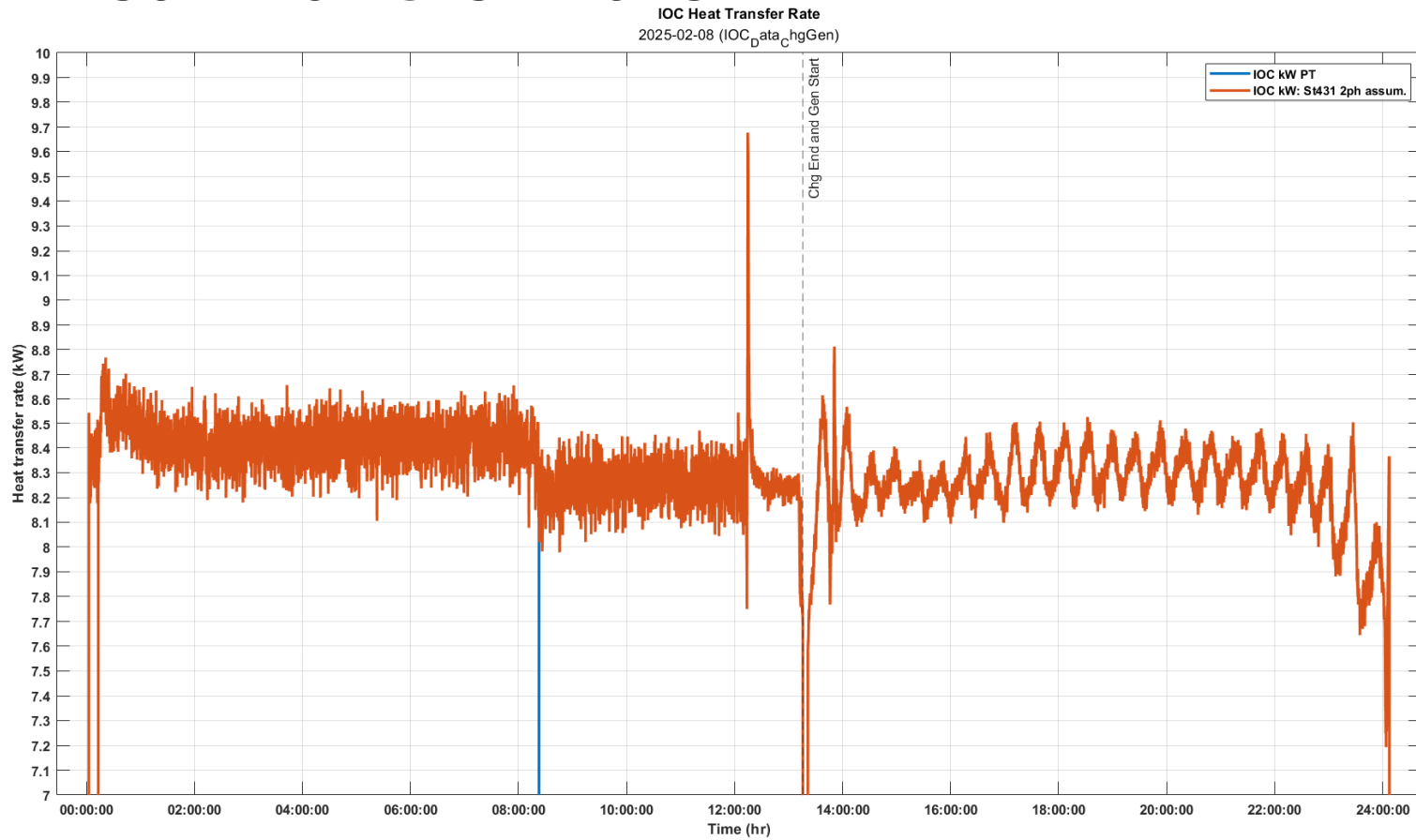

Tested IOC module was about 8.5 kW<sub>th</sub> systems

ECHOGEN

# IOC Pressure Control

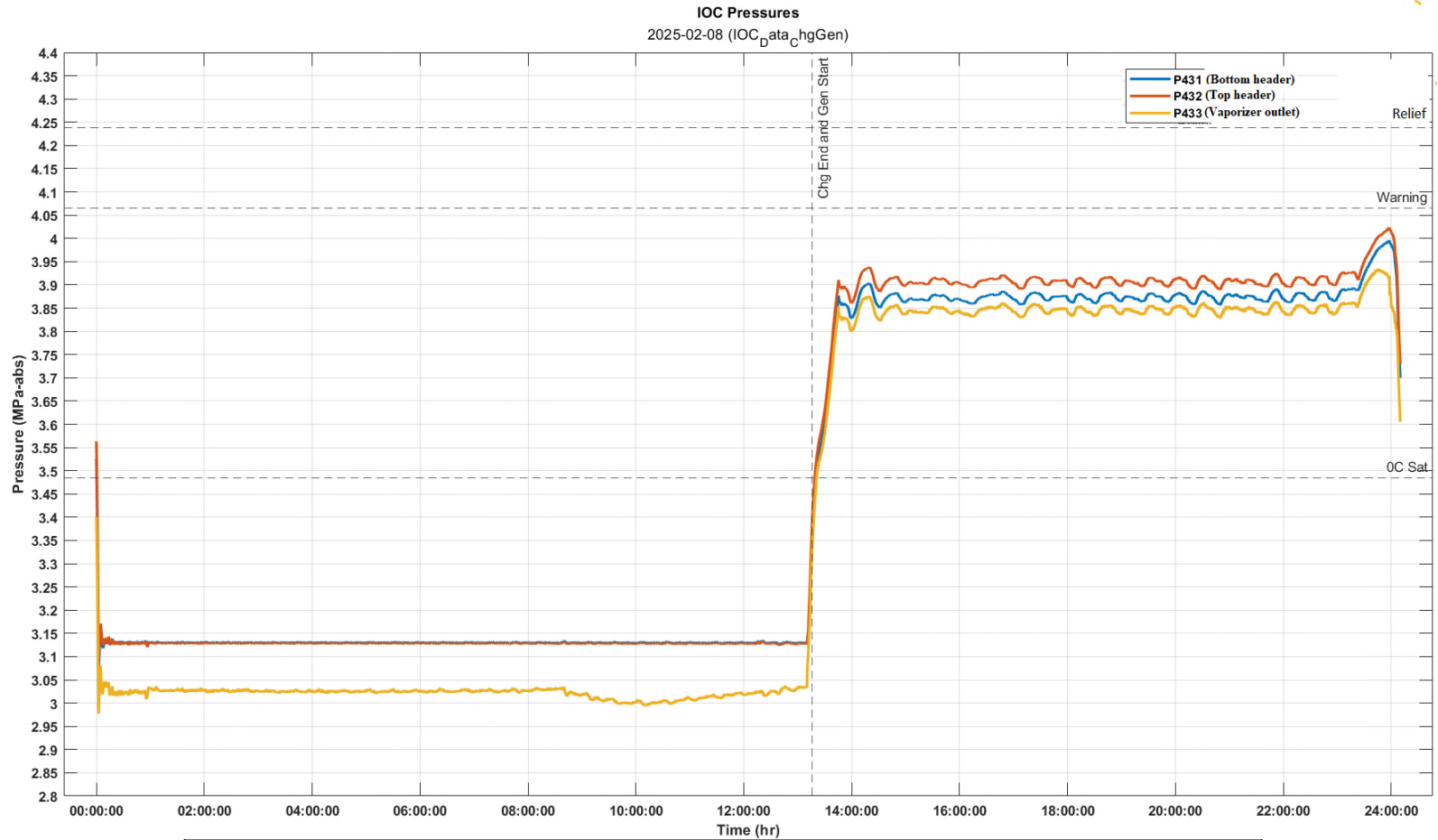

Stable control of IOC Pressure during charge and generate tests.

ECHOGEN

# IOC CO<sub>2</sub> Mass

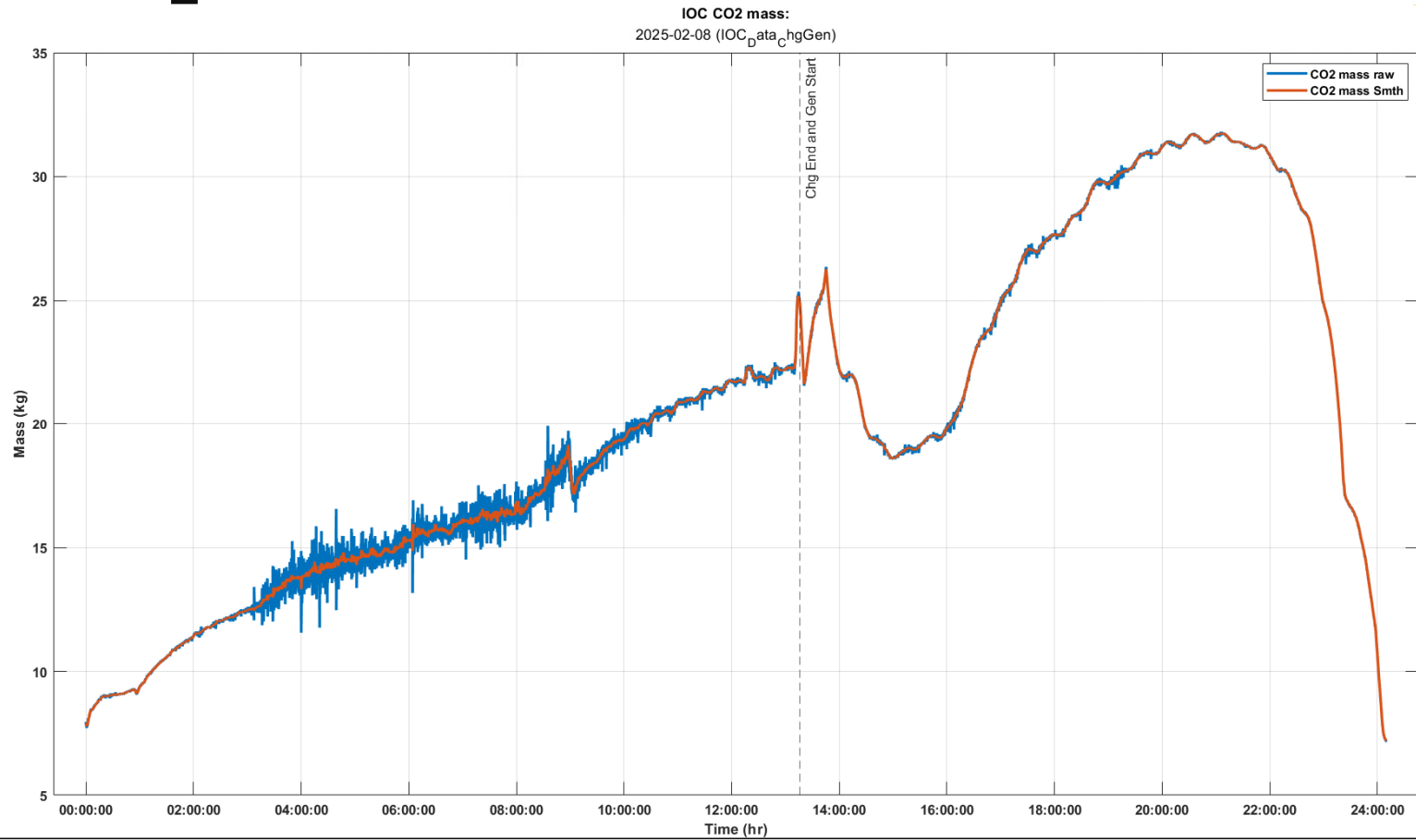

The test IOC module was installed on LoadCells for continuous CO<sub>2</sub> mass hold-up monitoring

ECHOGEN

# Ice/Water Side Analysis

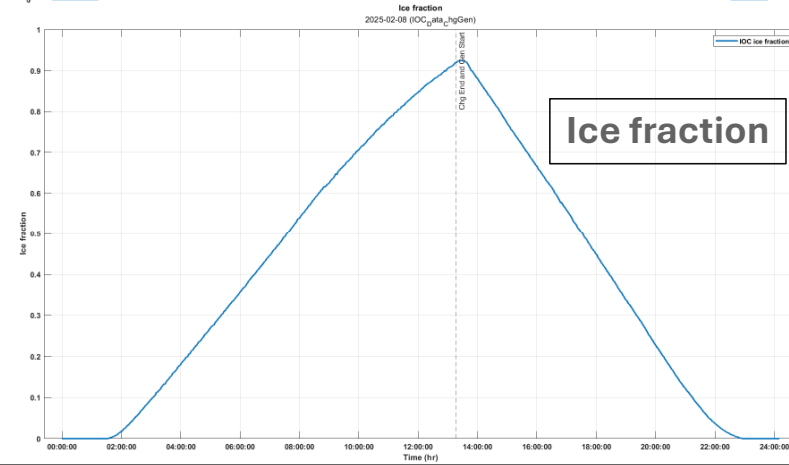
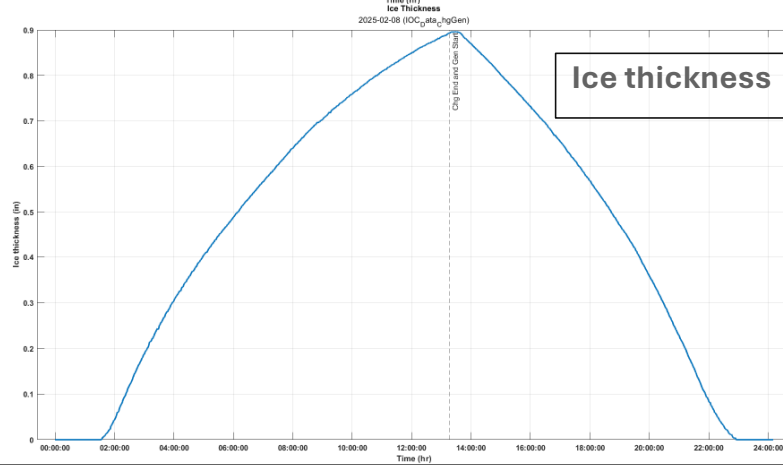
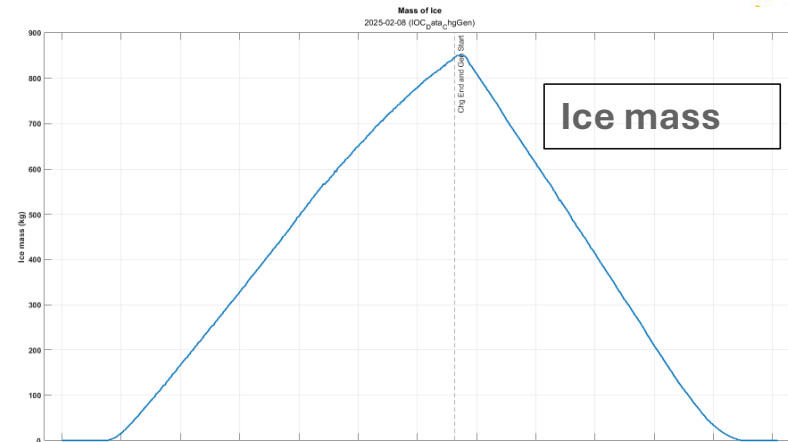
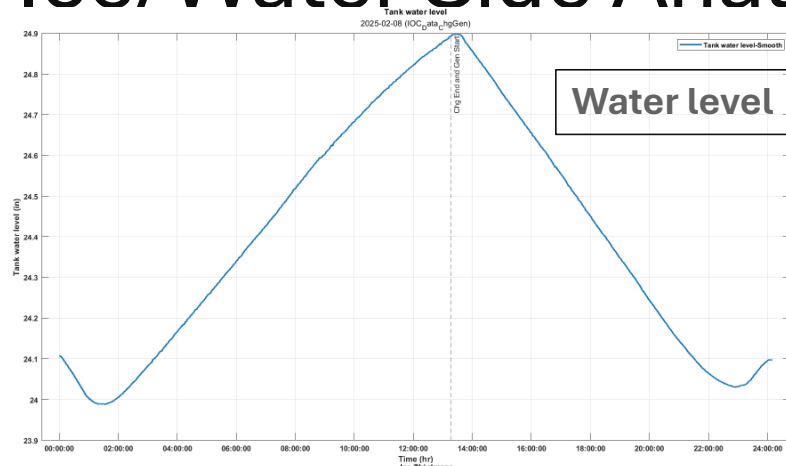

In calculating ice fraction, assumed all the ice is formed on the tubes – ignoring headers and IOC structural components.

# Ice-On-Coil: Max Ice Test

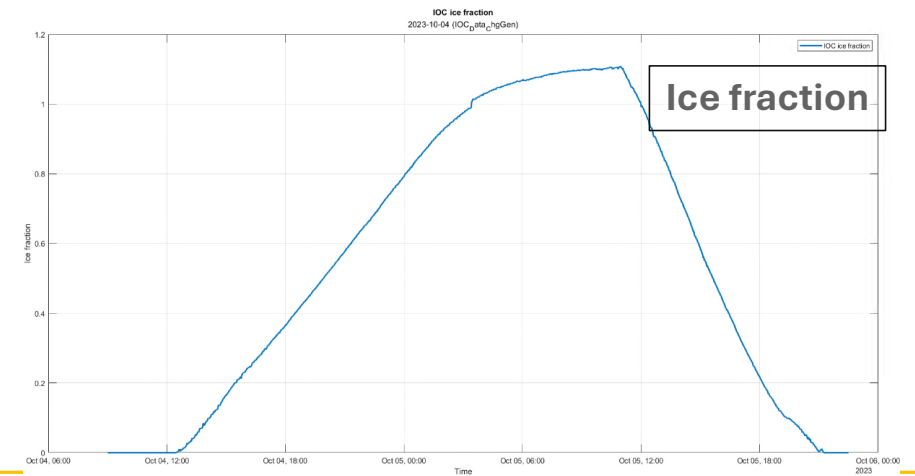
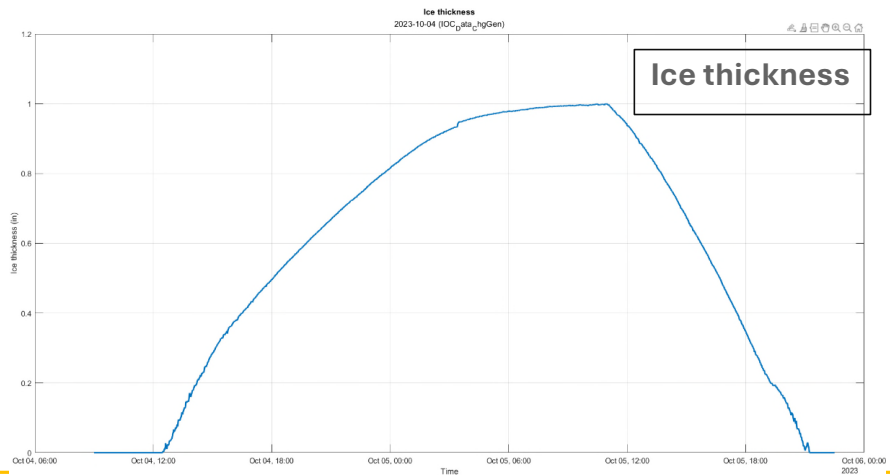
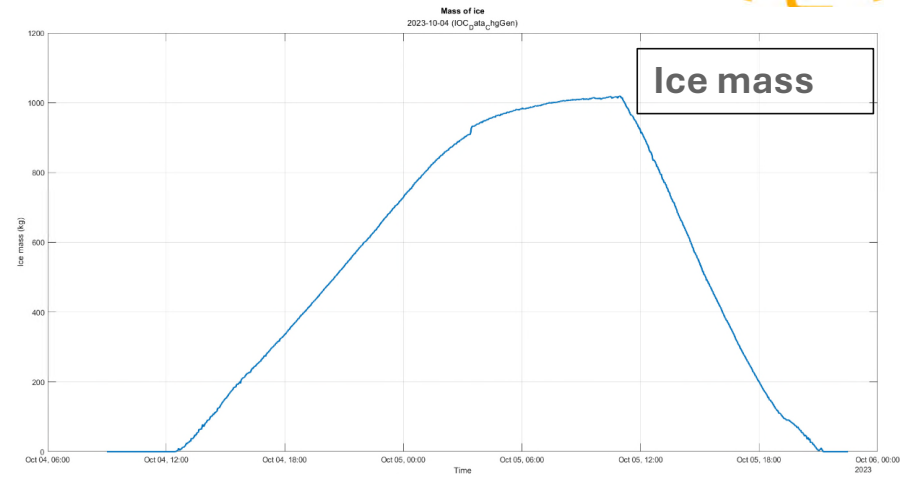
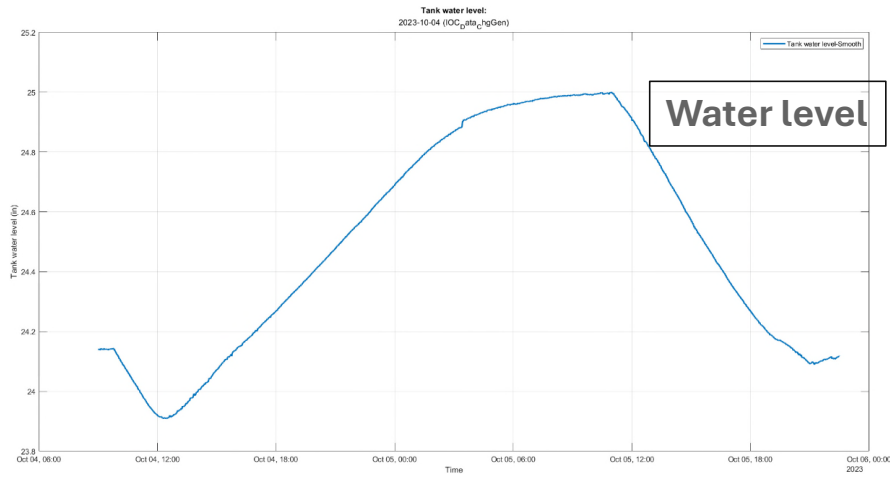

# Ice-On-Coil: Ice Formation

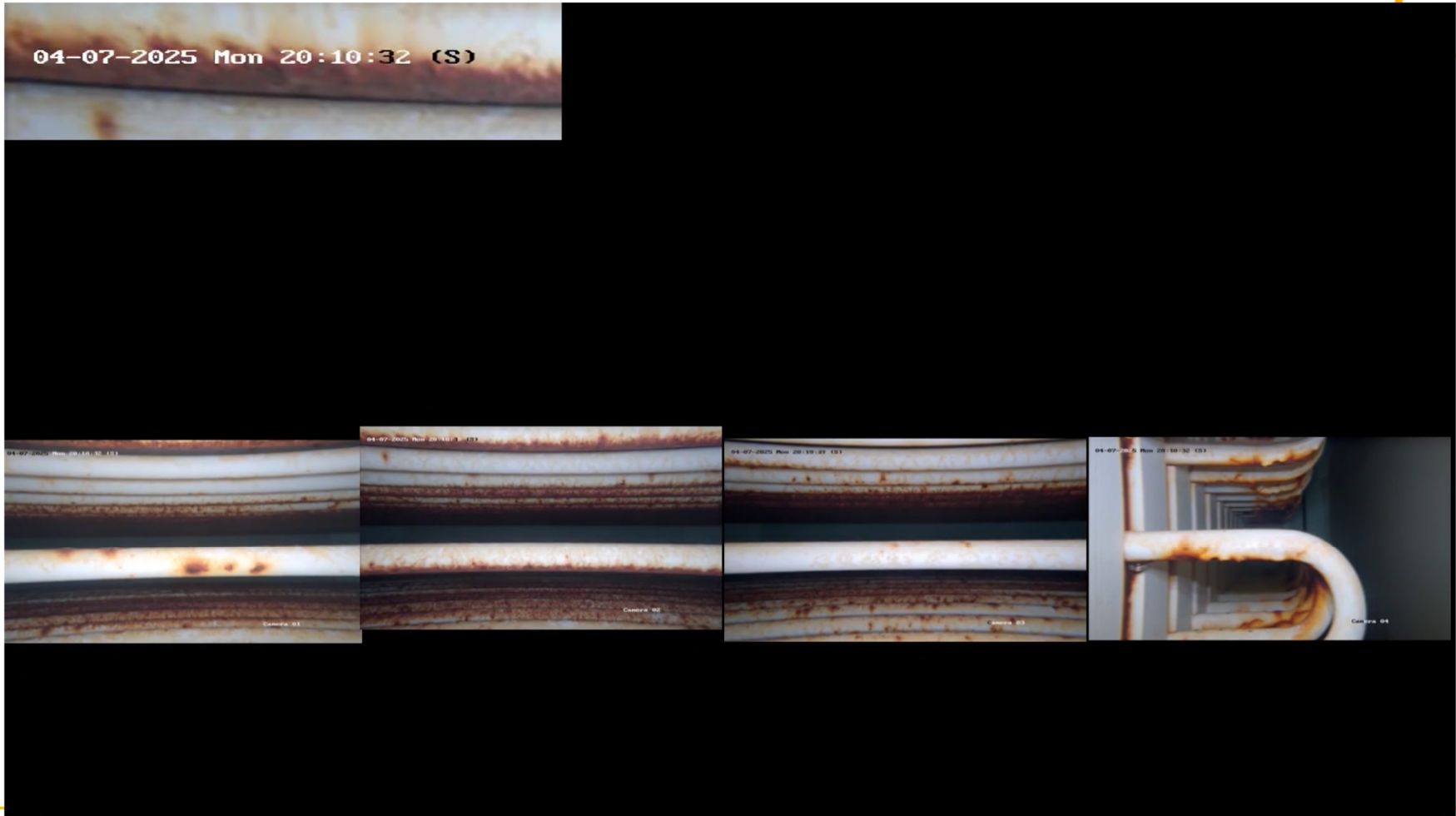

ECHOGEN

# Ice-On-Coil Project: Transient Model Development



- GT-Suite 1D simulation for CO<sub>2</sub> side heat transfer and pressure drop estimations.
- Echogen built in-house FORTRAN code for water/ice side heat transfer estimations.
- CO<sub>2</sub> side heat transfer correlations:
  - Single-phase: Dittus-Boelter
  - Two-phase condensation: Dobson (1998)
  - Two-phase evaporation: Yoshida (1983)
- Water side Lumped heat capacitance model.

# IOC Transient Model: Validation



- The developed model was validated against test data.

Model Inputs (IOC Physical Dimensions)	
Number of tubes	12
Tube OD (mm)	12.7
Tube wall thickness (mm)	0.889
Length of tube (total) (m)	30.48
Length of tube single element (m)	0.924
Tube-to-tube distance (mm)	53.34

Boundary conditions	
CO <sub>2</sub> inlet temperature or quality	
CO <sub>2</sub> flow rate	
CO <sub>2</sub> IOC pressure	
Initial water temperature	
Model outputs verified	
CO <sub>2</sub> outlet temperature	
Mass of ice	
Heat transfer rate	
Average water temperature	

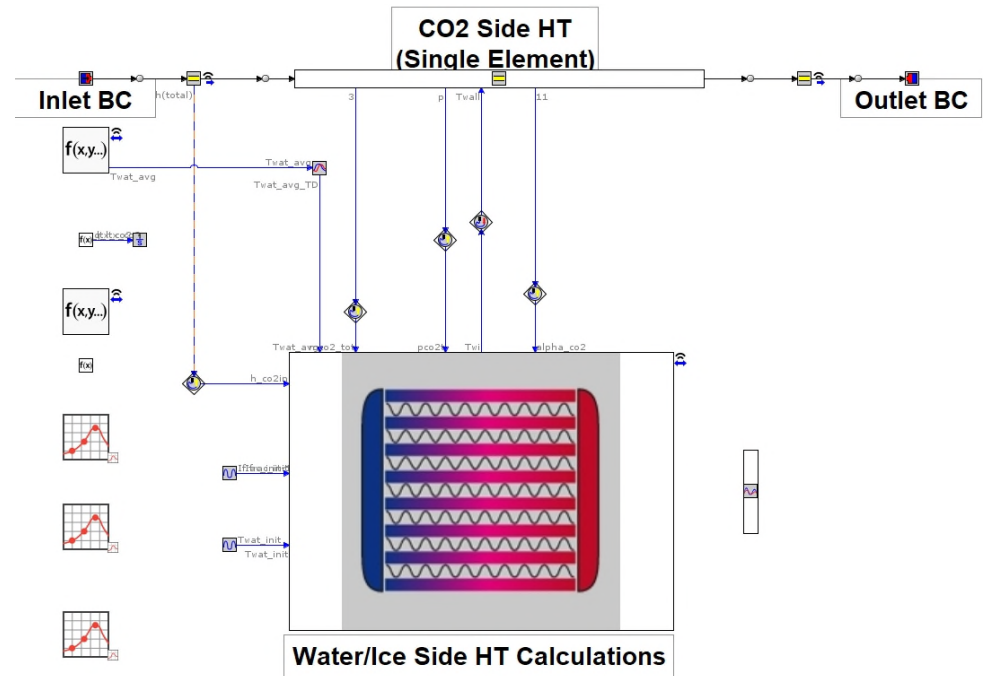

# IOC Transient Model: Validation: $-3^{\circ}\text{C}$ Saturation (3.21MPa)

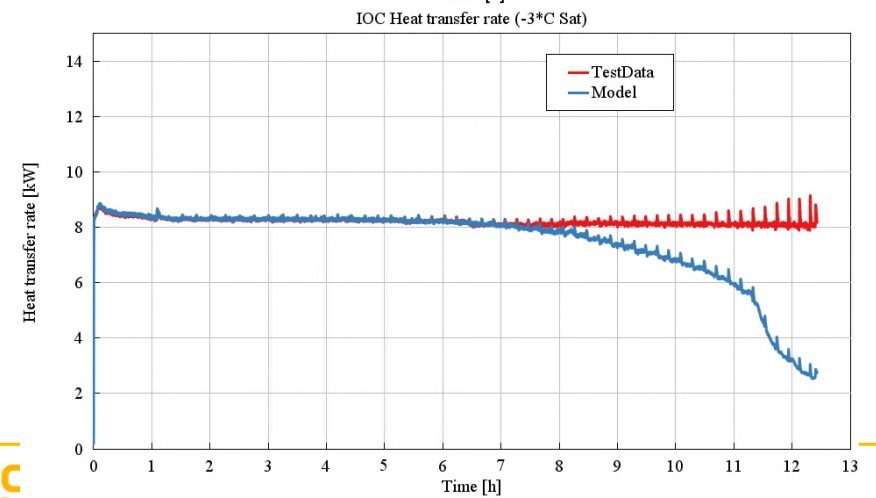
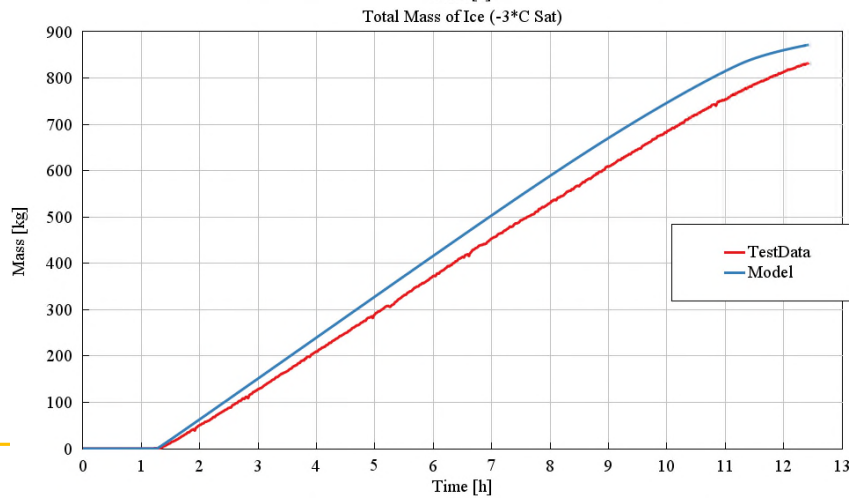
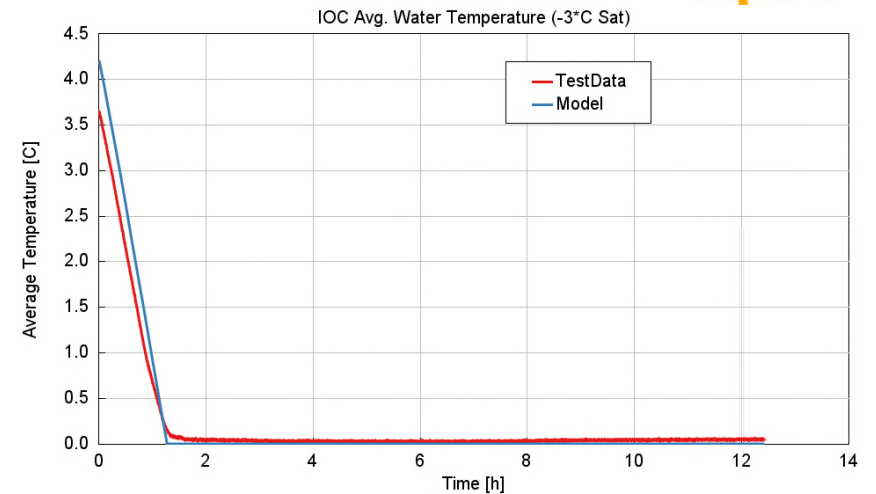
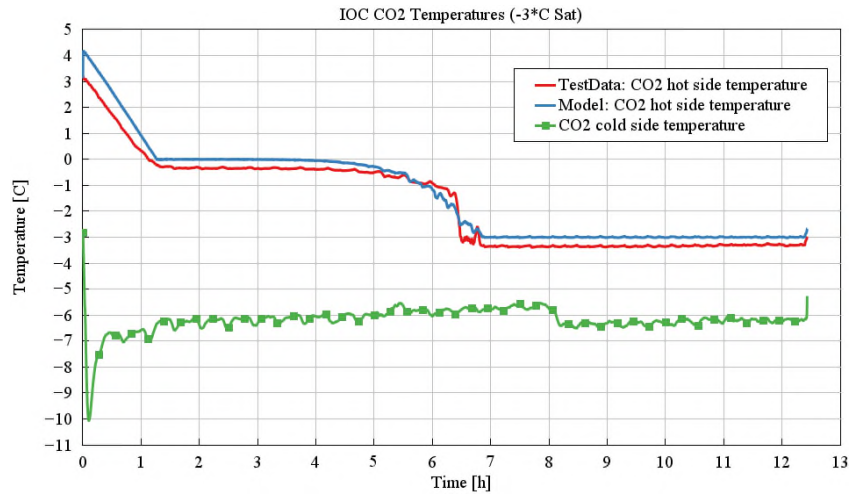

# IOC Transient Model: Validation: -4°C Saturation (3.13MPa)

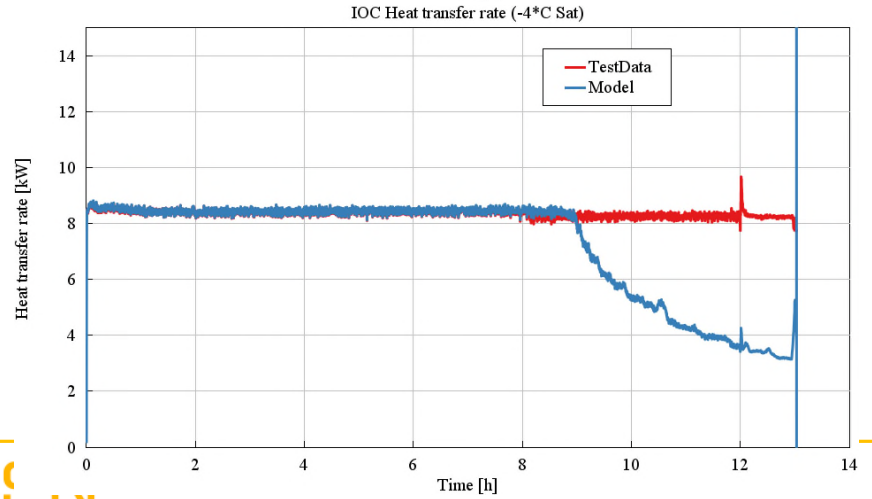
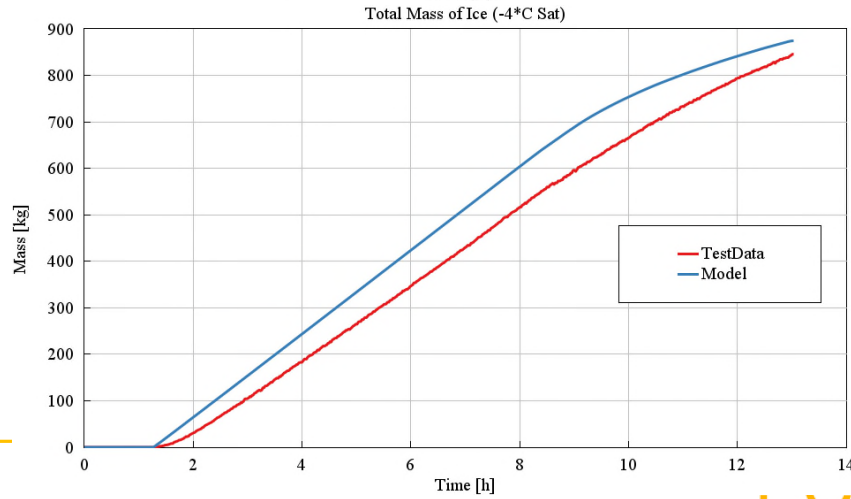
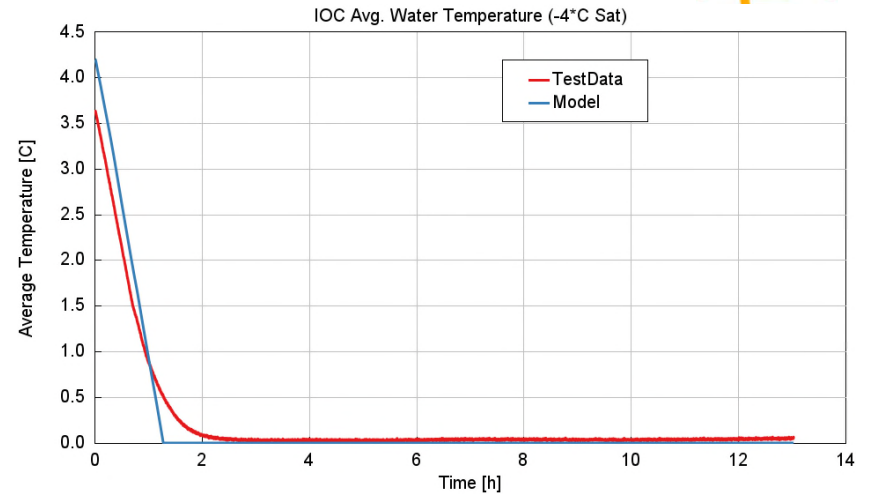
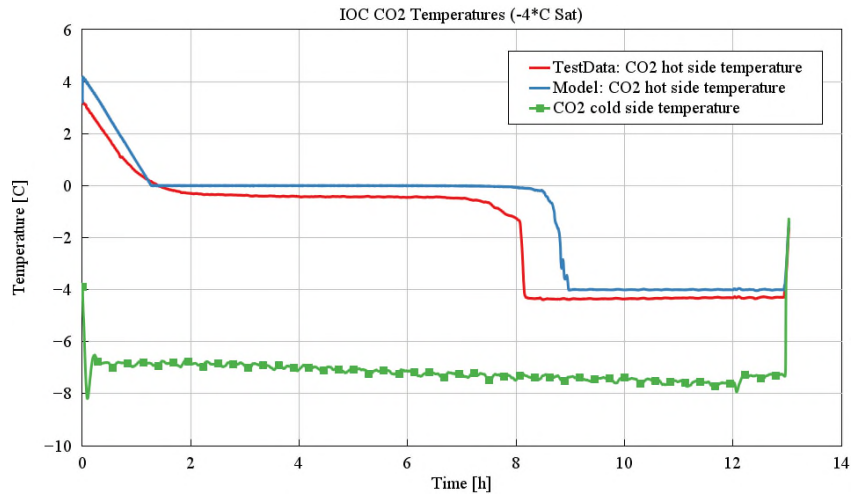

# IOC Transient Model: Validation: $-5^{\circ}\text{C}$ Saturation (3.046MPa)

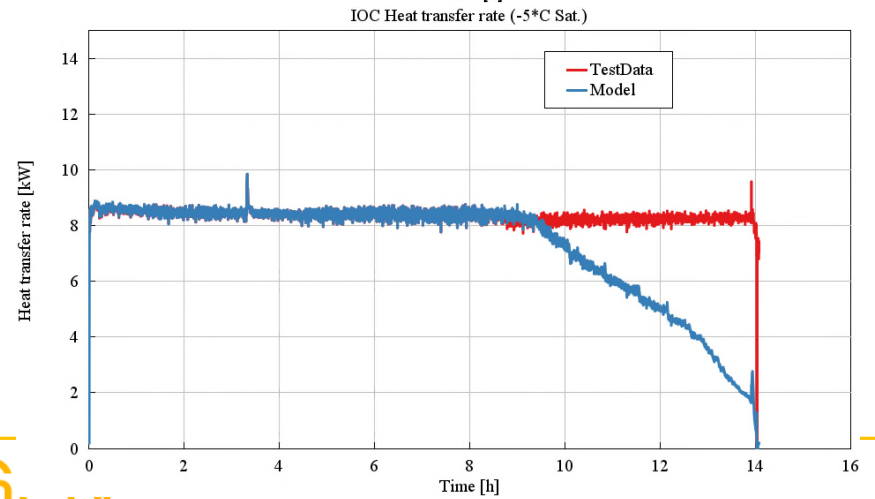
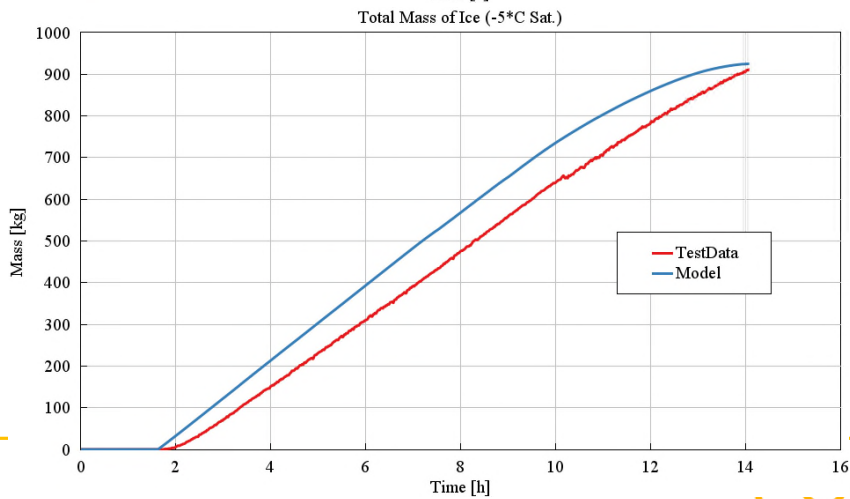
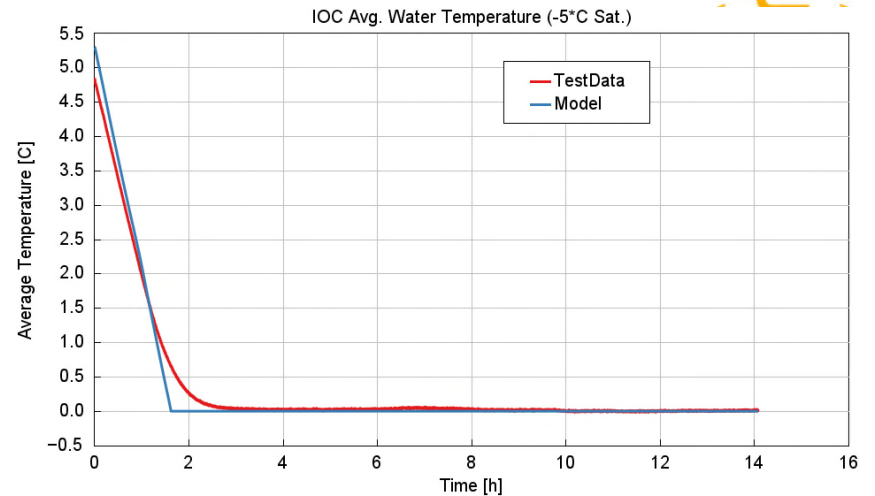
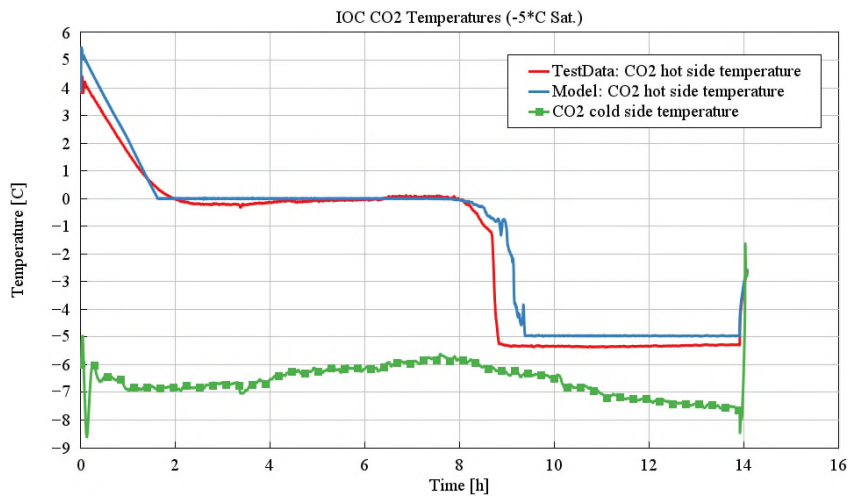

# IOC Tube Bundle Design Optimization based on Validated Model



Parameter	Function/Value/Range	Description
<b>Objective function</b>		
Objective function	Minimize:(Total LTR cost)/kWh.	To minimize IOC total cost (\$/kWh) by satisfying constraints by end of the transient run (i.e. 100hr for GVEA). Total LTR cost = (Total cost of tube) + (Cost of tank)
<b>Boundary Conditions</b>		
CO <sub>2</sub> Flowrate (kg/s)	116.75	POLAR PTES CO <sub>2</sub> flow rate
CO <sub>2</sub> Inlet Quality (kg/kg)	0.015	POLAR PTES IOC CO <sub>2</sub> inlet quality
CO <sub>2</sub> IOC Pressure (MPa)	3.18	POLAR PTES IOC CO <sub>2</sub> pressure
<b>Variables and Range for Optimization</b>		
Tube diameter (TubeOD, in)	0.5	Fixed for POLAR PTES project based on previous experience
Number of tubes (N <sub>tube</sub> )	4000 to 50000	
Adjacent tube-to-tube distance	(TubeOD+1mm) to 400mm	
Tube length	33.4m (109.5ft) to 305.4096m (1002ft)	
<b>Constraints</b>		
IOC pressure drop	≤ 16psi	
IOC charge outlet temperature	≥ 1°C superheat at IOC pressure at the end of transient run	
<b>Design Optimization Solution</b>		
Number of Tubes (N <sub>tube</sub> )	12918	
Adjacent tube-to-tube distance	139.56 mm (5.5 in)	
Tube length	128.24 m (420.7 ft)	



# Summary

- Design and installation of closed-loop sub-scale IOC system complete.
- Commissioning and operation procedures completed.
- Tested the installed IOC for charge and generate cycles in various test configurations.
- Lab scale tested IOC was about  $8.5\text{kW}_{\text{th}}$  module.
- Repeatability of test results confirmed.
- Developed the transient model for IOC system.
- Validated the model against test data.
- Transient model is being actively used to size IOC for commercial scale PTES systems.



**Thank you!**  
[vavadhanula@echogen.com](mailto:vavadhanula@echogen.com)  
**Paper # 074**

**Acknowledgements:**

This material is based on work supported by the **Department of Energy (Solar Energy Technology Office)** under Award Number(s) **DE-EE0009814**.

**Disclaimer:**

This report was prepared as an account of work sponsored by an agency of the United States Government. Neither the United States Government nor any agency thereof, nor any of their employees, makes any warranty, express or implied, or assumes any legal liability or responsibility for the accuracy, completeness, or usefulness of any information, apparatus, product, or process disclosed, or represents that its use would not infringe privately owned rights. Reference herein to any specific commercial product, process, or service by trade name, trademark, manufacturer, or otherwise does not necessarily constitute or imply its endorsement, recommendation, or favoring by the United States Government or any agency thereof. The views and opinions of authors expressed herein do not necessarily state or reflect those of the United States Government or any agency thereof.