



Hydraulic Shock Event and Analysis During Simple Cycle Testing at STEP Demo Facility

Presenter: Darryl Hino (GTI Energy)

Co-Author: Fernando Karg Bulnes (SwRI)

Co-Author: Mitchell Rhodes (SwRI)

Hydraulic Shock Event Summary

- The following will be described in this presentation
 - STEP Overview
 - STEP Facility initial piping design methodology and concerns
 - Instrumentation and Data Acquisition System used for vibrational and dynamic data
 - Hydraulic Shock events that occurred during Simple Cycle testing
 - Test data validation of the Flownex dynamic model and assessment of worst-case hydraulic shock event
 - Development and utilization of the dynamic CAESAR piping model to implement piping system modifications
 - Impact of piping system modifications on subsequent hydraulic shock events

STEP Demo Program Overview

- STEP: Supercritical Transformation of Electrical Power
- 10 MWe net sCO₂ Brayton test facility on Southwest Research Institute's (SwRI) campus in San Antonio, Tx
- The project is led by GTI Energy in partnership with SwRI and GE Vernova Advanced Research
- Sponsored by the U.S. Department of Energy (DOE), National Energy Technologies Laboratory (NETL)
- Project objectives include, but not limited to:
 - Demonstrate the operability of the sCO₂ cycle
 - Verify the performance of components (turbines, recuperators, and compressors, etc.)
 - Show potential for producing lower cost electricity in relevant applications
 - Demonstrate pathway for a thermodynamic cycle efficiency greater than 50% in large scale (100 MWe and greater) power generation applications



STEP Facility in San Antonio, TX

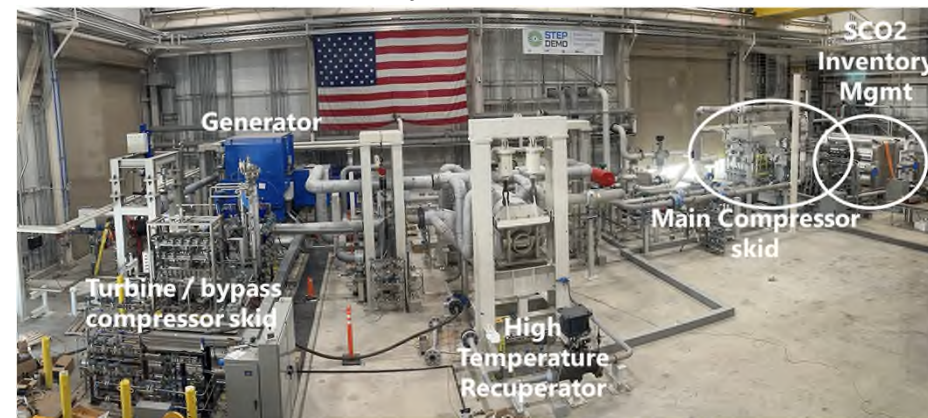

STEP Facility Layout: Simple Cycle Configuration

Simple Cycle Overview

1. sCO₂ is heated in the natural gas fired heater
2. sCO₂ passes through the turbine stop and control valve (TSV) and turbine
3. High temperature recuperator (HTR)
4. sCO₂ main cooler
5. sCO₂ main compressor
 - Flow can divert from the main process loop through a recycle loop back to the main cooler, allowing for the compressors to be started independently, as well as anti-surge protection
6. Flow through the HTR then the heater

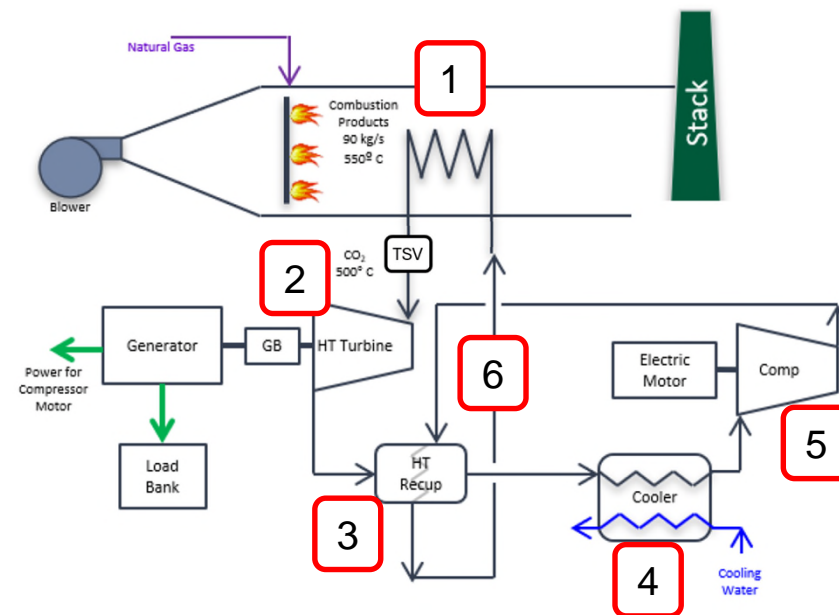

Simple Cycle Simplified Diagram

Piping System Design

- Process piping is divided into two sections and secondary piping:
 - High temperature: 740H
 - Low temperature: P91 (chrome moly) steel
 - Lube Oil and Cooling Water: Carbon Steel
- Challenging trade-off:
 - Thermal growth compliance vs. allowable equipment loads
 - High temperature = large thermal displacement
 - High operating temperatures and pressures result in compact sCO₂ equipment with low allow loads = small allowable displacements
 - Solution: Expansion Loops

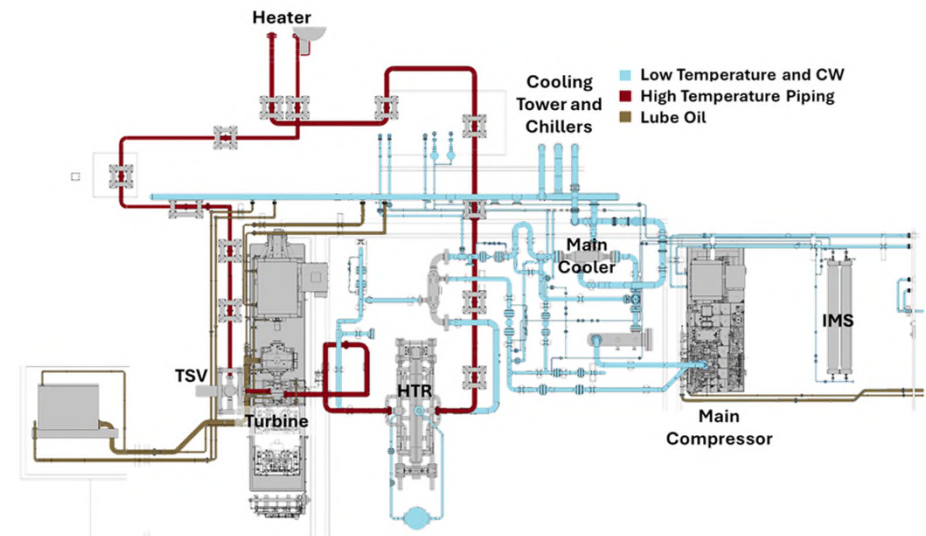

Simple Cycle Piping Diagram

- Design Methodology:
 - CAESAR II piping model
 - Strouhal Analysis
 - Modal Testing

Piping Data Collection

- FieldDAS: SwRI developed software package utilizing LabView and National Instruments hardware
 - Software is designed for flexibility for field support in dynamic data collection and analysis
 - Allows for both frequency and time domain data collection and visualization
 - Raw data can be stored for future processing
- At STEP, data was collected in the 1,000's Hz to ensure all transient events were recorded
- Measurements included:
 - 8 Tri axis accelerometers
 - 3 Dynamic pressure probes
 - 1 One-axis accelerometer
 - 1 Microphone

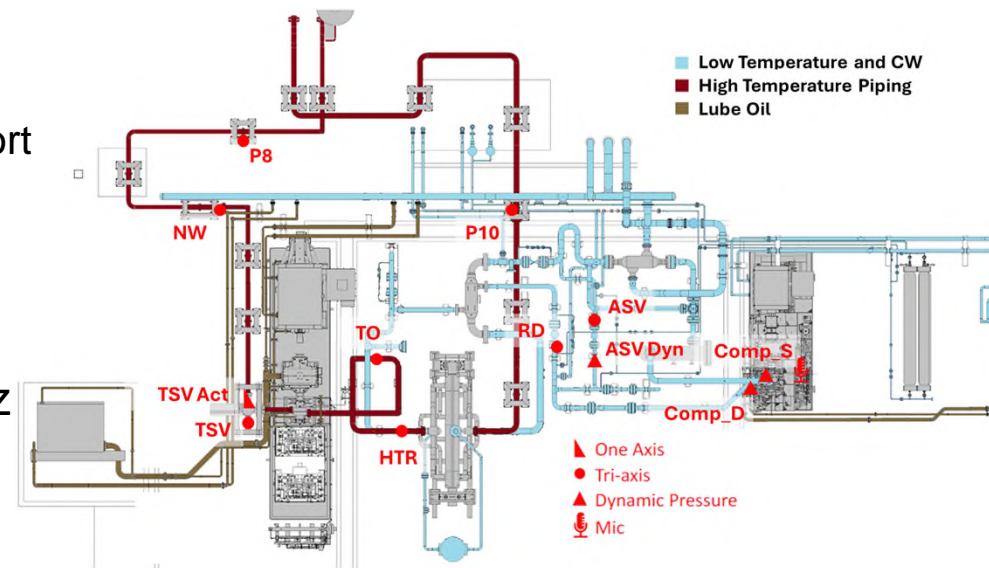

Installed Dynamic Instrumentation used with FieldDAS

Simple Cycle Testing Summary

- Hydraulic Shock Concern:
 - Rapid closing of the Turbine Stop and Control valves (TSV); TSV can close within 200 milliseconds
 - A pressure wave is generated and reflected through the system by the sudden stoppage of flow
 - Hot piping section supports include spring hangers which do not provide a lot of stiffness and cause a concern of displacement
- Three (3) emergency stops occurred during Simple Cycle Testing

Simple Cycle Test Summary

Test Campaign	Tests Completed	ESD Date	Reason Testing Ended
Feb 2024	3	Feb 08 2024	MC service required
May 2024	5	May 08 2024	Turbine service required
Sept - Oct 2024	11	Sept 27 2024	All test objectives achieved

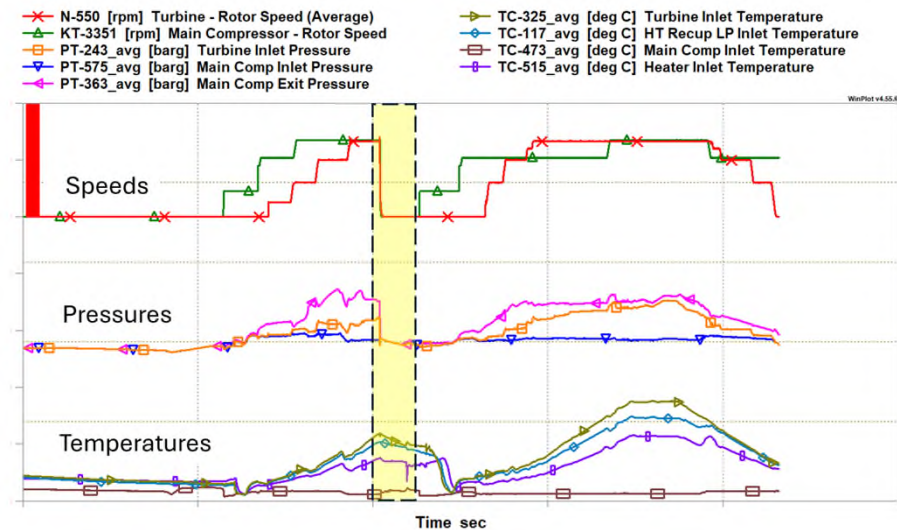

Sept 27, 2024, Planned Emergency Shutdown Data

Emergency Shutdown: Feb 8, 2024

- Feb 8, 2024, Hydraulic Shock Event:
 - Turbine operating at low speeds
 - First hydraulic shock event system experienced
 - Piping system experienced high vibration at low operating speeds and flows

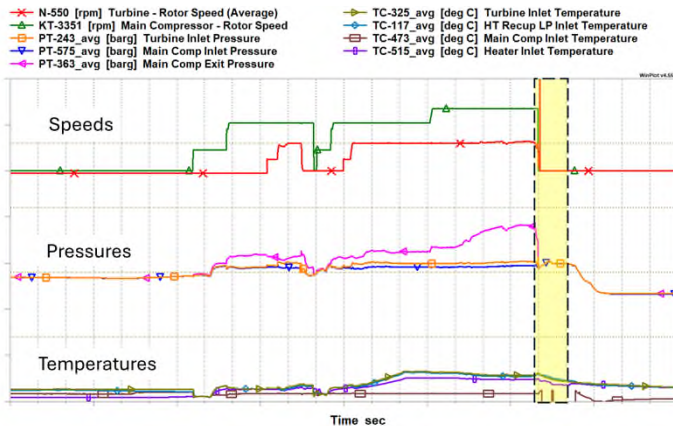

Operating conditions during Feb 8, 2024

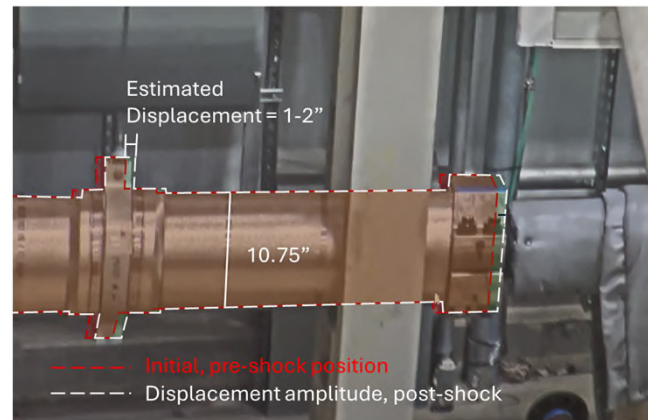

Video stills of displacement experienced during Feb 8, 2024

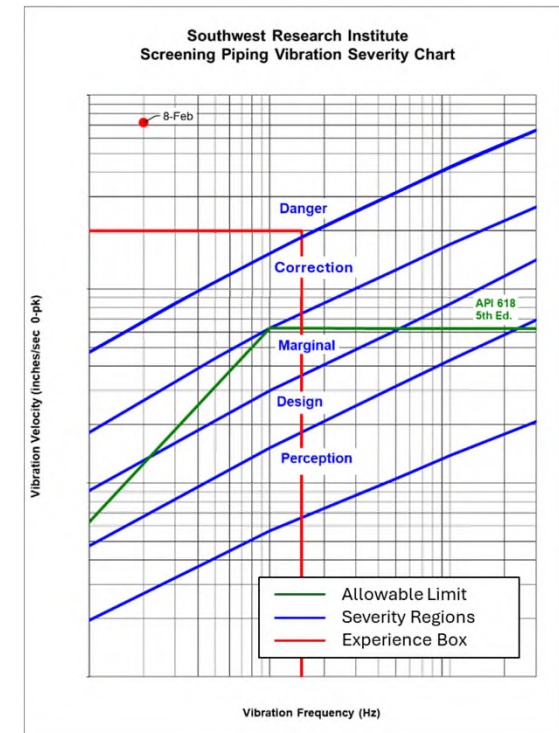

Assessed Severity of Hydraulic Shock Event on Feb 8, 2024

Hydraulic Shock Mitigation Modifications

- Modifications needed to reduce the vibration severity of future hydraulic shock events
- Implemented Solution: Bump Stops

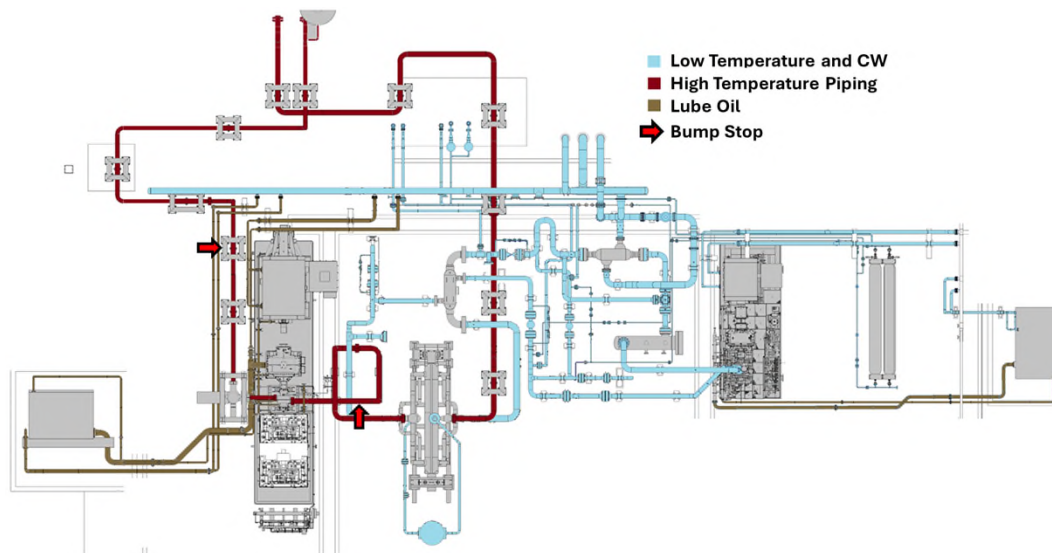

Bump Stop Locations in Piping System on Feb 8, 2024



Bump Stops

Hydraulic Shock Mitigation Analysis

- Design modifications were verified through test data model anchoring and simulations
 - Flownex SE utilized test data to validate model results and predict worst case scenarios
 - Dynamic CAESAR model with verified support stiffnesses used to determine bump stop locations

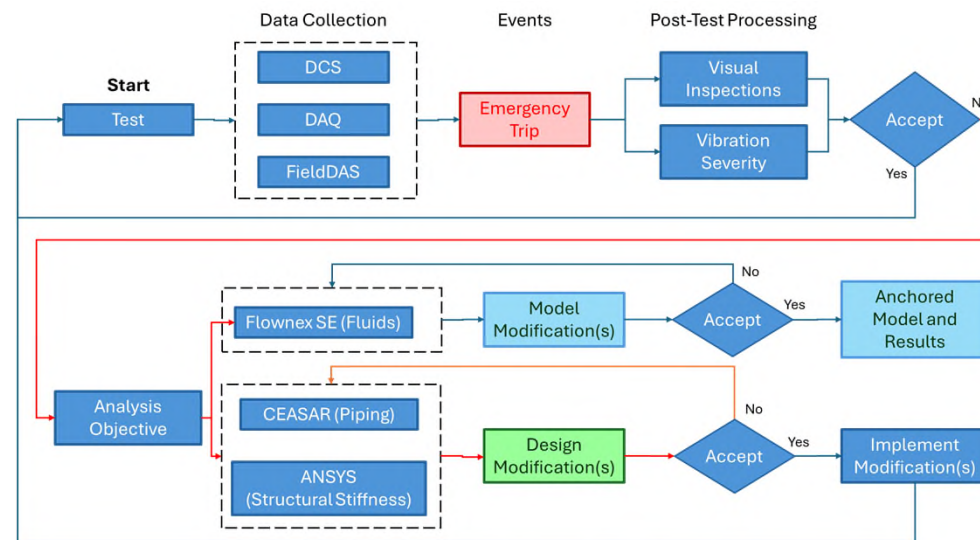

Flow diagram of actions taken to implement piping system modifications

Flownex SE Model Validation

- The Flownex SE dynamic model was used to assess the peak pressure experienced during the hydraulic shock
- Model results were comparable to the test data

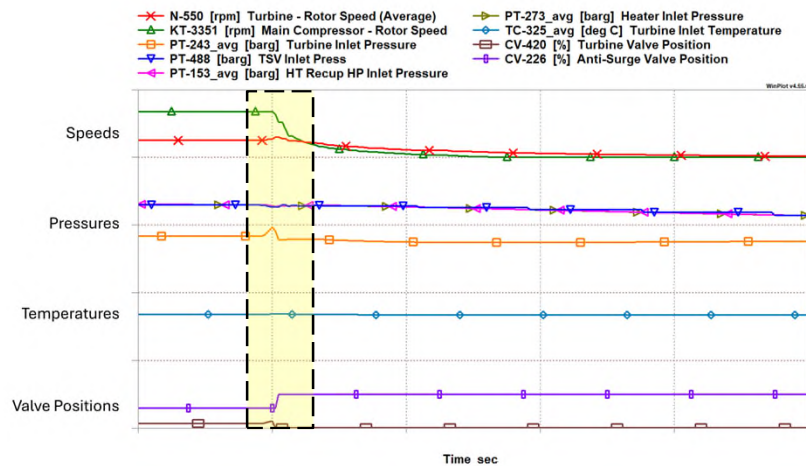

Feb 8 Hydraulic Shock Event: Test Data vs Model Results

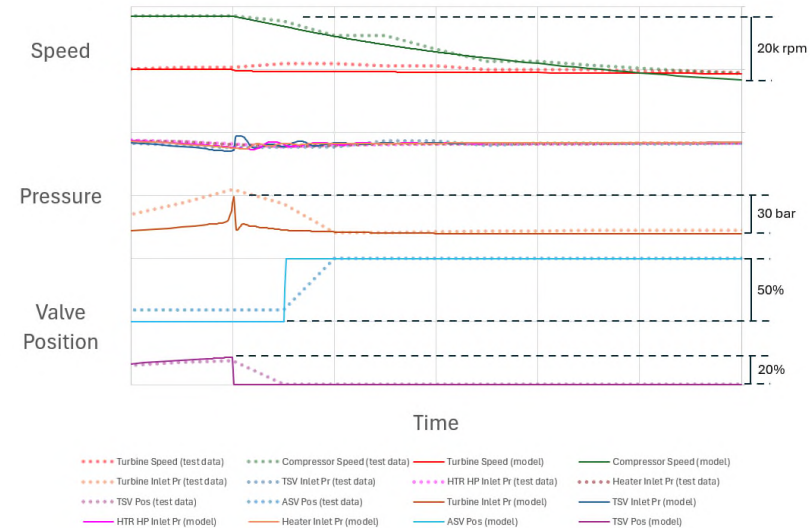

Worst Case Hydraulic Shock

- Worst Case Scenario:
 - Max Power operating conditions
 - Fast TSV closure time
- Analysis Conclusions:
 - Initial pressure spike magnitude correlates with a faster closure time, and is nonexistent at a closure time of 200 msec
 - However, the primary fluid hammer pressure wave is not significantly impacted by the fast closure time

Case	Description	Closure Time	Peak Press Increase
		sec	%
1	Max Conditions: Instantaneous Closure	0.002	10.4%
2	Max Conditions: Rated TSV Closure	0.200	9.5%
3	Max Conditions: Long Closure	1.940	0.0%
Test Data	Actual: Feb 8, 2024 Test Conditions	0.025	6.5%

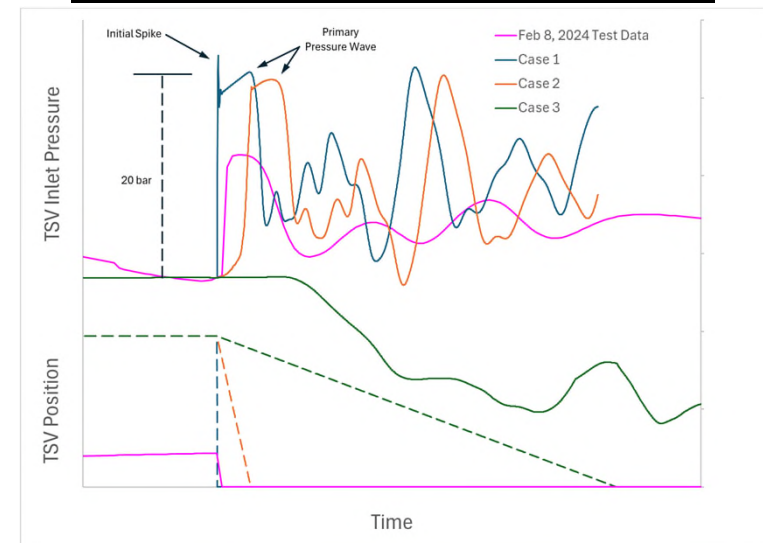

Dynamic Model Results of
TSV Closure Time vs. Peak Pressure Pulse

Dynamic CAESAR Analysis: Bump Stops

- Dynamic CAESAR model used to evaluate the force-displacement effects of the pressure pulse from the hydraulic shock
- Bump stops incorporated into the model at various locations
 - Bump stops need to allow thermal growth, while minimizing displacement to reduce equipment loads
- The final configuration did not meet all allowable loads, but approval of prior nozzle loads were obtained for similar values

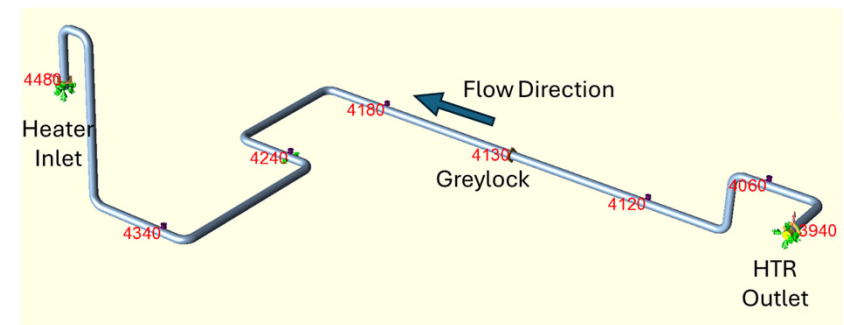
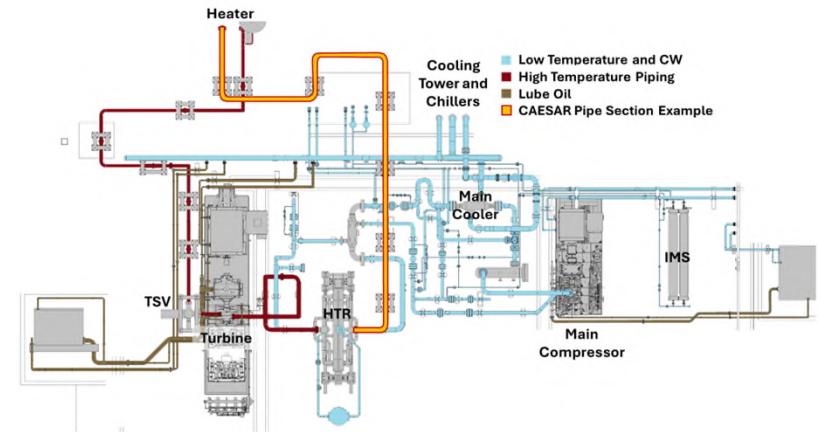

Case	Description	Highest Load-to-Allowable %			Comments
		HTR Out	Greylock	Heater In	
1	Baseline Condition: Feb 8, 2024	151%	161%	419%	
2	Bump Stop	83%	64%	300%	
3	2 Bump Stops, No Gap	53%	97%	114%	Bump Stop supports cannot withstand thermal growth
4	2 Bump Stops, Gap 50%	53%	90%	155%	
5	2 Bump Stops, Gap 75%	52%	88%	188%	As compliance gets larger, max load on Heater increases
6	Final Config: 2 Bump Stops, Gap 75%	57%	85%	137%	Updated Allowables, Approved for use

Supplemental Analysis.

ANSYS Structural Stiffness Verification

- CAESAR model was the primary tool to design the piping system
- The model needs to accurately predict loads and displacement, but simplifications can be made to reduce simulation run times
- Structural supports' stiffnesses as boundary conditions are typical examples
- To provide the most accurate structural stiffnesses, ANSYS models were performed to provide directional stiffnesses into the CAESAR model

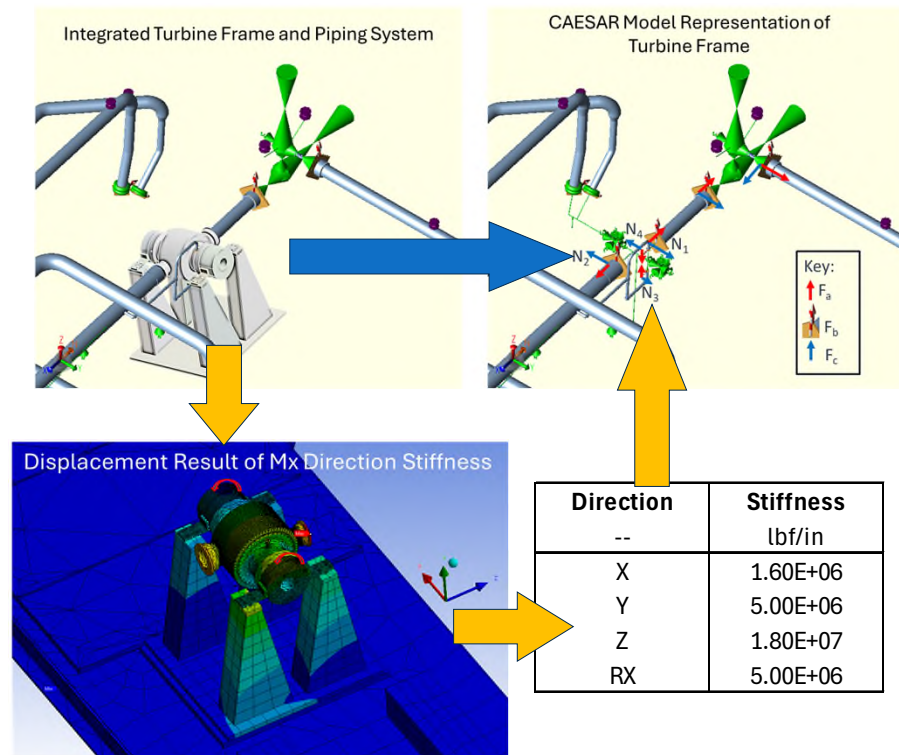

Example of ANSYS model results converted into CAESAR stiffness inputs

Final Bump Stop Configuration

- The dynamic CAESAR model evaluated all hot pipe sections
- In total, 3 new bump stops were installed
- All bump stops were welded to existing structures
 - ANSYS modeling was conducted to verify support stiffnesses used in the CAESAR model

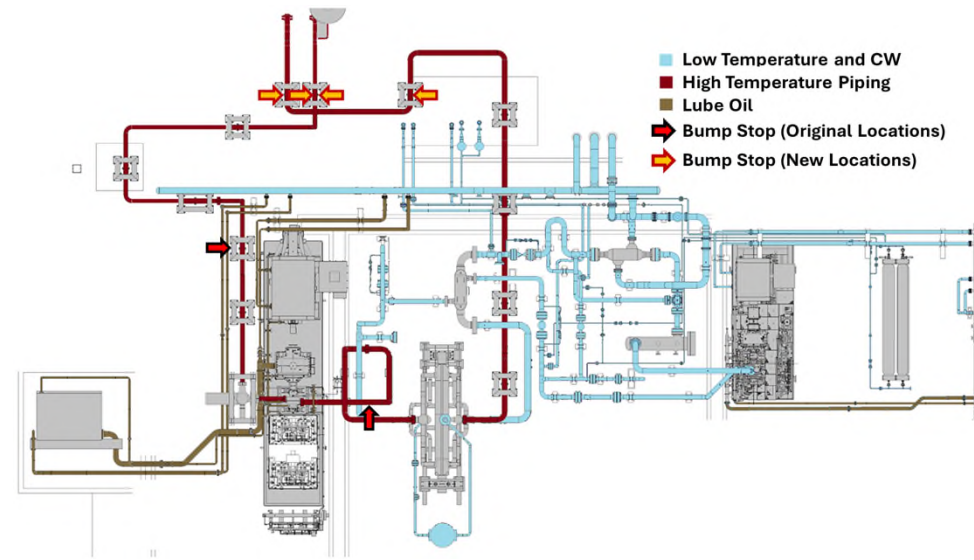

Emergency Shutdown: May 8, 2024

- May 8, 2024, Hydraulic Shock Event:
 - Turbine operating at high speed
 - Reduced vibration severity experienced even at higher operating speed and flows

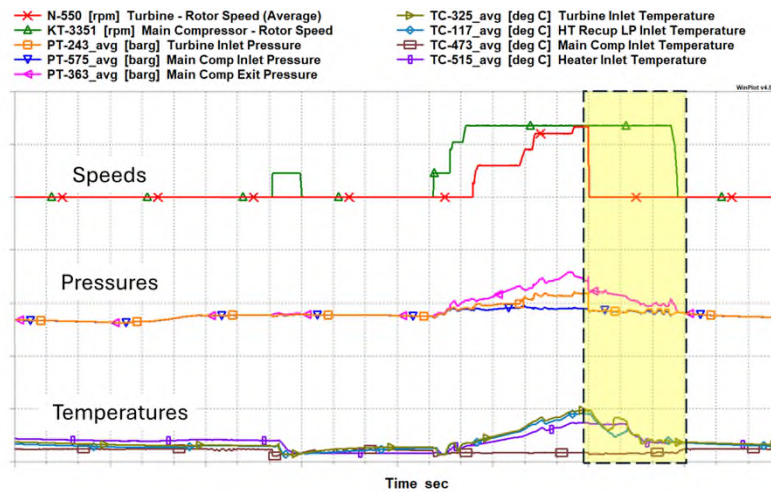

Operating conditions during May 8, 2024

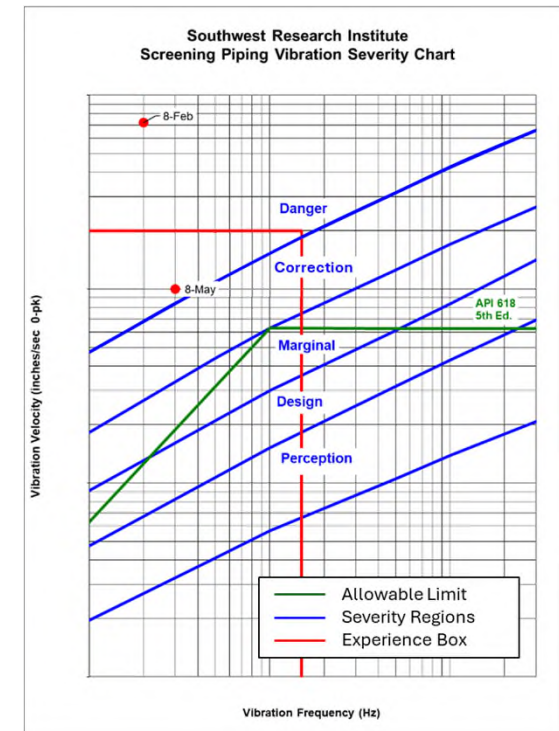

Assessed Severity of Hydraulic Shock Event on May 8, 2024

Dynamic CAESAR Analysis: Snubber Analysis

- During the hydraulic shock event on May 8, 2024, overall vibration levels were reduced
- Excessive levels were still experienced in specific local regions
- Snubbers were evaluated as design modifications
 - Snubbers are incorporated to modify the natural frequency of the pipe section, shifting away from the excitation domain

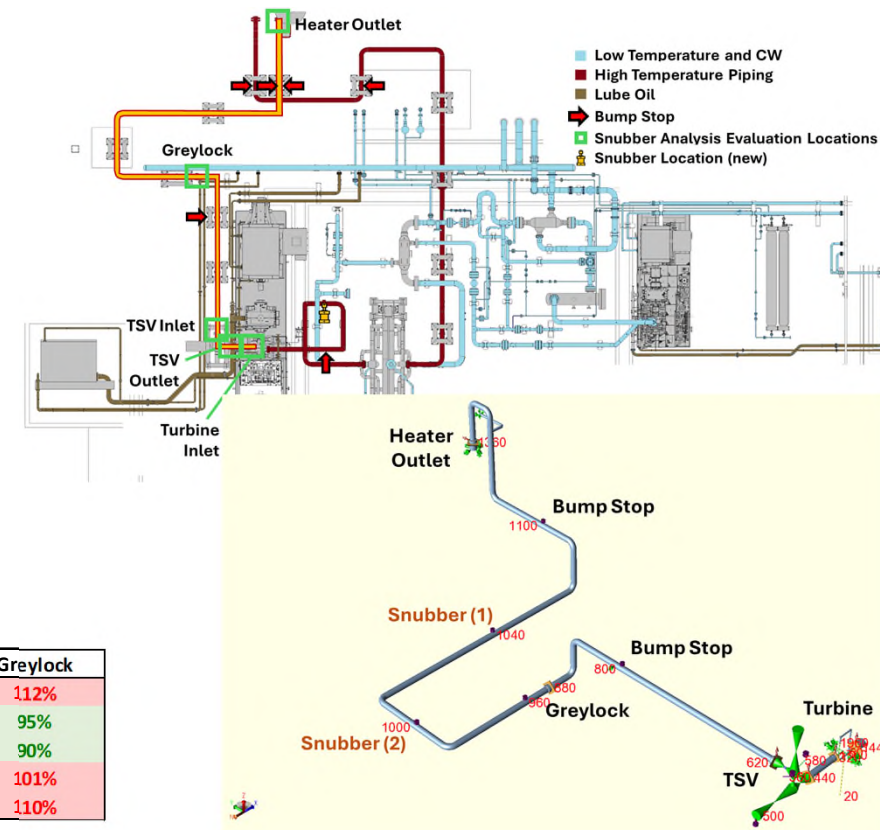

Case	Configuration	Highest Load-to-Allowable %				
		Heater Out	Turbine In	TSV Out	TSV In	Greylock
1	2 Bump Stops, No Snubber	148%	80%	100%	132%	112%
2	2 Bump Stops, 1 Snubber (1)	147%	192%	102%	139%	95%
3	2 Bump Stops, 1 Snubber (2)	149%	190%	85%	127%	90%
4	3 Bump Stops (TSV In), No Snubber	197%	64%	79%	96%	101%
5	3 Bump Stops (TSV Out), No Snubber	144%	51%	102%	117%	110%

* Configuration approved for installation

Final Piping Configuration

- The dynamic CAESAR model evaluated all hot pipe sections for additional snubber locations
- In total, 1 snubber was installed
 - Turbine-to-HTR pipe section

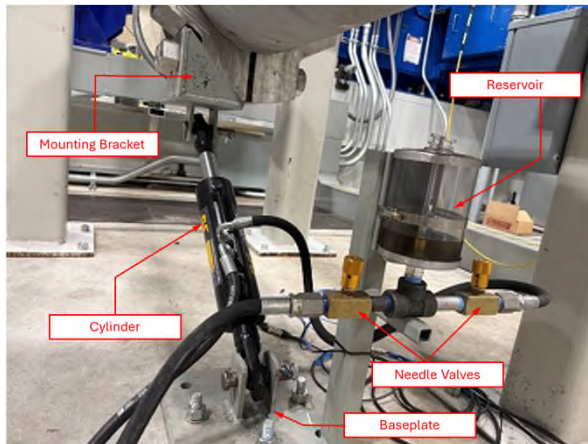
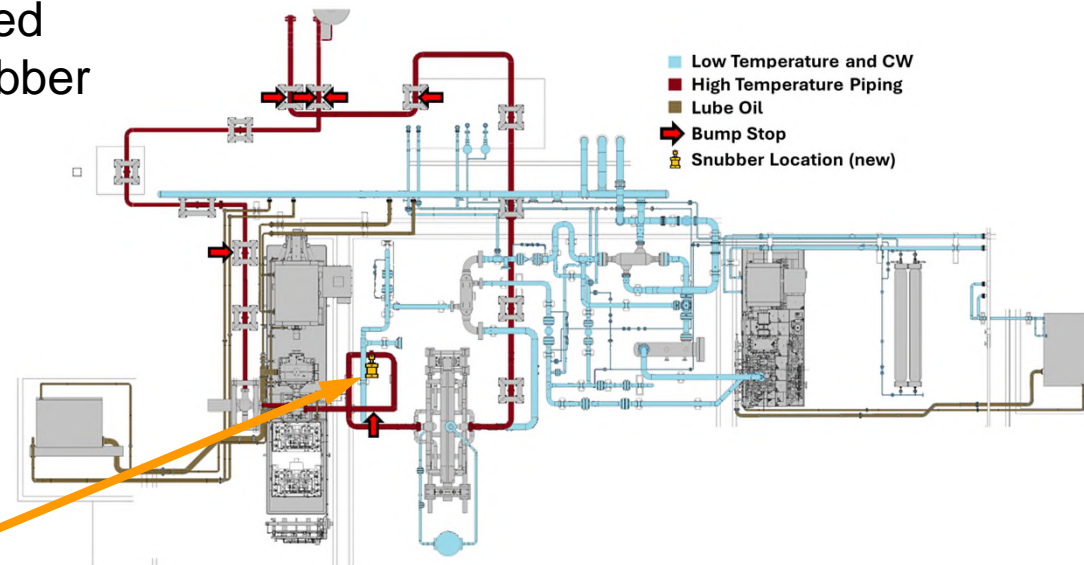

Snubber added to Turbine-to-HTR Pipe Section

Emergency Shutdown: Sept 27, 2024

- Sept 27, 2024, Hydraulic Shock Event: Planned Shutdown
 - Turbine operating at high speed
 - Overall vibration severity was within experience and greatly reduced from the first hydraulic shock in Feb 2024
 - Modifications implemented: additional bump stops and snubber installed

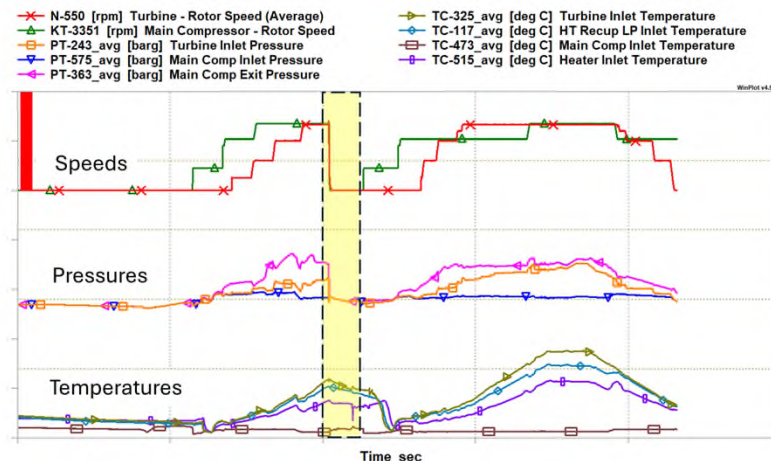

Operating conditions during Sept 27, 2024

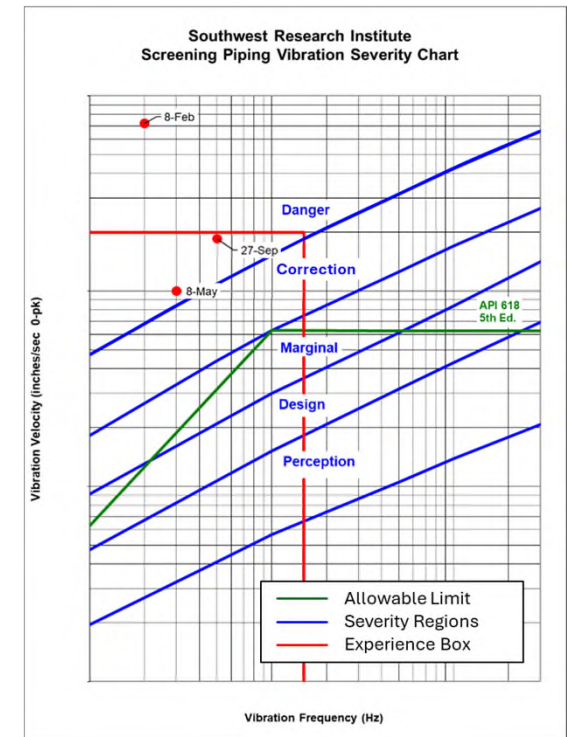

Assessed Severity of Hydraulic Shock Event on Sept 27, 2024

Conclusion

- Large variations in density and speed of sound for sCO₂ added levels of complexity in designing the piping system
- Initial design focused on thermal growth, equipment loads, system acoustics and Strouhal frequencies which helped defined potentially high vibration locations
- Three (3) hydraulic shock events occurred during Simple Cycle testing: Feb 8, May 8, and Sept 27, 2024
 - Feb 8, 2024: the first set of hydraulic shock data provided:
 - Flownex dynamic model validation data and assessment of a worst-case hydraulic shock event
 - Development of a dynamic CAESAR piping model, which informed modifications to mitigate vibration amplitudes
 - ANSYS structural models supplemented the dynamic CAESAR piping model by providing structural stiffness boundary conditions into the CAESAR model
 - May 8, 2024: overall reduced vibration amplitudes experienced due to the modifications
 - Installed one snubber to shift a pipe section's natural frequency from the excitation domain
 - Sept 27, 2024: vibration amplitudes were within the experience box
 - Reduced vibrations from February hydraulic shock, but increased vibrations from May testing



Gratefully Acknowledging the Support from U.S. DOE-NETL and Project Partners



www.STEPdemo.us



Questions?

Disclaimer

This report was prepared as an account of work sponsored by an agency of the United States Government. Neither the United States Government nor any agency thereof, nor any of their employees, makes any warranty, express or implied, or assumes any legal liability or responsibility for the accuracy, completeness, or usefulness of any information, apparatus, product, or process disclosed, or represents that its use would not infringe privately owned rights. Reference herein to any specific commercial product, process, or service by trade name, trademark, manufacturer, or otherwise does not necessarily constitute or imply its endorsement, recommendation, or favoring by the United States Government or any agency thereof. The views and opinions of authors expressed herein do not necessarily state or reflect those of the United States Government or any agency thereof.



Backup