



ECHOGEN

# Evaluation of Off-Design Performance of sCO<sub>2</sub> Pumped Thermal Energy Storage

Diana Jones  
*Echogen Power Systems*

# Objective

ECHOGEN

## The main objective of this work is...

To conduct comprehensive *off-design modeling* of a pumped thermal energy storage (PTES) system.

## Why is this important?

In evaluating the off-design performance of PTES systems, behavior generally deviates in one of the three ways: **power**, **reservoir balancing**, and **reservoir temperatures**.

## GOAL

To determine how off-design variations influence system performance and inform operating strategies.

# PTES Overview

- Relies on the transfer of heat into and out of thermal reservoirs
- Works by taking excess electricity from the grid to power a heat pump (charging, or CHG cycle)
- Later dispatched to the grid via a heat engine (generating, or GEN cycle)
- Geographical flexibility, relatively small ecological footprint, and the use of safe and readily available working fluids

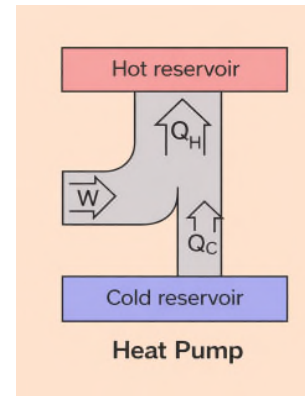

Heat pump cycle:  
Cold reservoir is the heat source  
Hot reservoir is the heat sink

$$COP = \frac{\dot{Q}_H}{W_{in}}$$

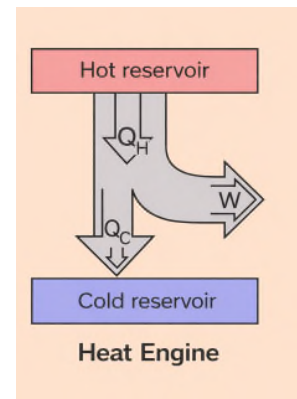

Heat engine cycle:  
Hot reservoir is the heat source  
Cold reservoir is the heat sink

$$\eta = \frac{W_{out}}{\dot{Q}_H}$$

# Project Description

Golden Valley Electric Association (GVEA)

Located in North Pole, Alaska - 1200 MWh-e plant

CHG cycle: 25 MW with 5:1 turndown

GEN cycle: 50 MW x 24 hrs with 10:1 turndown

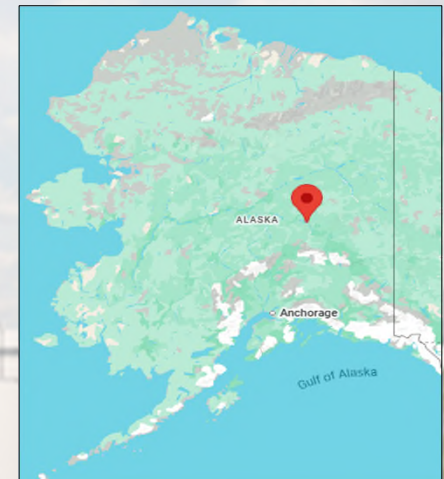

# CHG Cycle Configuration

## Three thermal reservoirs

- ❑ High-temperature thermal reservoir (HTR)  
→ High-grade heat sink
- ❑ Medium-temperature thermal reservoir (MTR)  
→ Medium-grade heat sink
- ❑ Low-temperature thermal reservoir (LTR)  
→ Low-grade heat source

## Five heat exchangers

- ❑ High-temperature heat exchanger (HTX)
- ❑ Medium-temperature heat exchanger (MTX)
- ❑ Low-temperature heat exchanger (LTX)
- ❑ Recuperating heat exchanger (RCX)
- ❑ Air-cooled heat exchanger (ACX - C)

## Two types of turbomachinery

- ❑ 3x33% compressors
- ❑ 1x33% and 1x67% turbines

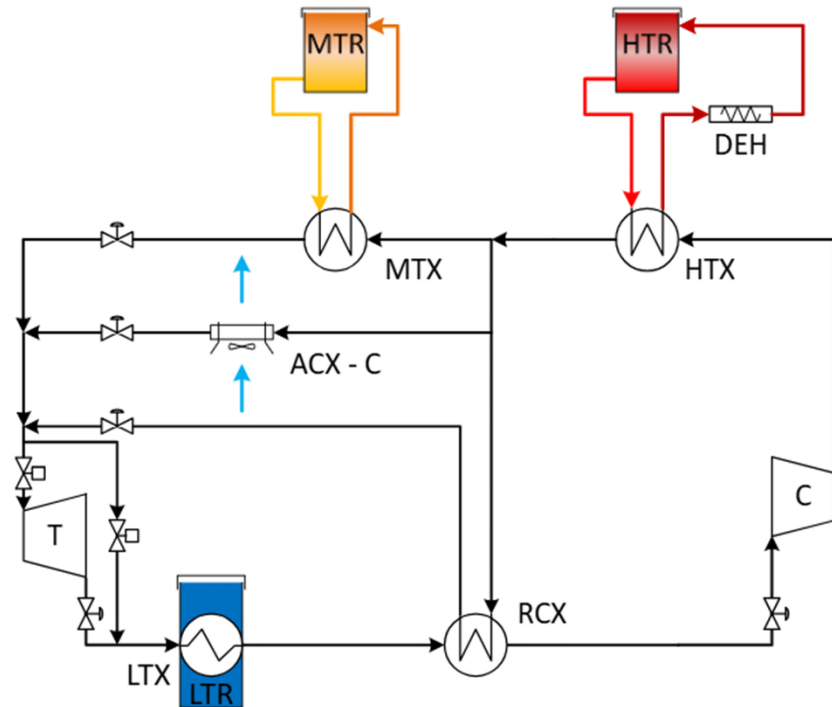

# GEN Cycle Configuration

## Three thermal reservoirs

- ❑ High-temperature thermal reservoir (HTR)  
→ High-grade heat source
- ❑ Medium-temperature thermal reservoir (MTR)  
→ Medium-grade heat source
- ❑ Low-temperature thermal reservoir (LTR)  
→ Low-grade heat sink

## Five heat exchangers

- ❑ High-temperature heat exchanger (HTX)
- ❑ Medium-temperature heat exchanger (MTX)
- ❑ Low-temperature heat exchanger (LTX)
- ❑ Recuperating heat exchanger (RCX)
- ❑ Air-cooled heat exchanger (ACX - G)

## Two types of turbomachinery

- ❑ 1x100% pump
- ❑ 1x100% turbine

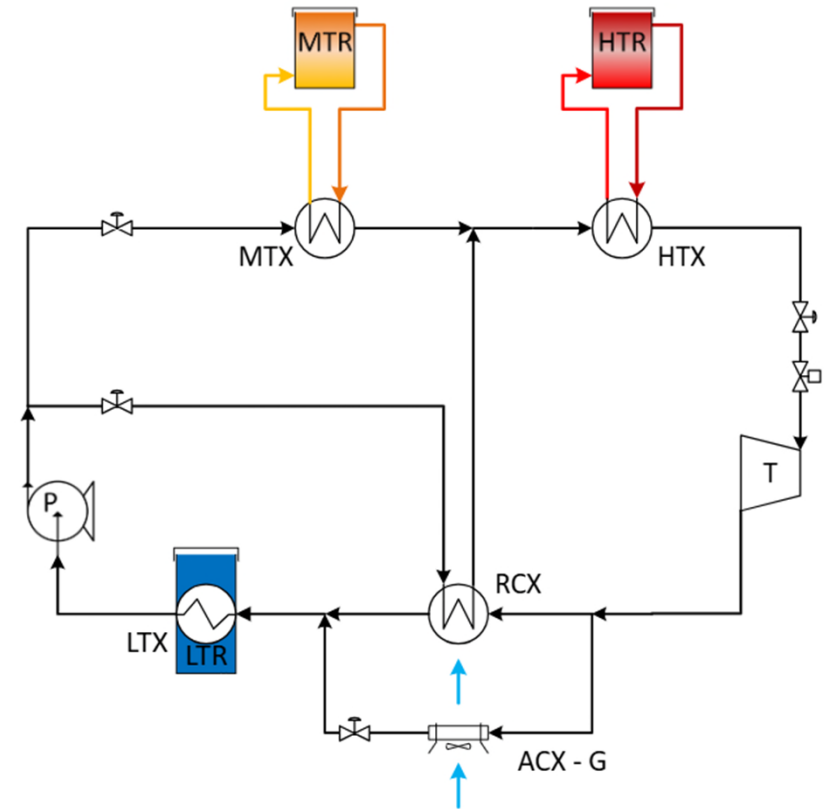

# Off-Design Modeling Studies: Turndown

**Parameter varied:** Net power into the cycle (W)

**Cycle:** CHG

**Range:** 25MW to 5MW (100 → 20%)

**Motivation:** Supply and demand from the grid fluctuate → PTES systems need to operate efficiently across wide range of loads and minimize performance losses



# Off-Design Modeling Studies: Thermal Balancing

**Parameters varied:** Thermal balancing ratios

**Cycle:** CHG and GEN

**Range:** Normalized range around design point value

**Motivation:** Determine flexibility in operating range because the reservoir balancing ratios may fluctuate due to off-design charging or thermally degraded reservoirs

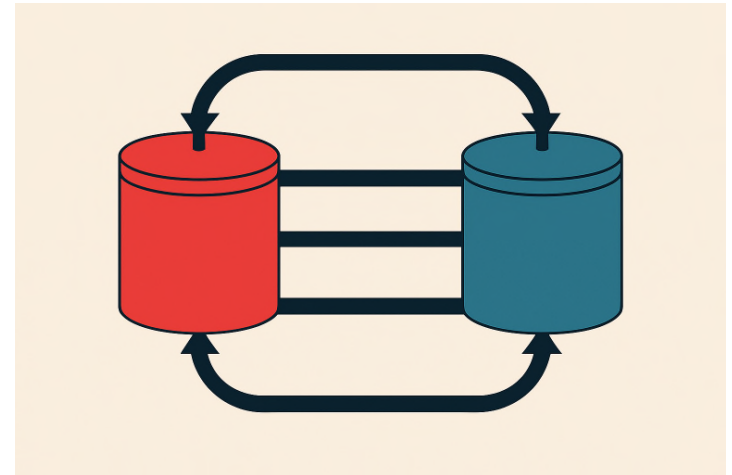

# Off-Design Modeling Studies: Thermal Degradation

**Parameters varied:** HTR hot temperature,  $T_h$

**Cycle:** GEN

**Range:** 70% to 100% normalized HTR temperature

**Motivation:** HTR may lose thermal energy (temperature) to the environment if it remains idle, and HTR  $T_h$  directly impacts turbine inlet temperature



# Turndown Strategy – CHG Cycle

*Primary turndown:*  
Use of variable inlet guide vanes  
(IGVs)

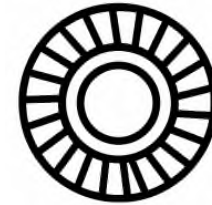

*Secondary turndown:*  
Use of IGVs with inlet throttling

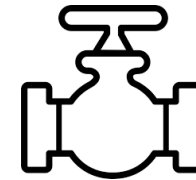

*Tertiary/Thermal turndown:*  
Use IGVs and direct electric heater  
(DEH)



# Primary Turndown

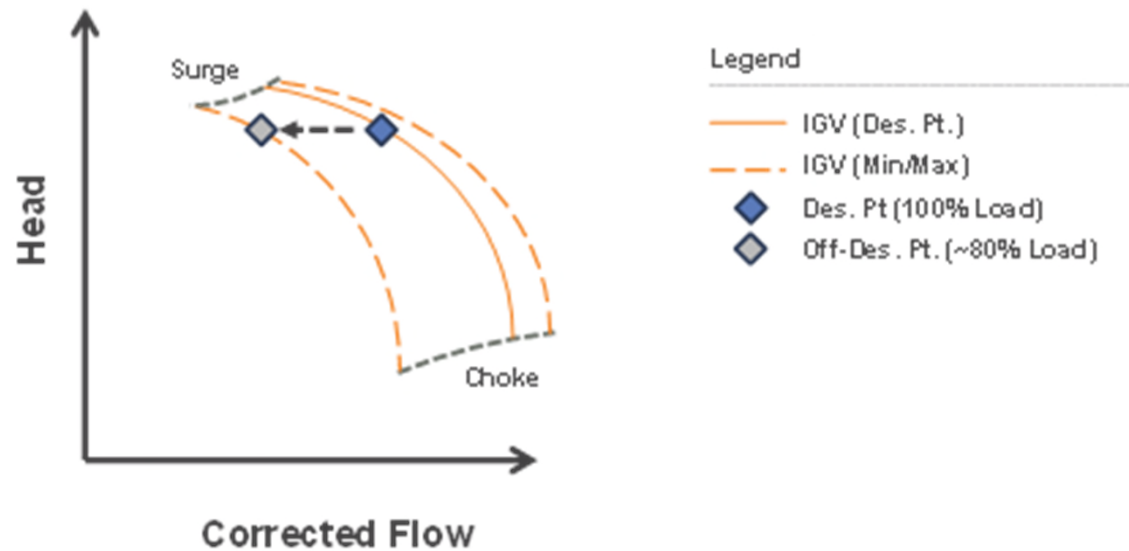

By decreasing the IGV angle to each the three compressors, the cycle can reduce volumetric flow to reduce overall power.

# Secondary Turndown

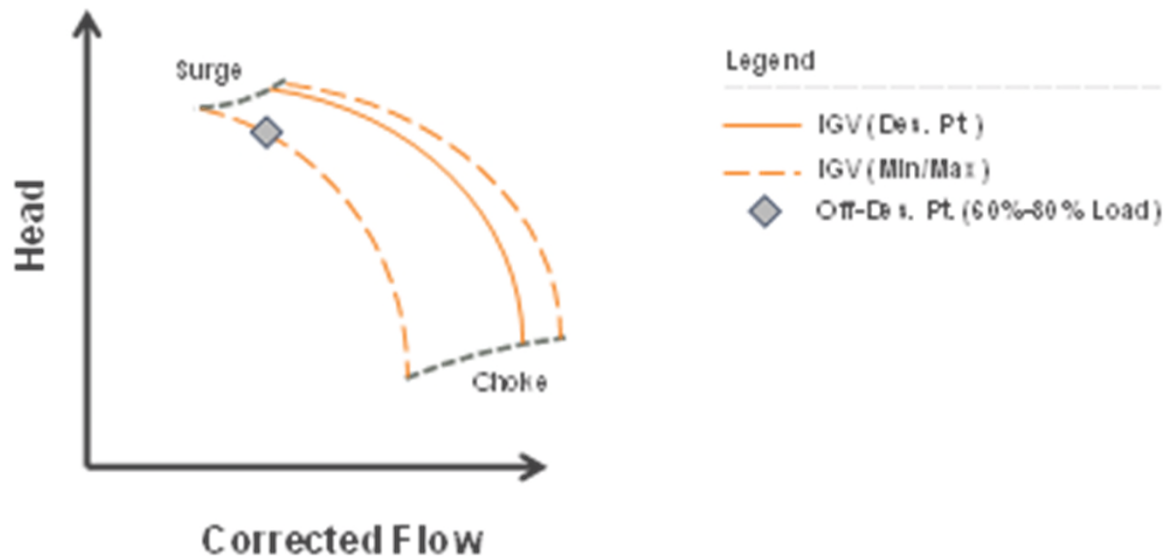

In addition to a minimum IGV angle (minimum volumetric flow), an inlet throttling valve can reduce pressure at this same operating point, thereby reducing inlet density and mass flow to reduce overall power.

# Tertiary/Thermal Turndown

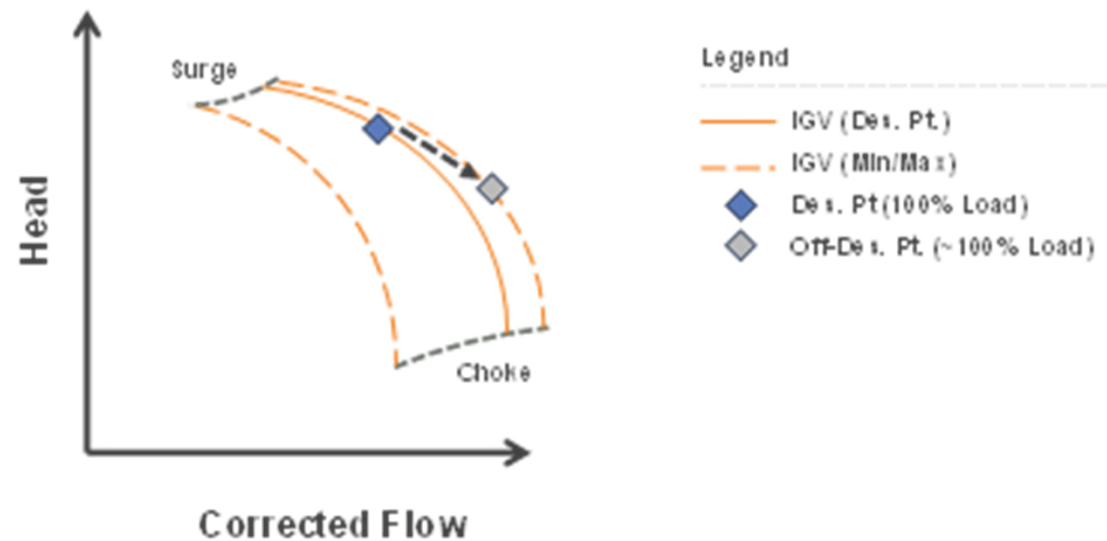

By increasing the IGV angle and directly heating the HTR with the DEH, the system can minimize performance losses incurred during primary and secondary turndown.

# Turndown Results

- ❑ Each segment corresponds to a varying number of compressors
  - ❑ Right → three compressors
  - ❑ Middle → two compressors
  - ❑ Left → one compressor
- ❑ The cycle can be effectively turned down across the full operating range, while maintaining minimal losses in COP
- ❑ We can maintain a smooth turndown curve

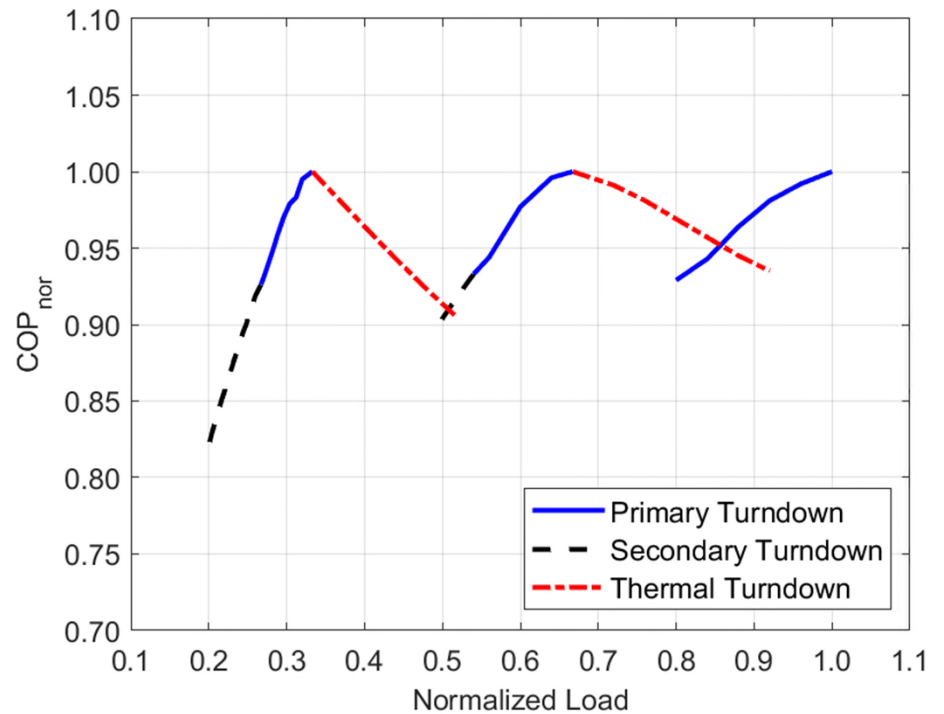

# Reservoir Balancing – CHG and GEN

The PTES system uses three thermal reservoirs to store and release heat to/from the sCO<sub>2</sub> via the heat exchangers.

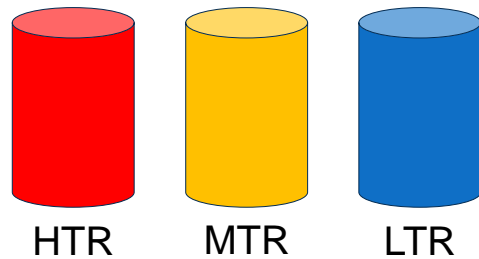

Each reservoir corresponds to a design duty value ( $\dot{Q}$ ), which is the amount of heat transferred to and from the heat exchanger to the thermal reservoir.

These duties are tied together via thermal balancing ratios to maintain alignment.

$$\Psi_{m-mh} = \frac{\dot{Q}_{MTR}}{\dot{Q}_{MTR} + \dot{Q}_{HTR}} \quad \Psi_{h-c} = \frac{\dot{Q}_{HTR}}{\dot{Q}_{LTR}}$$

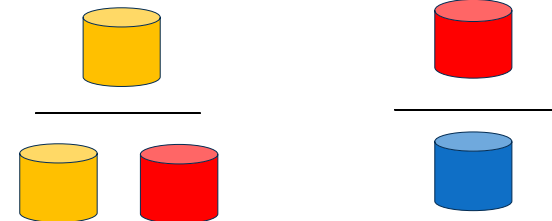

# Reservoir Balancing Results - CHG

- ❑ In the CHG cycle, the COP tends to rise as the two ratios are increased.
- ❑ A heat pump will perform better with a larger high-temperature duty relative to low-temperature duty.
- ❑ Overall, we can cover a large operating range in either direction for both ratios, ensuring operation flexibility.

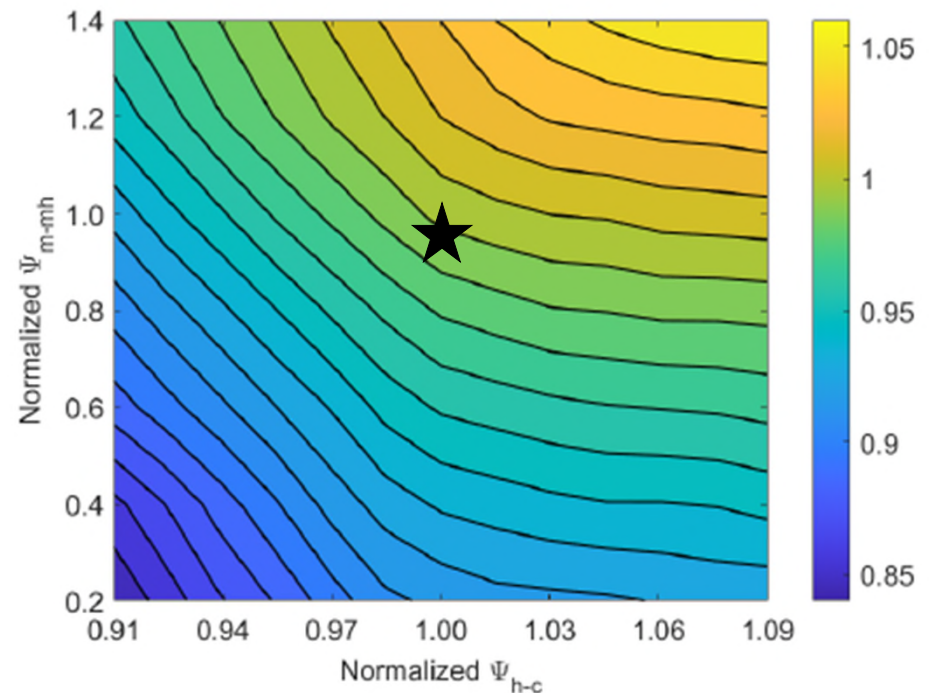

# Reservoir Balancing Results - GEN

- ❑ The CHG and GEN cycles trend in opposite directions, but thermodynamically this makes sense.
- ❑ Important takeaway is that we can cover a large operating range in the GEN cycle.
- ❑ If we have a mismatch in thermal capacities of the reservoir, we have the ability to manipulate the thermal balancing ratio to re-align the reservoirs.

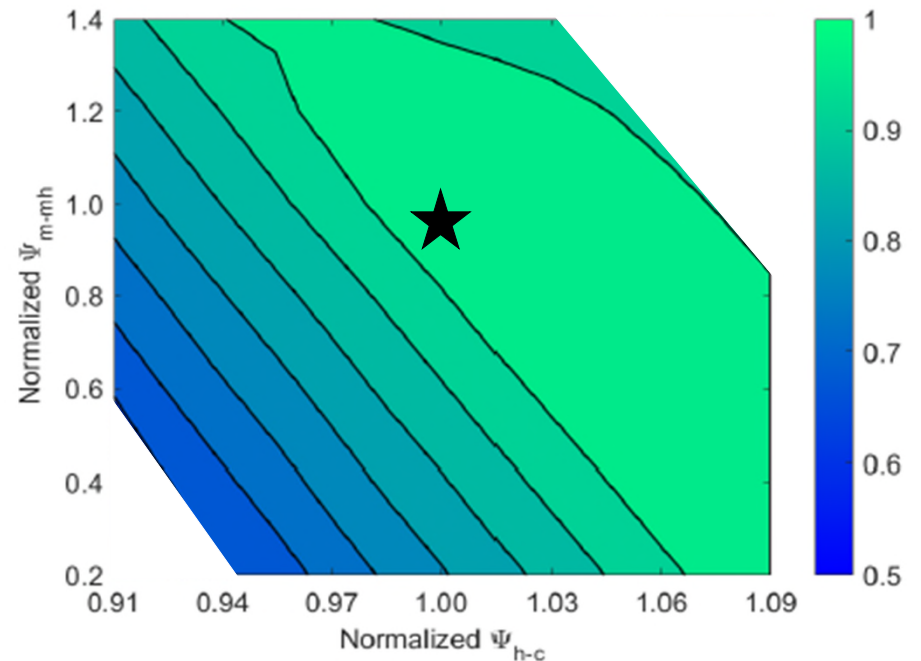

# Thermal Degradation Strategy - GEN

## GVEA requirement:

GEN cycle must maintain design power with loss of 20°C in HTR  $T_h$ , which corresponds to ~10% of its total stored enthalpy.

The original design point could not meet this requirement, so a new design point has been established.

Original Design Point → *Baseline*

New Design Point → *Alternative*

### Baseline

- Maintain 50MW output
- High-side cycle pressure capped
- Centered around design HTR temperature

### Alternative

- Maintain 50MW output
- High-side pressure limit released
- Centered around lowered HTR temperature

# Turbine Work

$$W_{turbine} = \dot{m}\Delta h = \dot{m}(h_{in} - h_{out})$$

$$h_i = h(T_{in}, P_{in})$$

$$W_{turbine} = \dot{m}(h_{in}(T_{in}, P_{in}) - h_{out})$$

$$T_{in} \downarrow \quad \dot{m} \uparrow \quad P_{in} \uparrow$$

# Thermal Degradation Results

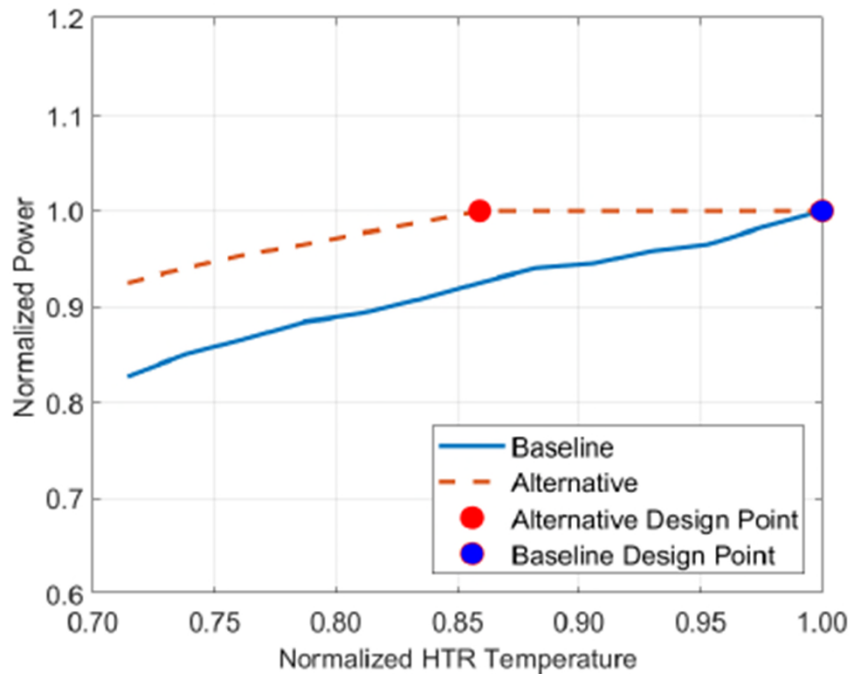

As you can see, the *Baseline* case falls off immediately.

Because the *Alternative* case is centered around the lower HTR temperature, it can maintain the rated power.

$$W_{turbine} = \dot{m}\Delta h = \dot{m}(h_{in} - h_{out})$$

$$h_i = h(T_{in}, P_{in})$$

# Thermal Degradation Results

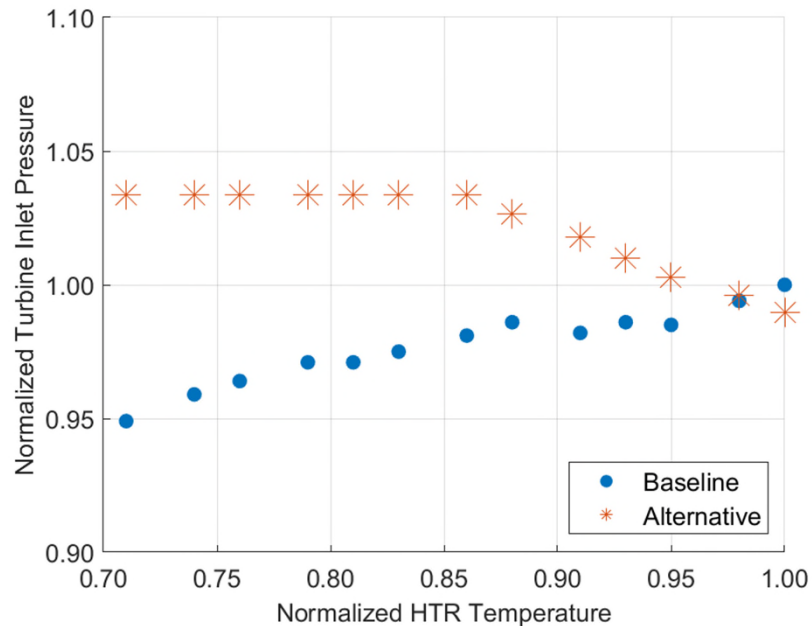

High-side pressure is able to increase, compensating for the loss in enthalpy due to temperature loss.

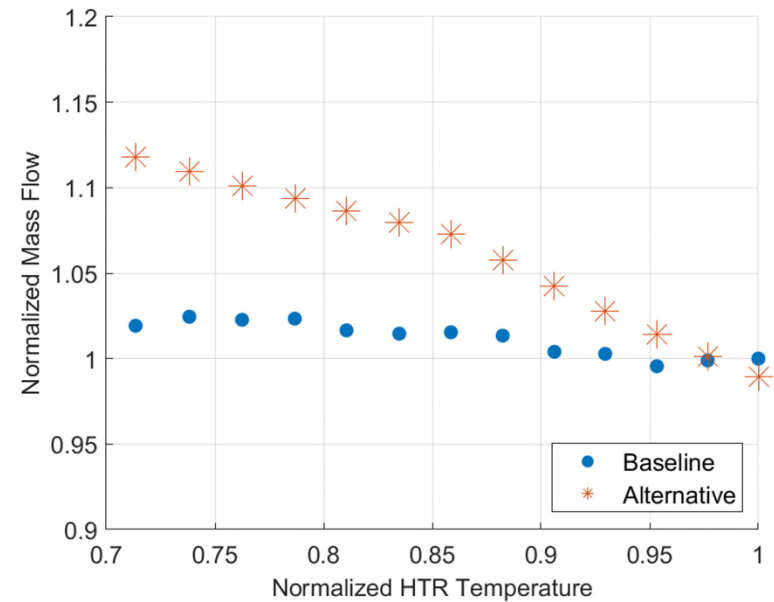

Mass flow also increases with an increase in pressure, further compensating for the losses incurred from thermal degradation.

# Thermal Degradation Results

Both cases have a similar efficiency curve, and the *Alternative* case can maintain power at the lower HTR temperature, making it a strong design point to carry forward with.

## Takeaway:

The cycle can maintain design power under varying degrees of HTR temperature loss, showcasing the resiliency of the PTES system.

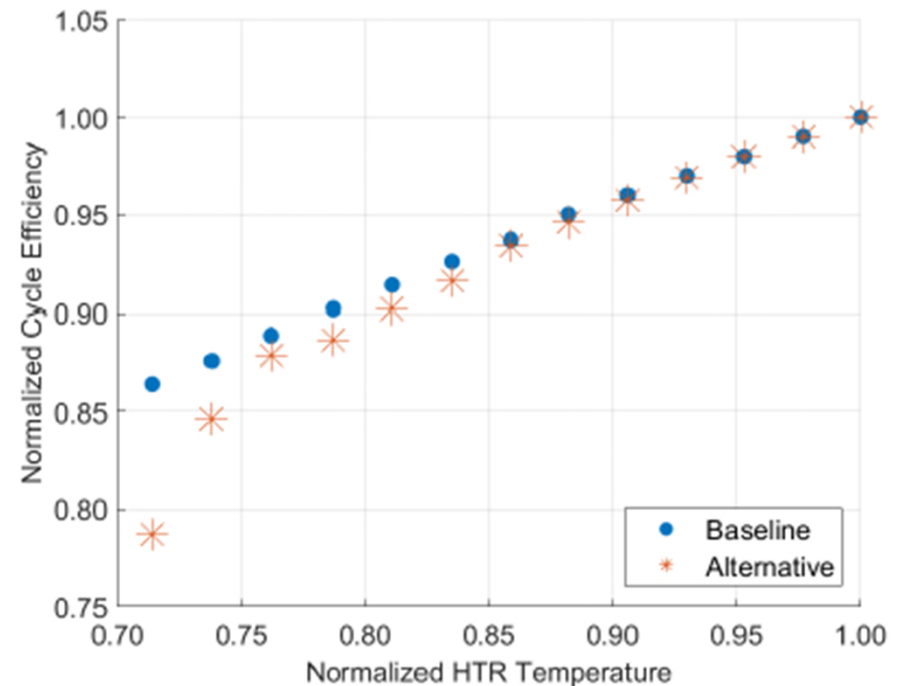

# Conclusions

---

## Turndown:

The CHG cycle can cover its full operating range, with minimal losses in performance, creating a smooth turndown curve.

---

## Thermal balancing:

In both CHG and GEN cycles, the system can operate over a wide range of thermal balancing ratios, allowing the PTES system to recover from mismatched thermal reservoir capacities.

---

## Thermal degradation:

An alternative design point has been established that enables the GEN cycle to maintain rated power even under thermal degradation, making the cycle resilient to external heat loss.

# Questions?

# ECHOGEN

Contact Information:

Diana Jones, Systems Engineer  
echogen.com  
E-mail: [djones@echogen.com](mailto:djones@echogen.com)



# Acknowledgements

The information, data, or work presented herein was funded in part by the U.S. Department of Energy, award numbers:

DE-AR0000996 Advanced Research Projects Agency - Energy

DE-CD0000033 Office of Clean Energy Demonstrations

DE-EE0008997 Office of Energy Efficiency and Renewable Energy

DE-EE0009814 Office of Energy Efficiency and Renewable Energy

DE-EE0011192 Office of Energy Efficiency and Renewable Energy

This report was prepared as an account of work sponsored by an agency of the United States Government. Neither the United States Government nor any agency thereof, nor any of their employees, makes any warranty, express or implied, or assumes any legal liability or responsibility for the accuracy, completeness, or usefulness of any information, apparatus, product, or process disclosed, or represents that its use would not infringe privately owned rights. Reference herein to any specific commercial product, process, or service by trade name, trademark, manufacturer, or otherwise does not necessarily constitute or imply its endorsement, recommendation, or favoring by the United States Government or any agency thereof. The views and opinions of authors expressed herein do not necessarily state or reflect those of the United States Government or any agency thereof.

$$W = \dot{m}\Delta h = \dot{m}c_p\Delta T = \dot{m}c_pT_i(PR^{(\gamma-1)/\gamma} - 1)$$