



Proof-of-Concept Demonstration of a Closed-Loop CO₂ Power Cycle for Spherical Tokamak Fusion Power Plant

Dhinesh Thanganadar
UK Industrial Fusion Solutions
Ltd, Culham Campus, Abingdon,
Oxfordshire, United Kingdom

Jacob Connors
UK Atomic Energy Authority
Culham Science Centre,
Abingdon, Oxfordshire, United
Kingdom

Jack Acres
UK Industrial Fusion Solutions
Ltd, Culham Campus, Abingdon,
Oxfordshire, United Kingdom

	Dhinesh Thanganadar, Ph.D., is the Advanced Cycles Lead at UK Industrial Fusion Solutions Ltd, a subsidiary of the UK Atomic Energy Authority. He leads the design of power cycles for fusion power plant, bringing over 16 years of experience across coal-fired, combined cycle, and pioneering concentrating solar thermal power technologies.
	Jacob Connors is a Process Engineer at UK Atomic Energy Authority.
	Jack Acres is the Head of Engineering - Power and Cooling for UKIFS, in Abingdon, United Kingdom. Jack's focus is on developing power generation elements of fusion. This has involved understanding how the STEP prototype can convert thermal energy from a novel tokamak into electrical power.

ABSTRACT

UK Industrial Fusion Solutions Ltd (UKIFS) is developing the Spherical Tokamak for Energy Production (STEP), with the objective of delivering a STEP Prototypic Powerplant (SPP) by 2040. The tokamak's in-vessel components are subject to diverse thermal loads arising from surface heat fluxes, volumetric neutronic heating, and material limitations, necessitating multiple cooling loops operating at distinct temperature levels. To streamline system integration, the SPP consolidates these heat streams into three temperature grades: low (150–250 °C), medium (250–450 °C), and high (>450 °C), all supplying a single CO₂ power cycle. This multi-grade heat integration concept offers improved compactness and efficiency but has yet to be experimentally validated, particularly under relevant off-design and dynamic operating conditions. Fusion power

cycles must also accommodate the inherently pulsed operation of tokamaks, where alternating “pulse” and “dwell” phases induce significant heat input fluctuations. Sustaining turbine operation during dwell periods is essential to mitigate thermal cycling and mechanical fatigue. Accordingly, a fast-ramping system and an auxiliary heat source are integrated into the CO₂ cycle, enabling two steady-state operating modes, fusion and auxiliary heating, and rapid switching between them to maintain continuous operation. To verify this approach, UKIFS is constructing a ~200 kWe proof-of-concept (PoC) test rig to experimentally evaluate cycle operability, controllability, and mode-transition under realistic transient conditions. The PoC will demonstrate the feasibility of stable power generation during pulsed operation and provide critical validation data for future scale-up.

1. INTRODUCTION

The UK Industrial Fusion Solutions Ltd (UKIFS) is developing the Spherical Tokamak for Energy Production (STEP) with the aim of demonstrating a prototypical fusion power plant (SPP) capable of delivering approximately 100 MWe of net electrical power to the grid by the 2040s [1]. Realising this objective requires a power conversion system that combines high thermodynamic efficiency, effective integration of multi-temperature heat streams, operational flexibility under transient conditions, and scalability to gigawatt-class infrastructure [2].

Designing a heat-to-electricity cycle for a fusion environment presents several competing requirements:

1. High conversion efficiency to offset the significant parasitic power consumption of the tokamak and its auxiliary systems.
2. Multi-grade heat integration to accommodate heterogeneous heat streams from in-vessel components (IVCs) operating at different temperatures.
3. High transient flexibility, characterised by rapid ramp-rate capability, and wide turndown ratios, as plasma ramps in minutes.
4. Compatibility with intermittent heat input, as early-generation tokamaks operate in pulsed mode, alternating between “pulse” and “dwell” phases.
5. Large-scale, reliability, demanding a compact, robust, and commercially viable system architecture capable of sustained high availability.

Although these requirements share similarities with those of advanced thermal plants operating in high-renewable grids, such as load flexibility and fast ramping, their combined severity is unprecedented in a fusion context. In particular, the challenges of multi-grade heat integration and operation under pulsed heat input represent significant departures from conventional practice.

Fusion power systems further complicate plant design through their unique thermal environment. IVCs are subjected to high surface heat fluxes, volumetric neutron heating, and material

temperature limits, resulting in multiple coolant circuits at distinct temperature levels [3,4]. For the SPP, these are consolidated into three representative temperature grades: low (150–250 °C), medium (250–450 °C), and high (>450 °C), all supplying heat to a single transcritical CO₂ Brayton cycle. This multi-grade integration strategy provides a simple and efficient layout. IVC coolant selection is influenced not only by heat removal capacity but also by neutron transparency for tritium breeding, resistance to radiolysis, corrosion behaviour, tritium transport and removal, and resilience to loss-of-coolant events [5].

Inductive fusion power plants typically operate in cyclic modes, alternating between energy-producing “pulse” phases and low-power “dwell” periods. During dwell phases, thermal input to the power cycle diminishes sharply or ceases altogether. Maintaining continuous turbomachinery operation through these intervals is vital for plant availability and turbine longevity. Frequent start–stop cycles, as observed in conventional thermal units under flexible operation, impose significant low-cycle fatigue stresses that degrade reliability, increase maintenance demands, and compromise economic performance. Thus, fusion power cycles have to sustain stable turbine operation through transient and intermittent conditions to ensure consistent power delivery to the grid. Spherical tokamaks, such as STEP, have fewer constraints and may achieve even longer pulse durations, the initial prototypic operation of STEP is expected to be pulsed.

Experience from large thermal plants offers useful benchmarks. Conventional coal-fired units achieve ramp rates of roughly 6 % load/min, while advanced supercritical and combined-cycle units may reach 8 % load/min, and 11 % load/min, respectively [6]. In comparison, fusion plasmas ramp within only a few minutes: ITER targets 5–50 minute pulses [7], EU-DEMO envisions 2-hour pulses with 10-minute dwells [8]. Plasma start-up can be very rapid, and shutdowns can occur suddenly, whether planned or unplanned [9], in the order of 100 secs [4,10] for EU-DEMO.

In conventional power plant engineering, the need for operational flexibility has been widely studied under scenarios of high renewable penetration, where parameters such as minimum stable load, ramp-rate capability, and start/stop frequency define performance limits. For fusion applications, similar analyses must be extended to cycles operating under multi-grade heat inputs and fusion relevant transient conditions.

The thermodynamic efficiency of steam Rankine cycles is constrained when integrating relatively large heat duty share from LT heat sources [11]. While the supercritical CO₂ (sCO₂) Brayton cycle surpasses the Rankine cycle above ~550 °C for single heat sources [12], its behaviour under multi-source conditions remains uncertain. sCO₂ technology offers several advantages: high efficiency, compact turbomachinery (an order of magnitude smaller [13]), and low thermal inertia heat exchangers signifying fast dynamic response [14,15]. But its current technology readiness level (TRL ≈ 3) indicates early-stage development. Ongoing large-scale projects, such as the Supercritical Transformational Electric Power (STEP- USA) Demonstration, aim to advance TRL to 7 at 10 MWe capacity [16]. At present, the TRL of the CO₂ cycle at the SPP scale is low to medium, reflecting ongoing development and raising potential reliability concerns. [17,18].

In the fusion domain, several conceptual fusion studies [19–21] have explored hybrid power cycles incorporating fusion-independent heat sources (FIHS), such as thermal storage, electric heaters, or clean-fuel boilers with carbon capture, to sustain turbine operation during dwell phases. The adoption of the sCO₂ cycle also enables coupling with direct-fired oxy-combustion system for direct heat injection to the cycle. Despite these advances, no experimental demonstration to date has validated a CO₂ cycle capable of rapid ramping, continuous operation under intermittent heat input, and smooth transition between auxiliary and fusion thermal heating modes at relevant conditions.

To address this critical research gap, UKIFS is developing a 200 kWe proof-of-concept (PoC) test rig to experimentally assess the operability, controllability, dynamic response, and mode-transition characteristics of an sCO₂ power cycle integrated with auxiliary heating and fast response thermal energy storage technology. This work represents a key step toward enabling continuous, flexible power conversion in future fusion energy systems.

2. Illustrative SPP Full Scale Design

The total thermal power from the tokamak is [9],

$$P_{therm} = P_{fus} + P_{aux} + P_{neutron\ interaction}$$

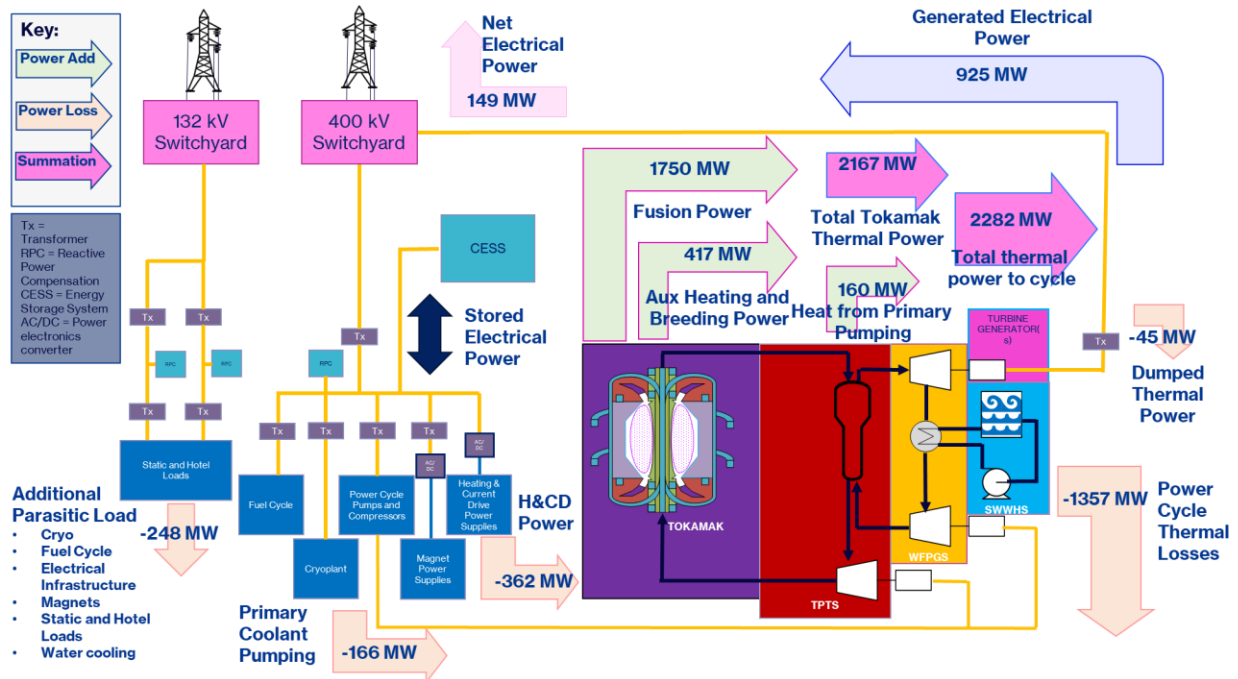

Figure 1 Power infrastructure conceptual architecture, showing net power flow [2]

The SPP fusion power (P_{fus}) is given as 1750 MW_{th} [22]. The combined thermal contribution from neutron interactions within the breeding blanket ($P_{neutron\ interaction}$) and heating and current drive systems (P_{aux}) amounts to 417 MW_{th}, giving a total tokamak thermal power of 2167 MW_{th}. A small

fraction of this heat is delivered at temperatures too low to integrate and hence rejected, resulting in a total of about 2117 MW_{th} integrated with the power cycle, as illustrated in Figure 1.

Table 1 Tokamak Boundary Conditions

Parameters	Coolant	IVC	Heat Split (%)	Supply Temperature (°C)	Return Temperature (°C)
HT Heat Source	Helium	Blanket, Outboard first wall	65	600	400
MT#1 Heat Source	Helium	Outboard limiter	10	450	250
MT#2 Heat Source	Helium	Divertor cassette	5	500	350
LT Heat Source	D ₂ O	Divertor and inboard components	20	213	200

Thermodynamic simulations were performed using Aspen Plus[®], with REFPROP[®] employed to determine the thermophysical properties of CO₂, helium, and heavy water [23]. The modelling assumptions and boundary conditions are listed in Table 1 and Table 2. A simple recuperative recompression CO₂ cycle was selected as the baseline configuration and subsequently modified to accommodate multiple heat sources at appropriate temperature intervals.

Table 2 Thermodynamic Modelling Assumptions [11,23]

Parameters	Unit	Values
Turbine isentropic efficiency	%	90
Compressor isentropic efficiency (CO ₂ / He)	%	85
CO ₂ pump isentropic efficiency	%	85
Generator efficiency	%	98.4
Pump isentropic efficiency (H ₂ O/ D ₂ O)	%	75
Pump motor efficiency	%	96

The LT heat source was integrated downstream of the low-temperature recuperator (LTR), while the MT heat sources were introduced in parallel with the high-temperature recuperator (HTR). The HT heat was supplied upstream of the HT turbine. For the LT source, the return temperature is 200 °C (Table 2); thus, it can be integrated either in parallel with or downstream of the LTR [24]. Under the boundary conditions considered, the latter configuration was preferred, as the small LT temperature differential ($\Delta T_{LT} = 13$ °C) requires a higher CO₂ mass flow rate for heat transfer, despite the associated increase in pressure drop.

The MT heat sources, with return temperatures exceeding 250 °C, were integrated in parallel with the HTR, where the CO₂ temperature exiting the LT source cold stream is below 213 °C. The mass flow rate among the various splits was optimised to minimise exergy destruction across the heat exchanger. A recompressor was included in parallel with the LT heat integration to enhance cycle efficiency.

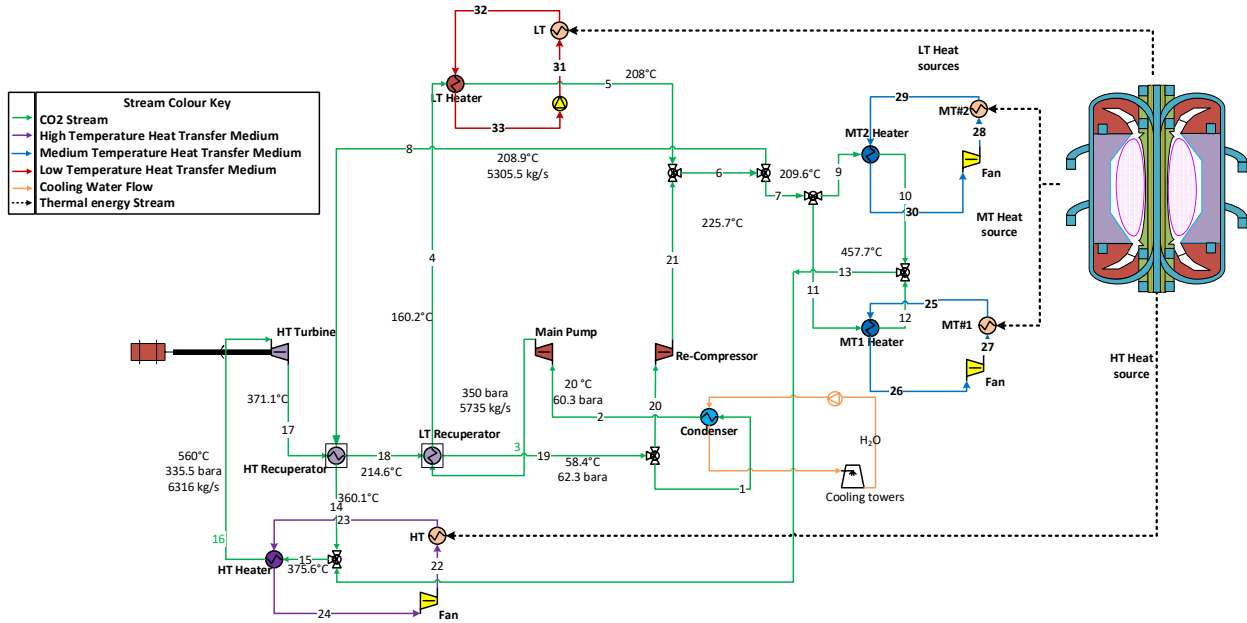

Figure 2 Transcritical Recompression CO₂ Cycle Configuration

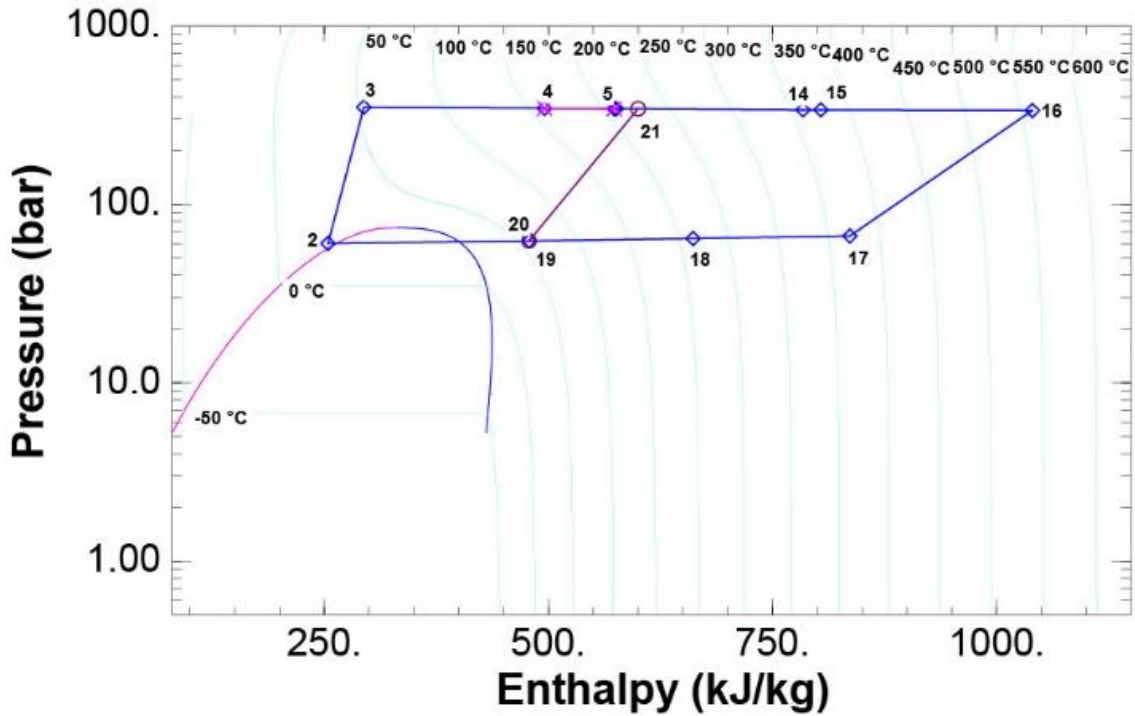

Figure 3 Pressure- Enthalpy diagram of transcritical Recompression CO₂ Cycle, State points correspond to the numbers stated in Figure 2

2.1. Auxiliary Heat Source and Fast Ramping System

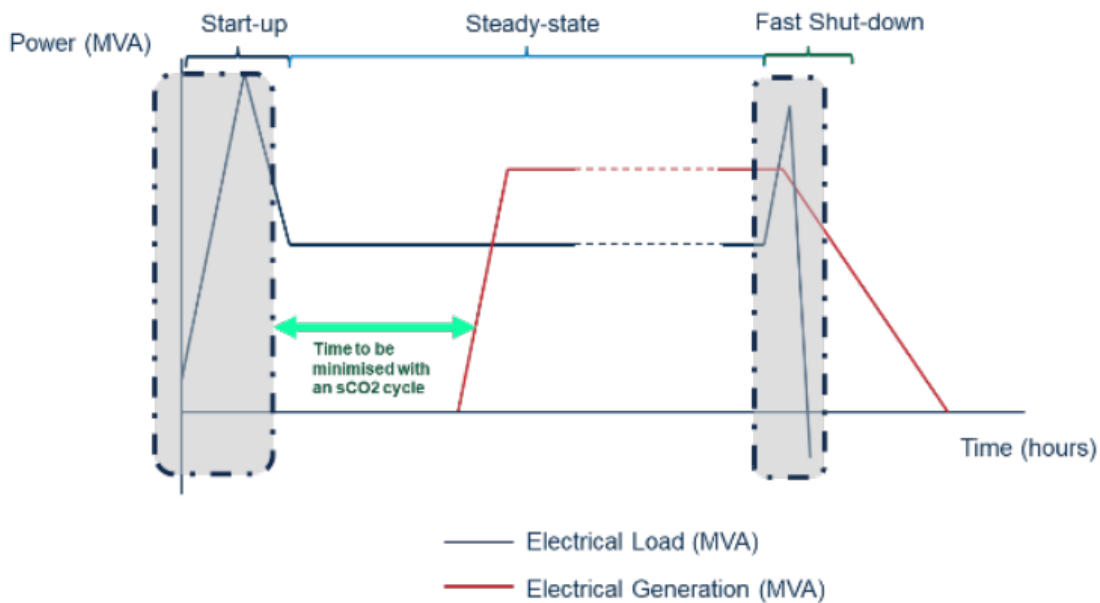

Figure 4 Fusion Power Plant Power Generation and Parasitic Profile

Figure 4 illustrates the representative dynamic electric power generation and parasitic load profile of a fusion power plant during start-up and shutdown. As plasma ignition occurs within a few minutes, it is essential to provide an independent heat source to maintain operation of the power cycle during non-fusion periods. A Fusion Independent Heating System (FIHS) is therefore integrated to supply thermal energy to the cycle when fusion heat is unavailable.

The auxiliary heating system is sized based on the most demanding of the following operating conditions:

- ☒ supporting cold start-up and maintaining the power cycle at its minimum stable load to enable a smooth transition to fusion power,
- ☒ rapid cut-in during cycle shutdowns to sustain minimum load between pulses,
- ☒ facilitating controlled shutdowns when required.

The key functional requirements of the FIHS are as follows:

- Enable independent start-up of the power cycle, including the turbine, without reliance on fusion heat.
- Maintain turbine inlet temperatures close to fusion-mode conditions to minimise thermal stress during plasma heat ramp-up.
- Operate the power cycle at its minimum stable load while synchronised to the grid, ensuring rapid load ramp-up during plasma power increase.
- Sustain low-load operation during dwell or flat-top phases to maintain the system in hot-standby mode, allowing immediate cut-in during fusion reactor shutdowns.

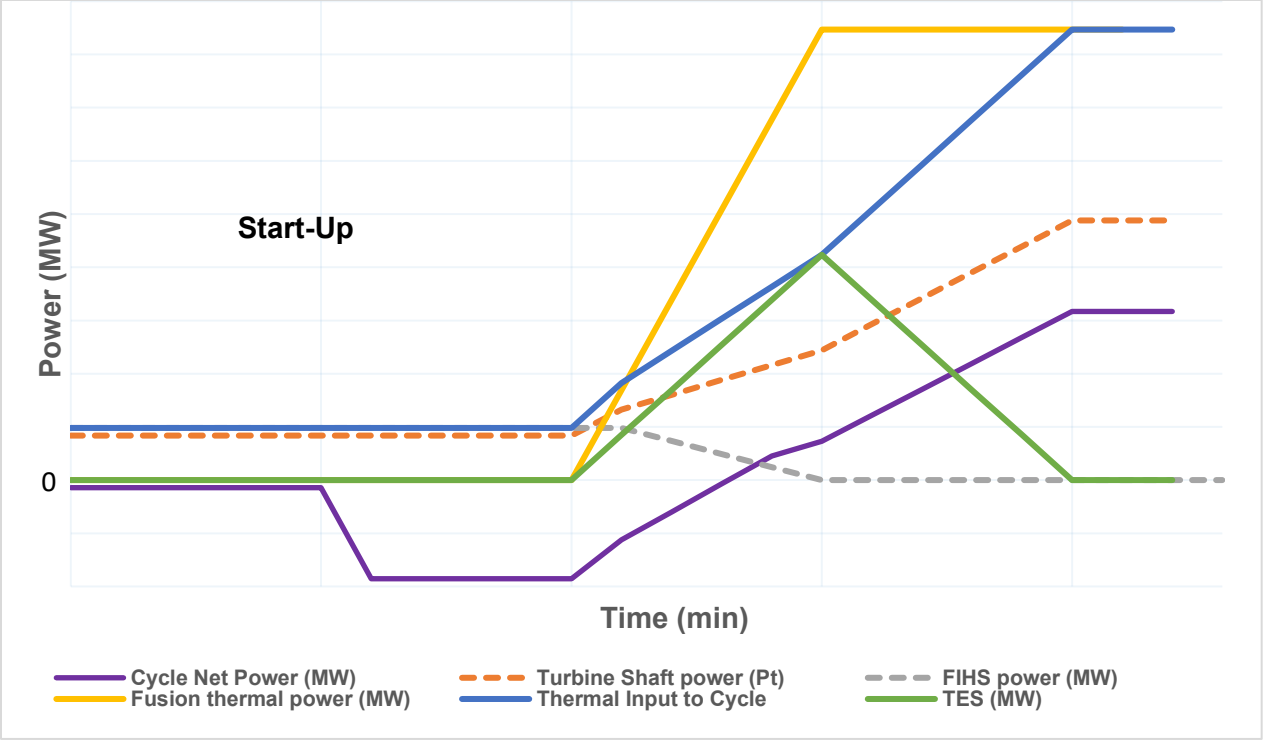

Figure 5 Start-up Process Philosophy

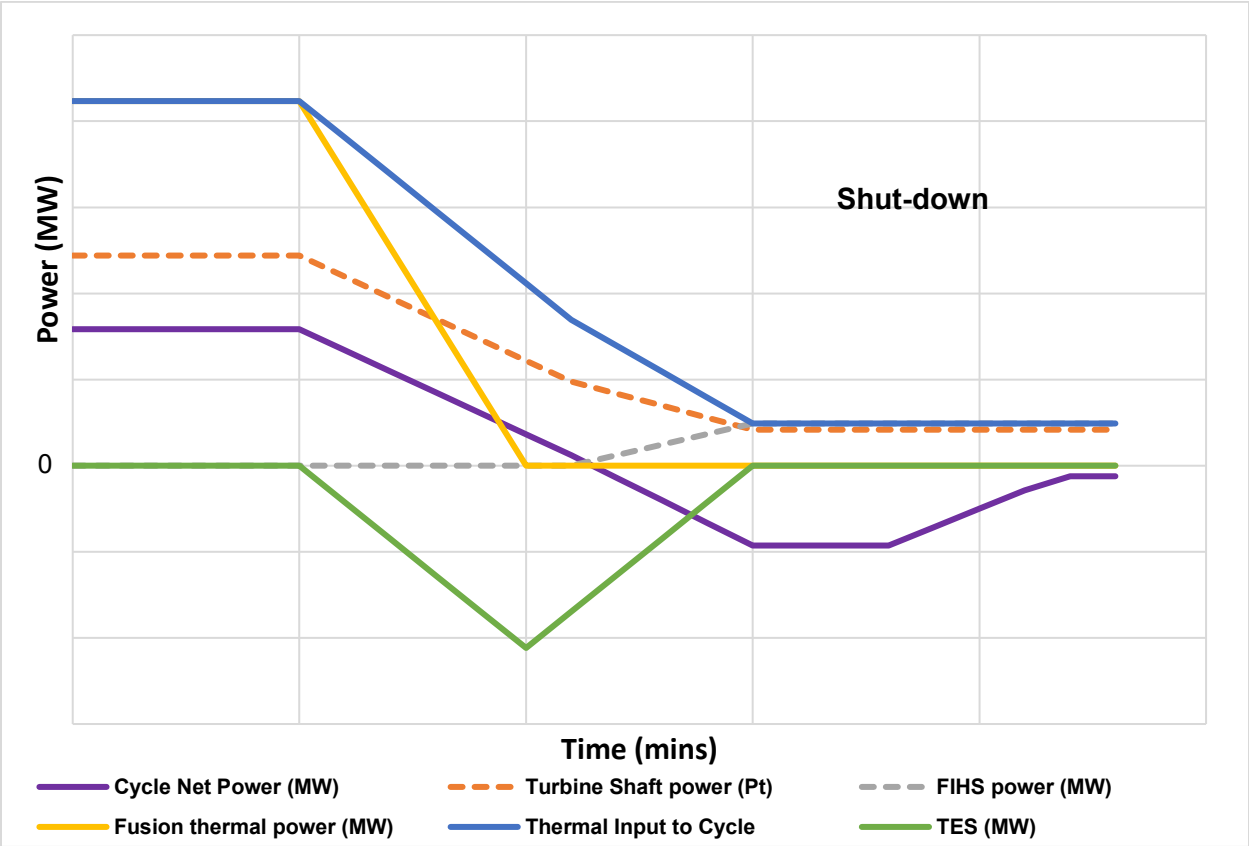

Figure 6 Shut-down Process Philosophy

- Minimise CO₂ emissions, with the goal of achieving near-zero emissions where technology permits.
- Avoid reliance on external infrastructure, such as CO₂ sequestration systems or the electrical grid, where feasible.
- Employ mature, commercially proven technologies to minimise technical risk and system complexity.

A fast-responsive Thermal Energy Storage (TES) system is incorporated as a dedicated thermal buffer to manage the rapid heat-duty variations characteristic of pulsed-operation fusion plants. The TES absorbs high power during start-up and releases heat during shut-down or plasma trips, stabilising the supercritical CO₂ power cycle during abrupt transitions between pulse and dwell, as well as during controlled start-up and shut-down. Its central role is to bridge the mismatch between the fast thermal dynamics of the plasma, where heat can rise or fall within seconds to minutes, and the slower, thermally constrained inertia dominated response of large heat exchangers, pipe(s), and turbomachinery.

During start-up, the power cycle is brought online from cold and held at minimum stable load using the FIHS. As plasma heating begins, the power cycle cannot follow the rapid heat flux rise due to allowable thermal-ramp limits. The molten-salt TES is maintained in hot-standby with a trickle flow through the CO₂-salt heat exchanger to establish the desired temperature profile (e.g., 1% operation [25]). As plasma power increases, primary coolant flow ramps to maintain the tokamak outlet temperature, with only a controlled fraction routed to the power cycle while the remainder is diverted to the TES for charging. Once full plasma power is reached, the TES bypass fraction is progressively reduced to allow the power cycle to ramp to its full load, eventually returning the TES to a trickle-flow condition. This produces the characteristic inverted V-shaped charging trajectory shown in Figure 5.

During shutdown, the sequence reverses. As fusion heat falls, the TES switches to discharge mode (shown as negative in Figure 6), supplying heat to the power cycle at a rate that mirrors the plasma ramp-down. The molten-salt heat exchanger must again ramp from near-zero to maximum duty within the plasma shutdown timeframe, temporarily acting as the dominant thermal source to ensure a smooth decline in cycle heat input. After fusion heat reaches zero, TES discharge tapers down to permit a controlled reduction in power-cycle load.

As TES nears its minimum charge state, the FIHS cuts-in for maintaining the cycle at minimum stable load and its required operating temperature. Continuous minimum-load operation prevents turbomachinery start-stop cycling and ensures rapid readiness for the next pulse. The FIHS also eliminates the need for large energy storage capacity and decouples cycle operability from uncertainties in pulse, dwell, and shutdown durations.

This operating regime places stringent demands on the TES heat exchanger. It must accommodate flow / heat-flux ramps from near-zero to full load at rates far exceeding those encountered in conventional TES deployments. While molten-salt TES systems are commercially deployed at gigawatt-hour thermal scales, the associated molten salt steam generators typically operate in the 50–100 MW_{th} range and are limited to temperature ramp rates of ~10 K/min [25].

Fusion start-up support instead requires high thermal power (500–1000 MW_{th}) but only moderate energy capacity (100–200 MWh_{th}), dictated by the plasma ramp duration. This combination of high instantaneous power, modest stored energy, and rapid thermal response constitutes a unique design challenge from solar-thermal TES applications [25]. It also necessitates tightly coordinated control of TES charge–discharge behaviour and integrated validation with the supercritical CO₂ cycle and FIHS to demonstrate overall plant feasibility.

3. Proof of Concept (PoC) Rig

The aim of the PoC rig is to validate the steady-state and dynamic performance, as well as the operational flexibility, and control strategies of the integrated power cycle with FIHS and TES, while providing operating experience and confirming its suitability for the STEP prototypic fusion plant.

Figure 7 shows the schematic diagram of PoC test rig illustrating the integrated CO₂ power cycle with the FIHS and TES. The rig replicates the thermal architecture of the STEP power conversion system at reduced scale of circa 200 kWe, incorporating turbomachinery, recuperators, and a heat-rejection loop. Fusion heat is emulated using electric heaters representing multi-grade heat inputs. The FIHS and TES are connected in parallel with the high-temperature heater, enabling controlled heat supply and rejection during simulated “pulse” and “dwell” conditions. This configuration allows validation of dynamic response, mode switching, and operational control strategies of the integrated cycle under fusion-relevant thermal transient, including start-up, shut-down, trip scenarios. The test programme aims to evaluate different down selected candidate FIHS and TES technologies to support finalising an integrated solution that best satisfies SPP functional and operational requirements.

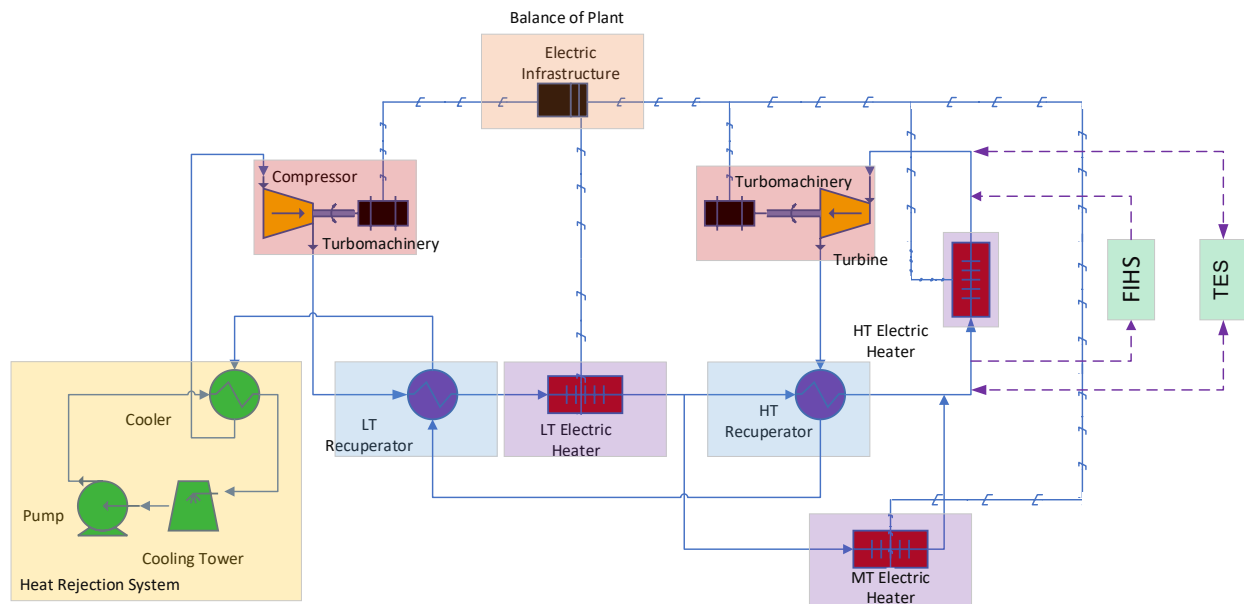

Figure 7 PoC Rig Simplified Diagram (CO₂ cycle based)

The programme focuses on demonstrating stable and autonomous operation under fusion-relevant steady-state and transient conditions, while providing critical data for component model validation, control development, and scale-up to the STEP prototypic powerplant. The key objectives are as follows:

- Verify integrated operation of the complete power cycle, including start-up, shut-down, and emergency procedures under autonomous control.
- Demonstrate steady-state operation in both fusion-heat and auxiliary-heat modes, and validate smooth, controlled transitions between modes.
- Evaluate the responsiveness and stability of the candidate FIHS during low-load operation, rapid ramping, and transient events.
- Assess the thermal response and control performance of the TES, verifying compliance with component limits during fast transients.
- Validate steady-state, off-design, and transient performance of key components, including TES, FIHS, heat exchangers, and turbomachinery, as well as the resulting system-level interactions, against design predictions.
- Acquire operational experience with a closed-loop CO₂ power cycle under representative fusion-relevant conditions to support SPP integration.

The test rig is configured to replicate the representative heat split of the SPP, as summarised in Table 1. While operating at a lower overall pressure ratio than the full-scale SPP, the rig achieves equivalent maximum cycle temperatures to reproduce the thermal and material challenges relevant to the FIHS and TES subsystems. The recompressor is omitted from the current configuration to minimise system complexity and cost, as its control behaviour in closed-loop CO₂ cycles is already being investigated within the sCO₂ research community at this scale. Owing to its relatively small contribution to STEP fusion power cycle, the recompressor functions primarily as an efficiency enhancement component and can be brought online in a controlled manner once the transition from FIHS to fusion heat is complete. Although this approach results in a temporary reduction in efficiency, the penalty is confined to the start-up phase and is therefore considered acceptable. Consequently, its exclusion is not expected to influence the mode transition dynamics or the primary objectives of the test programme. Detailed design and integration aspects of the FIHS are retained for forthcoming publications as part of ongoing development activities, and proprietary reasons.

It should be noted that the dynamic response, characteristic time constants, and thermal inertia observed in the small-scale test rig will not fully replicate those of the SPP, owing to inherent scaling effects and significantly reduced component mass and inventory. Nevertheless, the experimental platform provides a critical opportunity to validate underlying dynamic models, control strategies, and subsystem interactions under representative thermodynamic conditions. Once validated, these models can be digitally scaled to plant-relevant scale, enabling prediction of large-scale systems. The insights gained will support the future development of a scale-up test facility of size 2–10 MW, where scaled turbomachinery, heat exchangers, and auxiliary heat source can be tested under more realistic dynamic loading conditions. This staged approach allows systematic evaluation of component performance, operational limits, and integration challenges before deployment in the full SPP architecture. A detailed overview of the roadmap,

is provided in a companion paper presented at this conference, titled “Developing a Technology Roadmap for STEP’s sCO₂ Cycle: SHOCC.”

4. Conclusions

This study outlines the development of a proof-of-concept (PoC) experimental facility designed to demonstrate, for the first time, the integration of a closed-loop CO₂ power cycle with a Fusion-Independent Heating System (FIHS) and fast-response Thermal Energy Storage (TES) for fusion-relevant operation. The primary novelty of this work lies in its focus on enabling continuous power-cycle operation through both flat-top and dwell periods, thereby addressing one of the most critical challenges for intermittent operation fusion powerplants: avoiding repeated start–stop cycling and the associated thermal fatigue of turbomachinery and heat-exchange components. By replicating the representative thermodynamic states of the Spherical Tokamak for Energy Production (STEP) power cycle at a ~200 kWe scale, the PoC facility provides a controlled and representative platform for evaluating subsystem performance, controllability, and system-level interactions under dynamic, fusion-like boundary conditions.

The experimental campaign will generate to validate steady-state, off-design, and transient behaviour; assess the effectiveness of FIHS–TES coupling during rapid mode transitions; and refine control strategies essential for maintaining turbine operation in the absence of fusion heat input. These results will be directly applied to reduce uncertainties in scaling and inform the future scale-up rig. The dynamic characteristics achieved at the PoC scale will complement the subsequent scale-up programme, which is intended to replicate representative full-scale system dynamics and verify the performance of scaled turbomachinery, heat exchangers, and associated closed-loop system-level interactions. Therefore, a successful demonstration of the integrated cycle at the PoC scale will provide critical evidence of the technical feasibility of the STEP power-conversion concept, reinforcing confidence in the development of reliable, flexible, and resilient power systems for next-generation fusion powerplants.

REFERENCES

- [1] Methven, P., 2024, “STEP-Organizing a Major Project to Tackle Significant Uncertainty,” *Philosophical Transactions of the Royal Society A: Mathematical, Physical and Engineering Sciences*, **382**(2280). <https://doi.org/10.1098/rsta.2023.0402>.
- [2] Acres, J., Antoniou, I., Christie, F., Blackburn, D., and Knight, S., 2024, “Staying Positive: Producing Net Power,” *Philosophical Transactions of the Royal Society A: Mathematical, Physical and Engineering Sciences*, **382**(2280). <https://doi.org/10.1098/rsta.2023.0404>.
- [3] Cane, J., Barth, A., Farrington, J., Flynn, E., Kirk, S., Lilburne, J., and Vizvary, Z., 2024, “Managing the Heat: In-Vessel Components,” *Philosophical Transactions of the Royal Society A: Mathematical, Physical and Engineering Sciences*, **382**(2280). <https://doi.org/10.1098/rsta.2023.0408>.
- [4] Barucca, L., Hering, W., Perez Martin, S., Bubelis, E., Del Nevo, A., Di Prinzio, M., Caramello, M., D’Alessandro, A., Tarallo, A., Vallone, E., Moscato, I., Quartararo, A., D’amico, S., Giannetti, F., Lorusso, P., Narcisi, V., Ciurluini, C., Montes Pita, M. J., Sánchez, C., Rovira, A., Santana, D., Gonzales, P., Barbero, R., Zaupa, M., Szogradi, M., Normann, S., Vaananen, M., Ylatalo, J., Lewandowska, M., Malinowski, L., Martelli, E., Froio, A., Arena, P., and Tincani, A., 2022, “Maturation of Critical Technologies for the DEMO Balance of Plant Systems,” *Fusion Engineering and Design*, **179**. <https://doi.org/10.1016/j.fusengdes.2022.113096>.
- [5] Wang, S., Hernández, F. A., Bubelis, E., and Chen, H., 2019, “Comparative Analysis of the

- Efficiency of a CO₂-Cooled and a He-Cooled Pebble Bed Breeding Blanket for the EU DEMO Fusion Reactor,” *Fusion Engineering and Design*, **138**, pp. 32–40. <https://doi.org/10.1016/j.fusengdes.2018.10.026>.
- [6] International Renewable Energy Agency, I., 2019, *Flexibility in Conventional Power Plants: Innovation Landscape Brief*. [Online]. Available: www.irena.org.
- [7] 2018, *ITER Research Plan within the Staged Approach (Level III-Provisional Version)*. [Online]. Available: https://www.iter.org/sites/default/files/ITER-Research-Plan_final_ITR_FINAL-Cover_High-Res.pdf. [Accessed: 03-Mar-2025].
- [8] Moscato, I., Barucca, L., Bubelis, E., Caruso, G., Ciattaglia, S., Ciurluini, C., Del Nevo, A., Di Maio, P. A., Giannetti, F., Hering, W., Lorusso, P., Martelli, E., Narcisi, V., Norrman, S., Pinna, T., Perez-Martin, S., Quartararo, A., Szogradi, M., Tarallo, A., and Vallone, E., 2022, “Tokamak Cooling Systems and Power Conversion System Options,” *Fusion Engineering and Design*, **178**. <https://doi.org/10.1016/j.fusengdes.2022.113093>.
- [9] Acres, J., and Clements, C., 2024, “Fusion Energy and Future Fusion Power Plants,” *Volume 5: Cycle Innovations*, American Society of Mechanical Engineers. <https://doi.org/10.1115/GT2024-126730>.
- [10] Barucca, L., Bubelis, E., Ciattaglia, S., D’Alessandro, A., Del Nevo, A., Giannetti, F., Hering, W., Lorusso, P., Martelli, E., Moscato, I., Quartararo, A., Tarallo, A., and Vallone, E., 2021, “Pre-Conceptual Design of EU DEMO Balance of Plant Systems: Objectives and Challenges,” *Fusion Engineering and Design*, **169**. <https://doi.org/10.1016/j.fusengdes.2021.112504>.
- [11] Thanganadar, D., and Acres, J., 2024, “Thermodynamic Design and Analysis Of Steam Rankine Cycle For Nuclear Fusion Application,” *Volume 5: Cycle Innovations*, American Society of Mechanical Engineers. <https://doi.org/10.1115/GT2024-129397>.
- [12] Dostal, V., Driscoll, M. J., and Hejzlar, P., 2004, “A Supercritical Carbon Dioxide Cycle for Next Generation Nuclear Reactors.”
- [13] Follett, W. W., Moore, I. J., Sylvain, J. W., and Manager, P., *The 8th International Supercritical CO₂ Power Cycles Symposium The STEP 10 MWe SCO₂ Pilot Installation and Commissioning Status Update*.
- [14] Jiang, Y., Liese, E., Zitney, S. E., and Bhattacharyya, D., 2018, “Design and Dynamic Modeling of Printed Circuit Heat Exchangers for Supercritical Carbon Dioxide Brayton Power Cycles,” *Appl Energy*, **231**(March), pp. 1019–1032. <https://doi.org/10.1016/j.apenergy.2018.09.193>.
- [15] Alfani, D., Astolfi, M., Binotti, M., Campanari, S., Casella, F., and Silva, P., 2019, “Multi Objective Optimization of Flexible Supercritical CO₂ Coal-Fired Power Plants,” *Proceedings of the ASME Turbo Expo*, American Society of Mechanical Engineers (ASME). <https://doi.org/10.1115/GT2019-91789>.
- [16] 2018, *10 MWe Supercritical Carbon Dioxide (SCO₂) Pilot Power Plant*. [Online]. Available: <https://www.gti.energy/wp-content/uploads/2019/01/STEP-Project-Detailed-Description-Dec2018.pdf>. [Accessed: 09-Apr-2025].
- [17] Hacks, A. J., El Hussein, I. A., Ren, H., Schuster, S., and Brillert, D., 2022, “Experimental Data of Supercritical Carbon Dioxide (SCO₂) Compressor at Various Fluid States,” *J Eng Gas Turbine Power*, **144**(4). <https://doi.org/10.1115/1.4052954>.
- [18] Antonio, S., Dawson, L., and Carlson, M., 2016, *Demonstration Testing and Facility Requirements for SCO₂ Brayton Commercialization*.
- [19] Linares, J. I., Cantizano, A., Moratilla, B. Y., Martín, V., and Batet, L., 2016, *Supercritical CO₂ Brayton Power Cycles for DEMO Fusion Reactor Based on Dual Coolant Lithium Lead Blanket*. <https://doi.org/10.1016/j.energy.2016.01.020>.
- [20] Syblik, J., Entler, S., Veselý, L., Štěpánek, J., and Dostál, V., 2022, “Fusion DEMO SCO₂ Layout Design with Battery Farm,” *Energy*, **249**. <https://doi.org/10.1016/j.energy.2022.123730>.
- [21] Vesely, L., Syblik, J., Entler, S., Stepanek, J., Zacha, P., and Dostal, V., 2020, “Optimization of Supercritical CO₂ Power Conversion System with an Integrated Energy Storage for the Pulsed DEMO,” *IEEE Transactions on Plasma Science*, **48**(6), pp. 1715–1720. <https://doi.org/10.1109/TPS.2020.2971718>.
- [22] Waldon, C., Muldrew, S. I., Keep, J., Verhoeven, R., Thompson, T., and Kisbey-Ascott, M.,

- 2024, "Concept Design Overview: A Question of Choices and Compromise," *Philosophical Transactions of the Royal Society A: Mathematical, Physical and Engineering Sciences*, **382**(2280). <https://doi.org/10.1098/rsta.2023.0414>.
- [23] Thanganadar, D., and Acres, J., 2026, "Thermodynamic Performance Evaluation of Power Cycle Technologies for Spherical Tokamak Energy Production," *Fusion Engineering and Design*, **222**. <https://doi.org/10.1016/j.fusengdes.2025.115451>.
- [24] Thanganadar, D., Asfand, F., and Patchigolla, K., 2019, "Thermal Performance and Economic Analysis of Supercritical Carbon Dioxide Cycles in Combined Cycle Power Plant," *Appl Energy*, **255**(September), p. 113836. <https://doi.org/10.1016/j.apenergy.2019.113836>.
- [25] Mehos, M., Price, H., Cable, R., Kearney, D., Kelly, B., Kolb, G., and Morse, F., 2020, *Concentrating Solar Power Best Practices Study*. [Online]. Available: <https://docs.nrel.gov/docs/fy20osti/75763.pdf>. [Accessed: 19-Nov-2025].

ACKNOWLEDGEMENTS

This work has been funded by STEP, a major technology and infrastructure programme led by UK Industrial Fusion Solutions Ltd (UKIFS), which aims to deliver the UK's prototype fusion powerplant and a path to the commercial viability of fusion. To obtain further information on the data and models underlying this paper please contact PublicationsManager@ukaea.uk.