

The 5th International Supercritical CO₂ Power Cycles Symposium
March 29 - 31, 2016, San Antonio, Texas

Optimization of S-Shaped Fin Channels in a Printed Circuit Heat Exchanger for Supercritical CO₂ Test Loop

Xiaoqin Zhang, Xiaodong Sun, Richard Christensen

Nuclear Engineering Program, The Ohio State University

Mark Anderson

Department of Engineering Physics, University of Wisconsin, Madison

Matthew Carlson

Sandia National Laboratories

Work Supported by DOE Nuclear Energy University Programs

3/31/2016



THE OHIO STATE UNIVERSITY



WISCONSIN
UNIVERSITY OF WISCONSIN-MADISON

Overview

- **Introduction**
 - Background
 - Project activity
- **Surface geometry of S-shaped fin channels**
- **Numerical studies**
 - Computational domain and numerical simulation setup
 - Selection of simulation cases
- **Shape Optimization**
 - Surrogate modeling
 - Optimization algorithms
 - Discussion of results
- **Conclusion**



Background

- Advanced nuclear reactor concepts, supercritical CO₂ Brayton cycle & intermediate heat exchangers (IHX)
 - Working fluids at the primary loop include helium, liquid metal and molten salt, etc.
 - Supercritical CO₂ (s-CO₂) Brayton cycle used as power conversion units are thermally-efficient and compact
 - Intermediate heat exchangers couple the primary and secondary systems (a helium-Gas-cooled Fast Reactor (GFR) is coupled with s-CO₂ Brayton cycle)
 - One of promising IHX candidates is Printed Circuit Heat Exchangers (PCHEs)
 - High Compactness
 - Desired thermal performances
 - Cost reduction
 -



Background

- Printed circuit heat exchangers
 - Photo-chemical etched plates stacked up to be diffusion-bonded

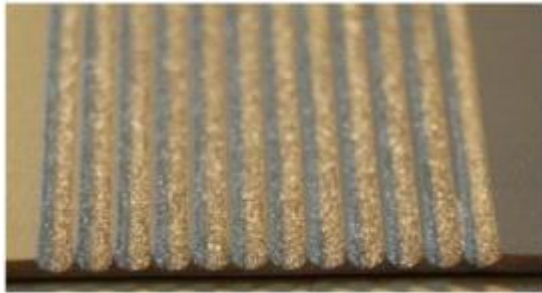

Etched metal plate¹

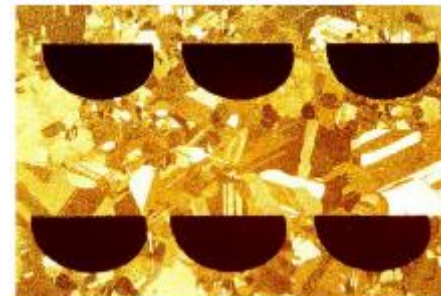

Diffusion-bonded plates¹



Commercial small-scale PCHE³

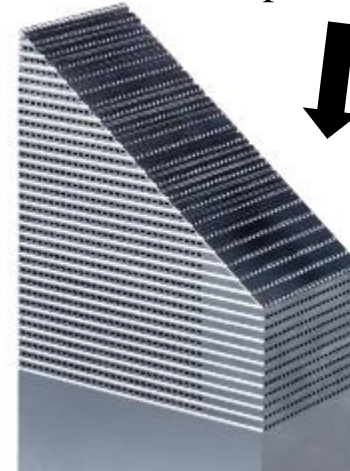

Heat exchanger core²

- [1] S.K. MYLAVARAPU, “Design, Fabrication, Performance Testing, and Modeling of Diffusion Bonded Compact Heat Exchangers in a High-Temperature Helium Test Facility,” Ph.D. dissertation, The Ohio State University (2011).
- [2] Vacuum Processing Engineering Homepage, <http://www.vpei.com/>, (2015)
- [3] Heatric Homepage, <http://www.heatric.com/>, (2015)



Introduction of zigzag and S-shaped fin channels

- Surface geometries of PCHEs
 - Straight channels and zigzag channels (Heatric Company)
 - S-shaped fin channels, first investigated by Tokyo Institute of Technology (TIT) in 2007
 - Airfoil fin channels, first investigated by POSTECH in 2008



- Development of S-shaped fin channels
 - Wavy channels cut at the bend corner and down-stream fins shifted to form offset configurations
 - Tips of fins are elongated

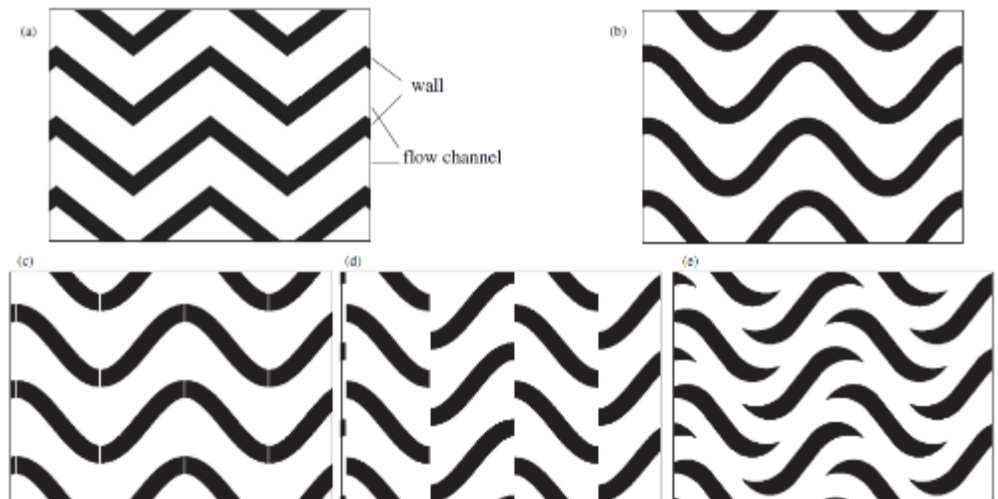

Project Activity

- Objective and technical approach
 - To optimize design of PCHEs (printed circuit heat exchangers) as IHXs (intermediate heat exchangers) using numerical analysis and multi-objective evolutionary algorithms
 - Parametric studies of PCHEs with various kinds of surface geometries
 - Numerical studies on thermal performances of proposed PCHE designs
 - Thermal-economic multi-objective optimization to PCHE designs
 - Evaluation of the structural integrity of proposed the PCHE design using the numerical simulation
 - To fabricate and test scaled-down prototypic PCHEs
 - Design and **construction of s-CO₂ test loop (STL) facility**
 - Design and **fabrication of scaled-down prototypic PCHEs** with different working fluids
 - Experimental tests for steady-state and transient conditions
 - To study the diffusion bonding techniques
 - Post testing from the tested PCHE



Design of s-CO₂ Test Loop (STL) Facility

- An s-CO₂ Test Loop (STL) is designed to couple with existing high-temperature helium test facility (HTHF) for testing of the IHX Test PCHE
 - The existing HTHF at OSU provides up to 2 MPa and 750 °C
 - The s-CO₂ test loop (STL) is capable of running experiments at 15 MPa and 650 °C

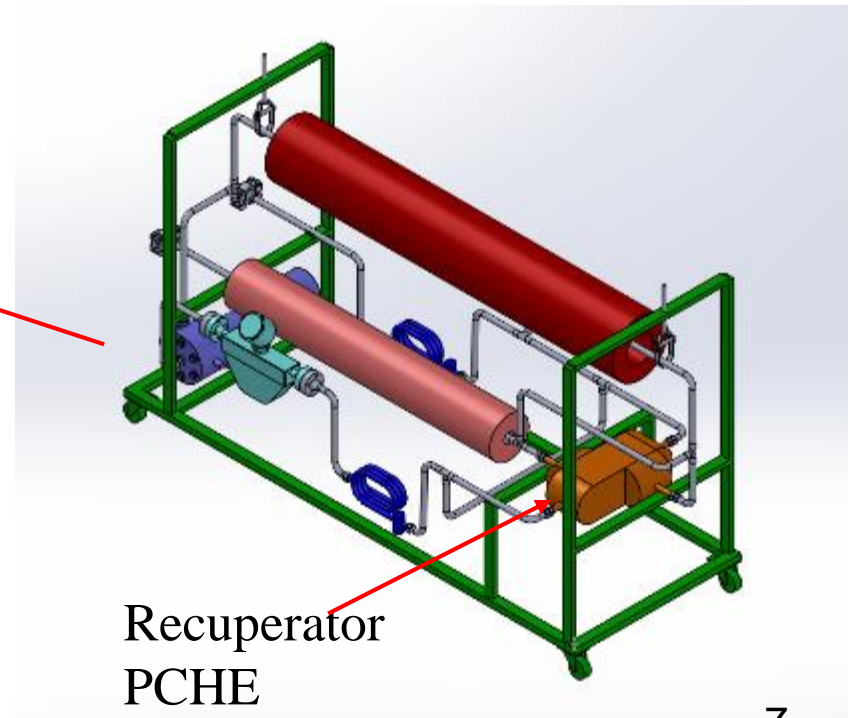
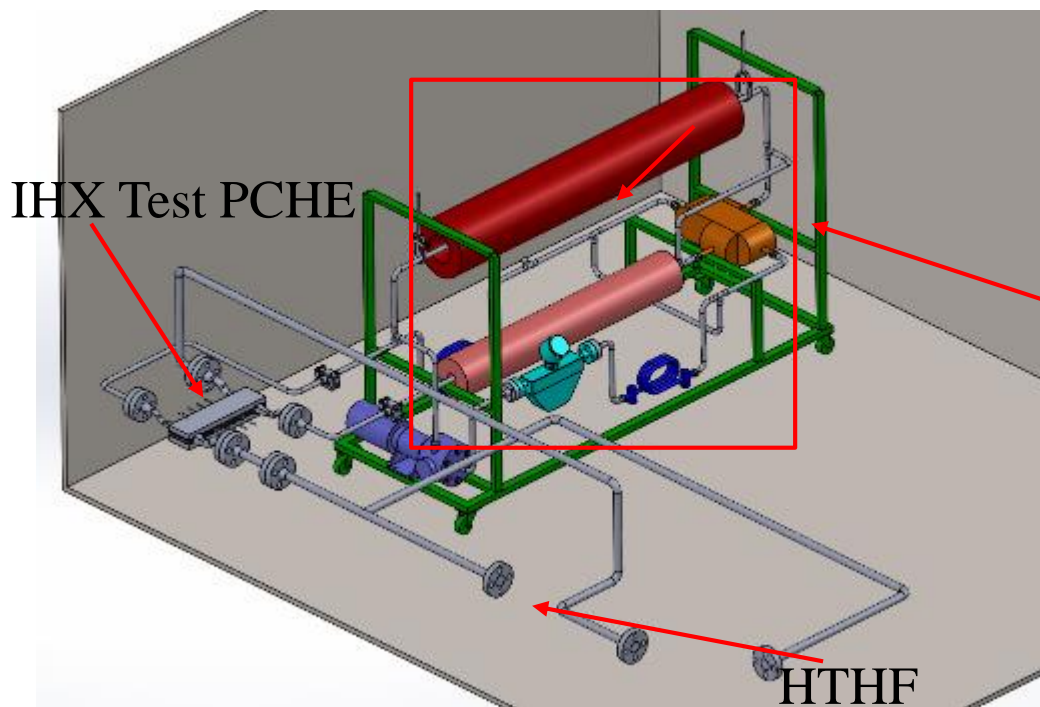

HX Core to Assembly

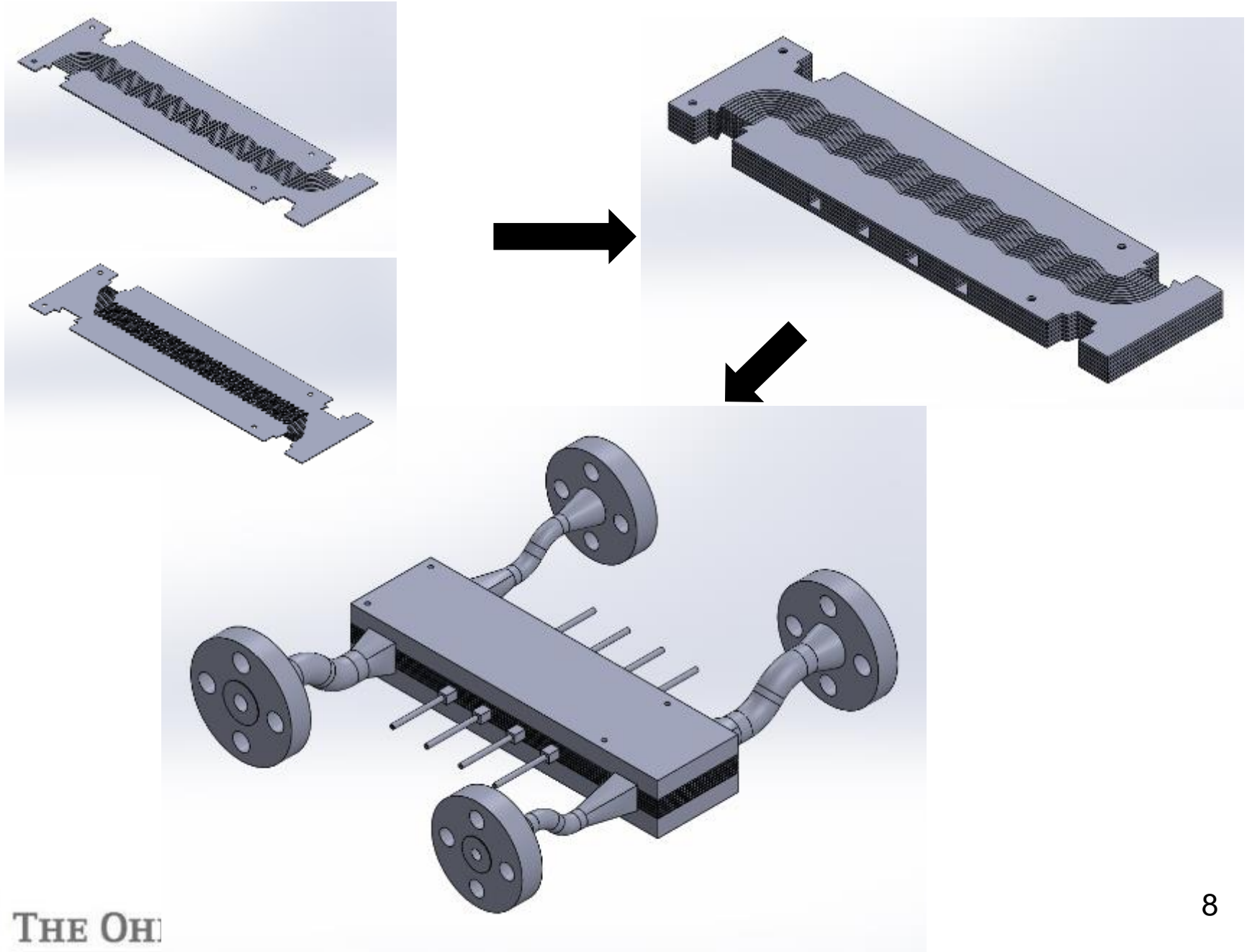

Surface Geometry of S-shaped Fin Channels

- S-shaped fin model is based on the experimentally tested S-shaped fin PCHE surface geometry by TIT (2007)
 - In the model the S-shape is formed by sinusoidal functions defined by the fin length l_f , fin width d_f and fin angle ϕ ; the configuration of fins can be represented by longitudinal and lateral pitch p_y, p_x

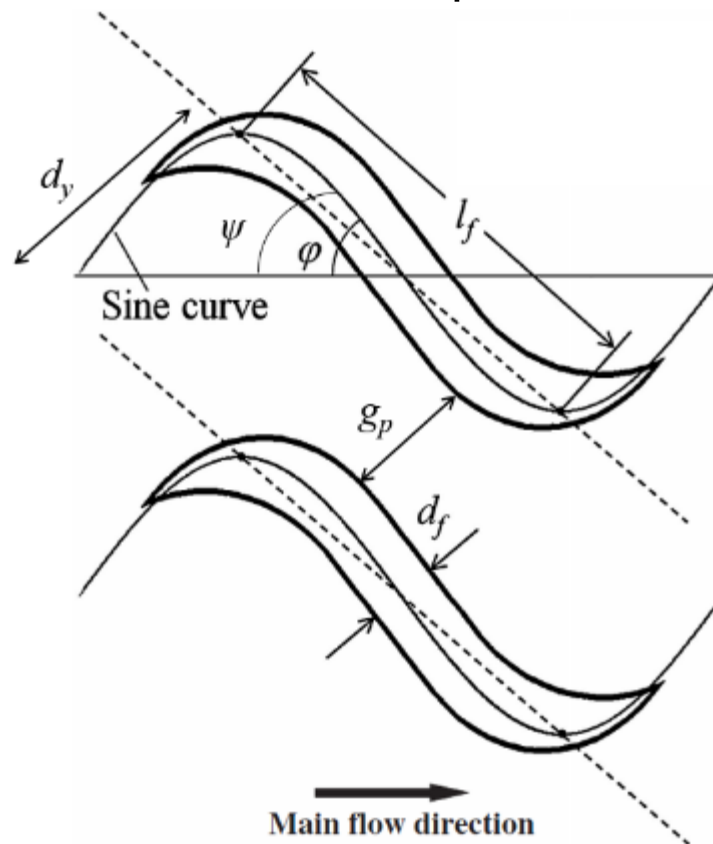

Items	TIT experimental model
Plate thickness, t_p , mm	1.5
Longitudinal pitch, p_y , mm	7.565
Lateral pitch, p_x , mm	3.426
Fin angle, ϕ , °	52
Fin width, d_f , mm	0.8
Fin length, l_f , mm	4.8
Fin height, H , mm	0.94
Hydraulic diameter, D_h , mm	1.09

$$y = \xi \sin(\omega(x - a)) + b.$$



Surface Geometry of S-shaped Fin Channels

- Stress analysis

- A simplified stress analysis for zigzag channels is adopted for determining the neighboring fin distance d_y the longitudinal and lateral pitch p_y, p_x

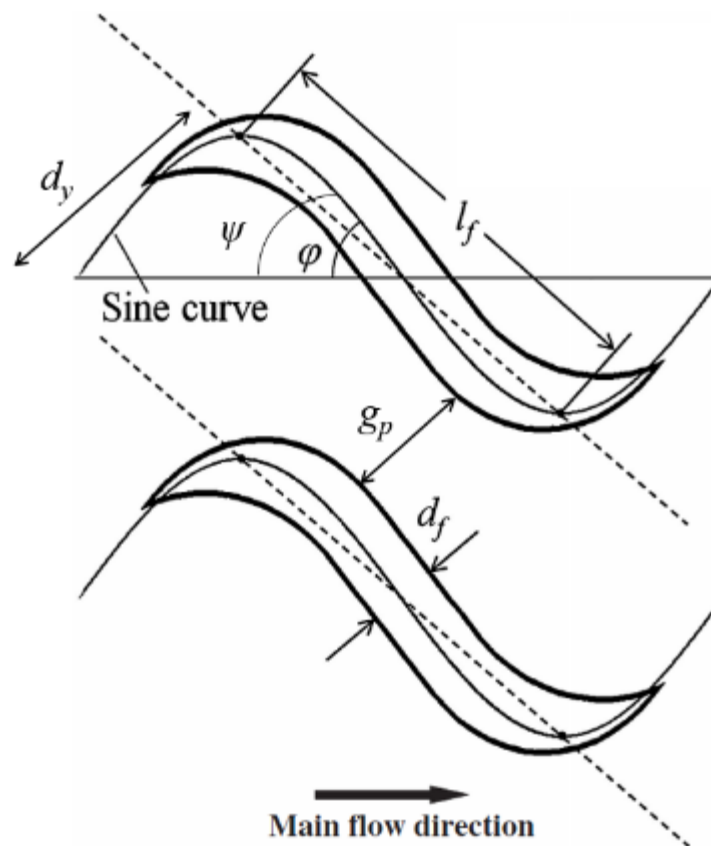

$$d_{f,zz} = \left(\frac{\Delta p}{\sigma_D} \right) g_p,$$

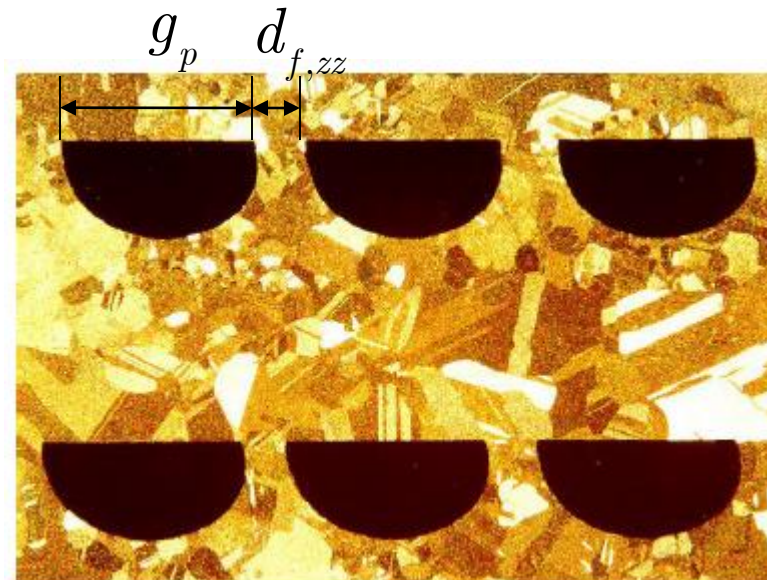

Numerical Studies—Computational Domain

- Computational domain
 - The selected computational domain is periodic in both x- and y-direction. The periodicity can reduce the computational time.
 - The fluid flowing zones are sandwiched by solid plates. S-Shaped discontinuous fins are located in the fluid zones

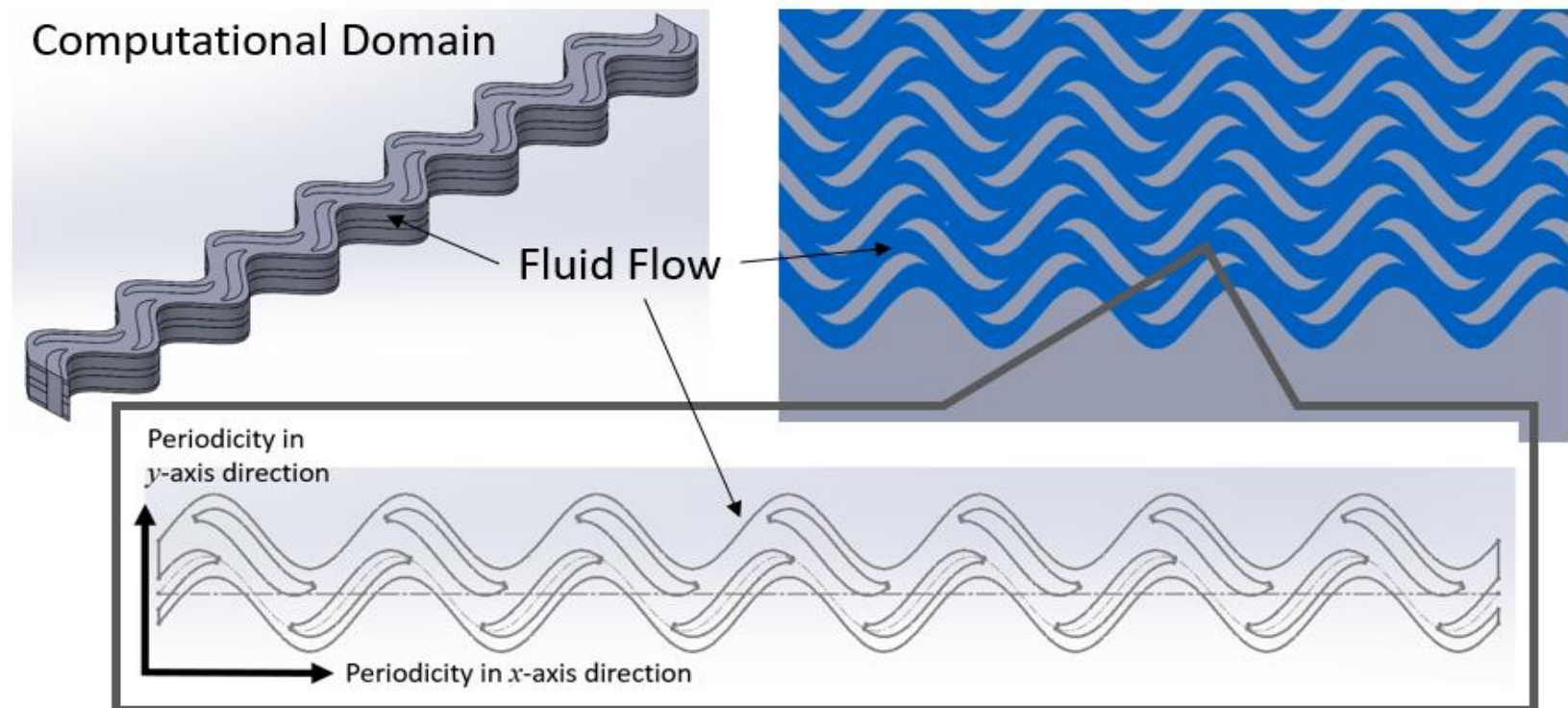

Numerical Simulation Setup

- Numerical simulation setup
 - Inflation layers are required at the vicinity of S-shaped fin walls as well as the upper and lower plate due to the turbulent flow regime
 - The sweeping method is used in the meshing to further reduce the computational cost
 - The k- ϵ Realizable turbulent model is adopted for stable convergence.

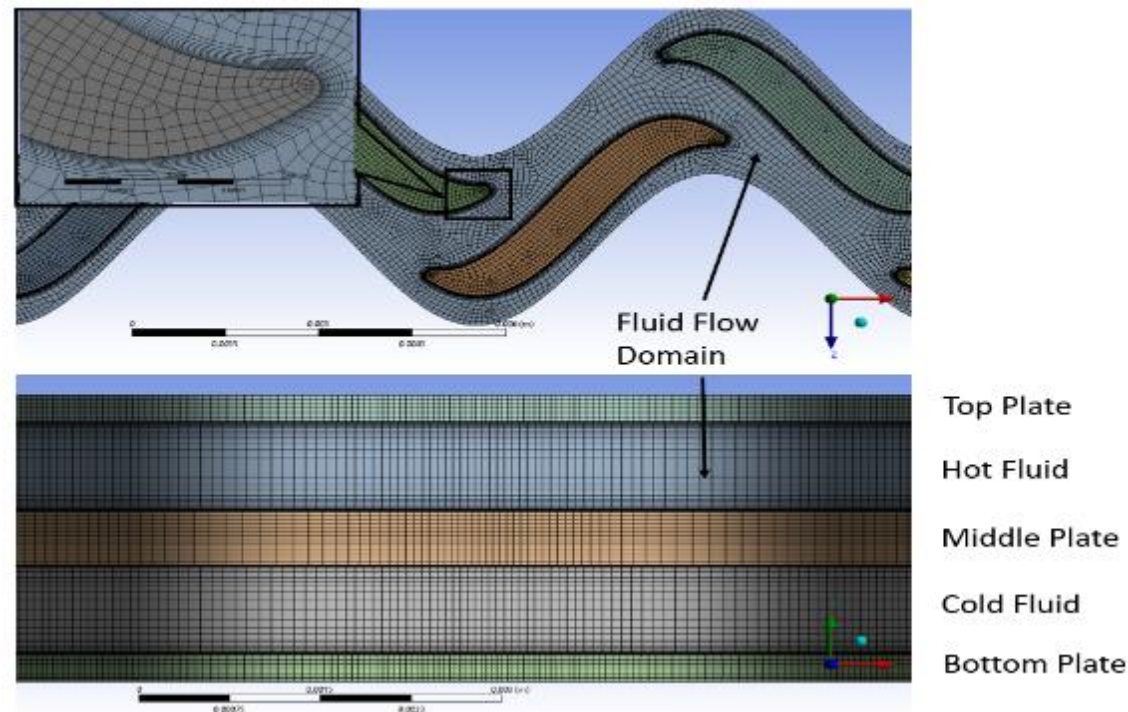

Selection of CFD Simulation Cases

- Design cases selection
 - Besides the CFD simulation for the reference design, it is necessary to perform CFD simulations for various S-shaped fin channel designs for the shape optimization
 - In the design space of the fin angle $10 - 60^\circ$ and the fin length $4 - 16$ mm, 9 cases are selected using Latin Hypercube Sampling (LHS)

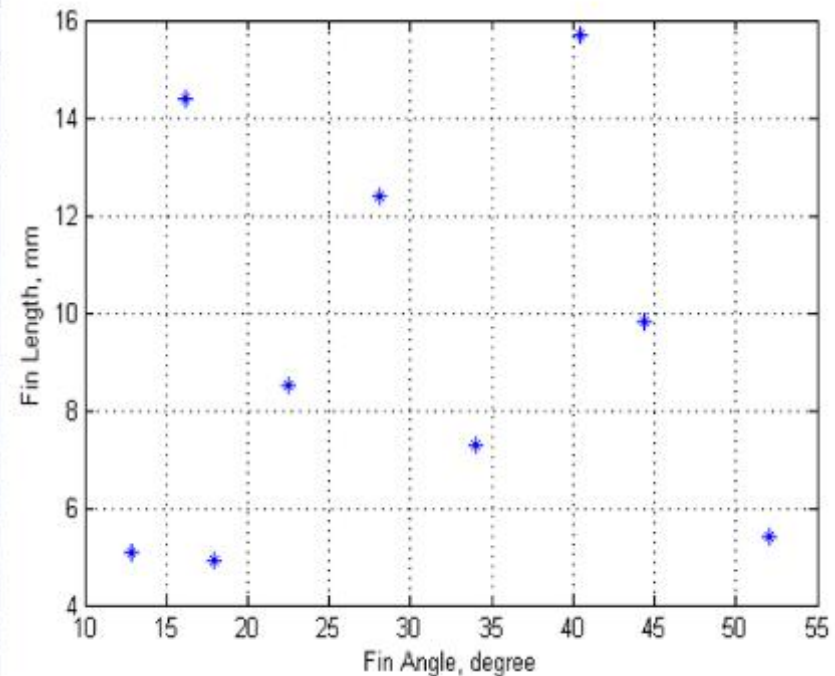
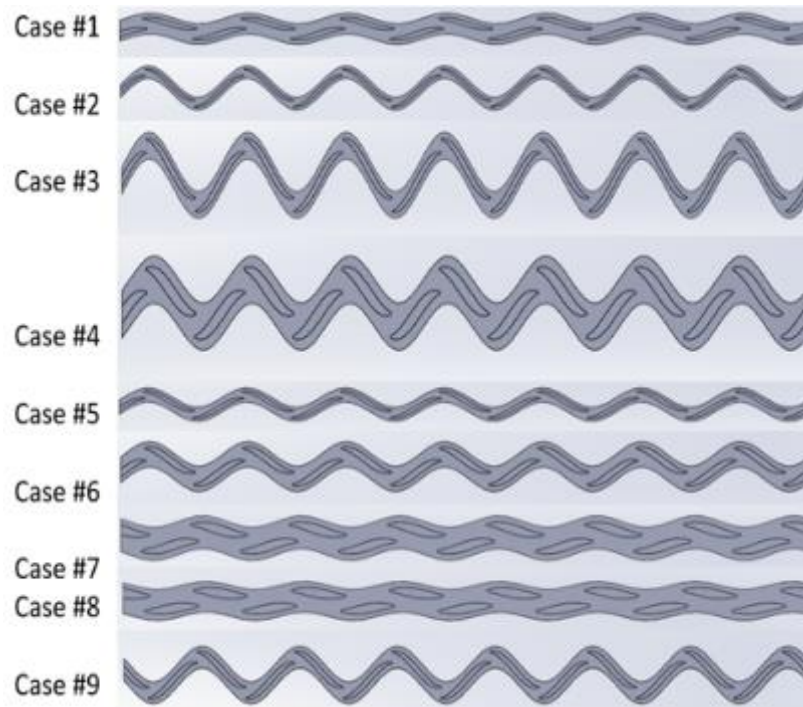

Shape Optimization-- Surrogate Modeling

- Surrogate modeling

- To develop the dependence of the pressure drop and the heat transfer on the fin angle and fin length, the second-order Response Surface Method (RSM) is adopted to develop a surrogate model using the simulation results of 9 cases

$$y = \beta_0 + \sum_{j=1}^k \beta_j x_j + \sum_{j=1}^k \beta_{jj} x_j^2 + \sum_{i < j=2}^k \sum_{i=2}^k \beta_{ij} x_i x_j$$

$$\delta P = \frac{P_1 - P_2}{L_{12}}$$

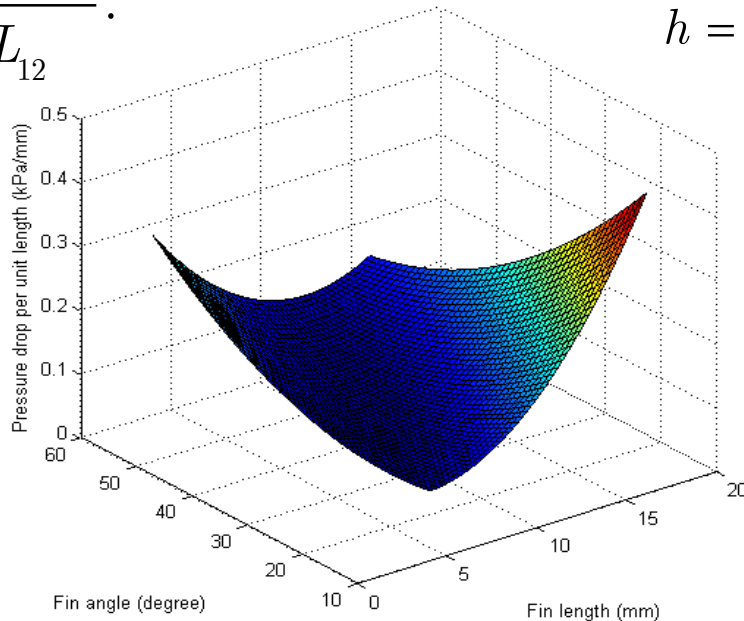

$$h = \left| \frac{Q}{A_s (T_w - T_b)} \right|$$

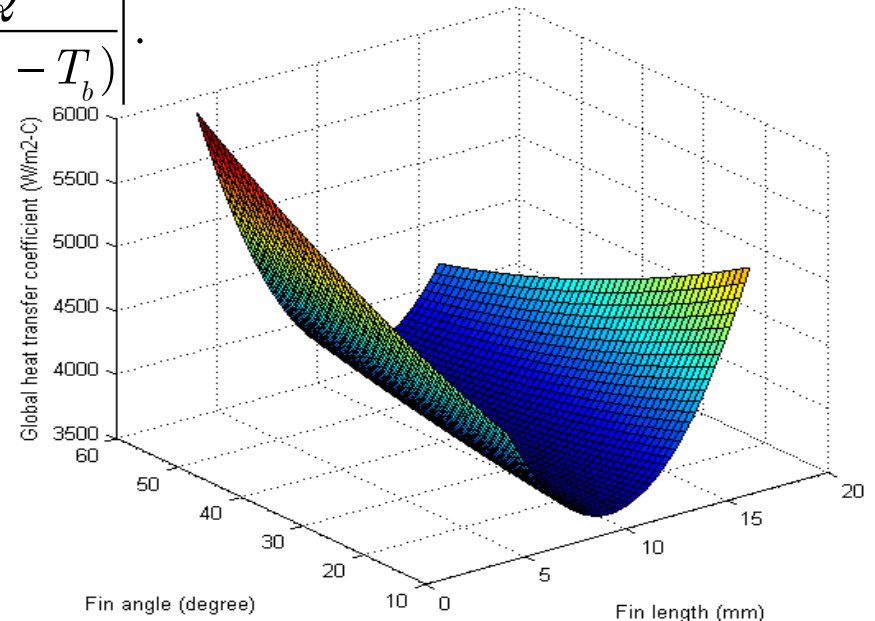

Shape Optimization--Algorithms

- One of the Multi-objective Evolutionary Algorithms (MOEAs) NSGA-II is used to optimize the shape of S-shaped fins
 - The objective functions are the heat exchanger thermal effectiveness and the core pressure drop
 - The selected objective functions are usually conflicting with each other
 - The purpose is to seek a set of non-dominated solutions called Pareto-optimal solutions

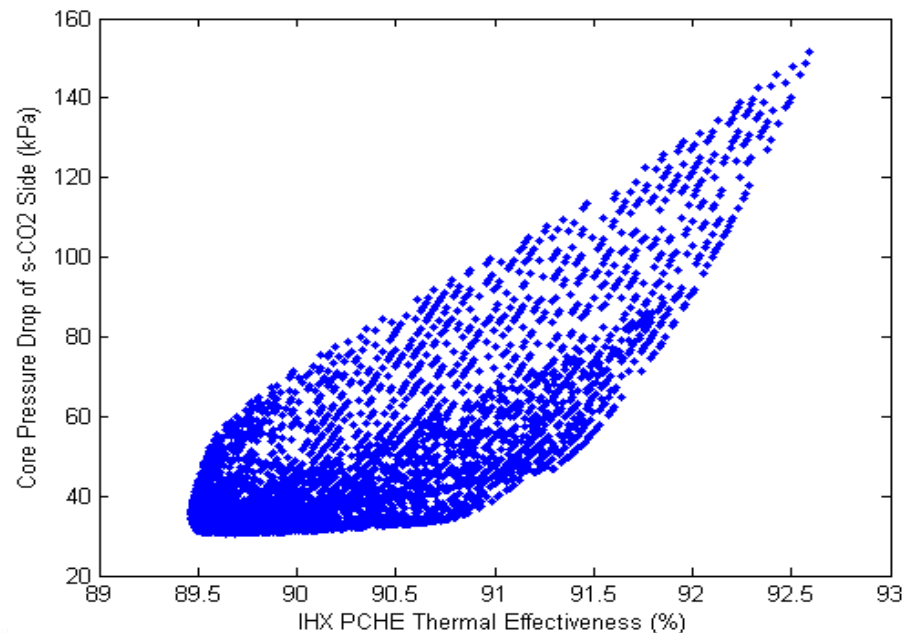

Shape Optimization--Algorithms

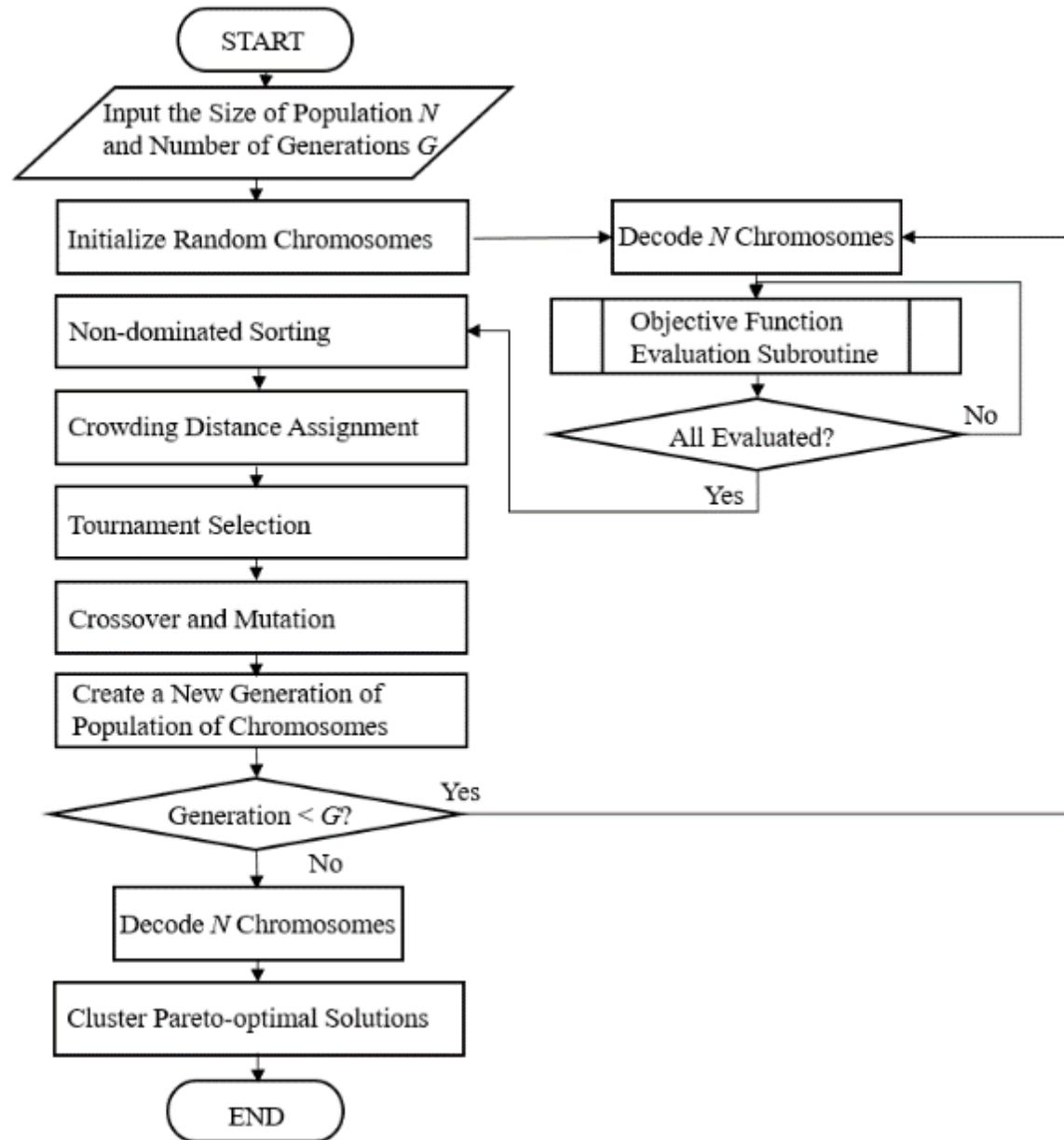

Shape Optimization

- Thermal modeling

- A slab heat conduction model is assumed for the calculation of the overall heat transfer coefficient U
- The parameters of the heat exchanger are pre-defined. E.g. the number of channels per plate, the heat exchanger core length and cold side Reynolds number, etc.

$$\frac{1}{U_h A_{s,h}} = \frac{1}{U_c A_{s,c}} = \frac{1}{h_h A_{s,h}} + \frac{t_w}{k_w A_{s,w}} + \frac{1}{h_c A_{s,c}}$$

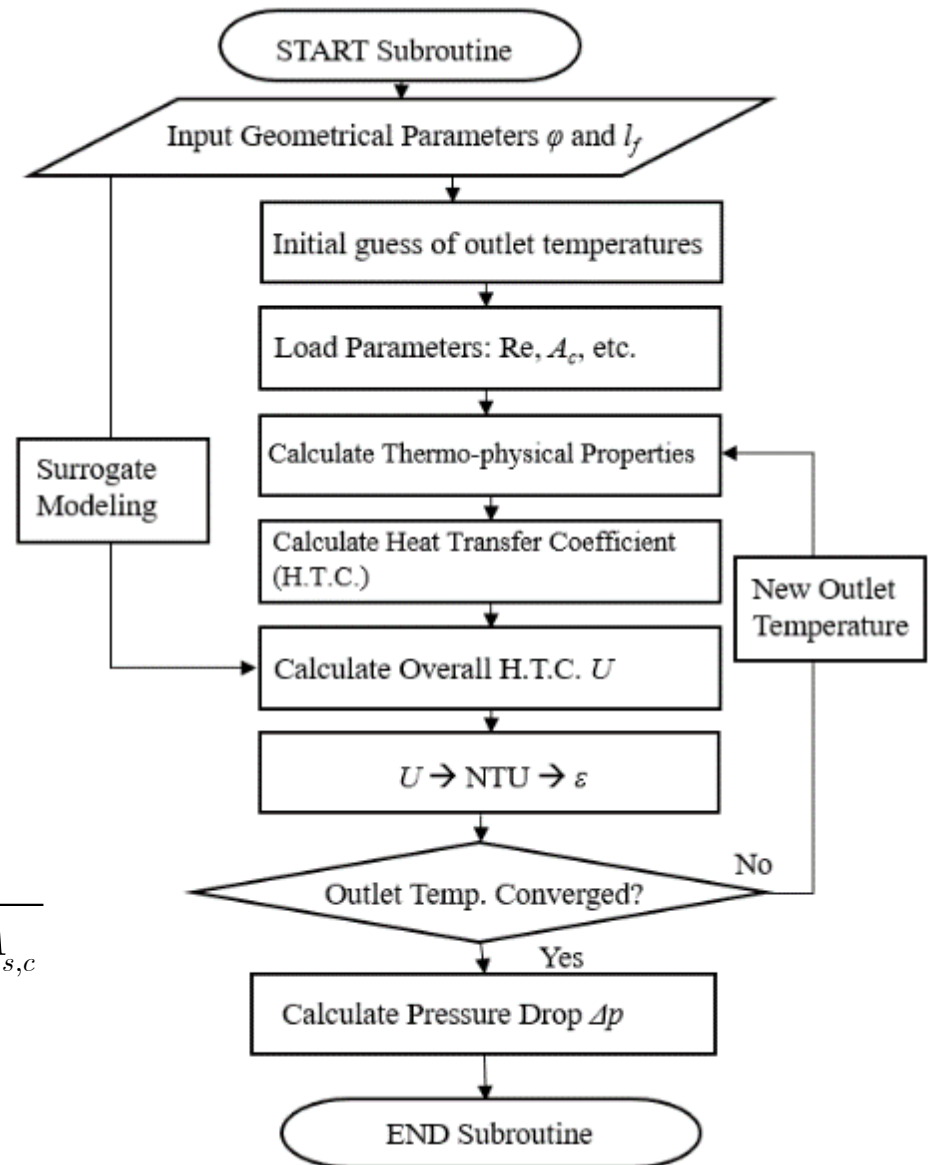

Shape Optimization—Discussion of Results

- Optimization results
 - The entire solution space with 5,000 sampled S-shaped fin designs
 - The distribution of the solutions is consistent with the expectation that the minimization of the pressure drop and the maximization of the heat transfer performance are usually conflicting with each other

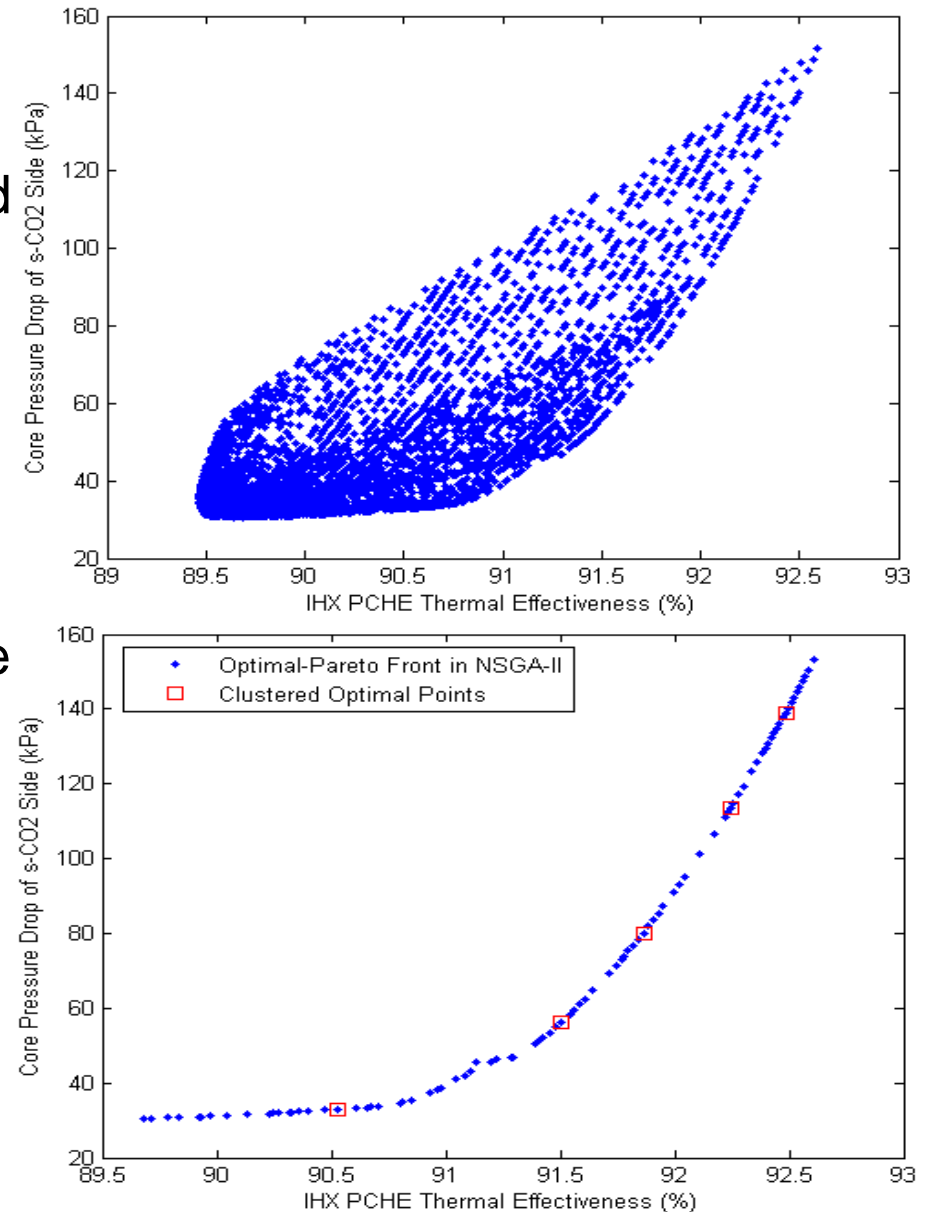

Shape Optimization—Discussion of Results

- Distribution of Pareto-optimal Solutions
 - The optimized designs can be divided into two groups: the low-angle-fin group and the high-angle-fin group
 - In the low-angle-fin group, both the small-angle and long S-shaped fins are able to reduce the pressure drop; However, the thermal effectiveness is decreased for long fins

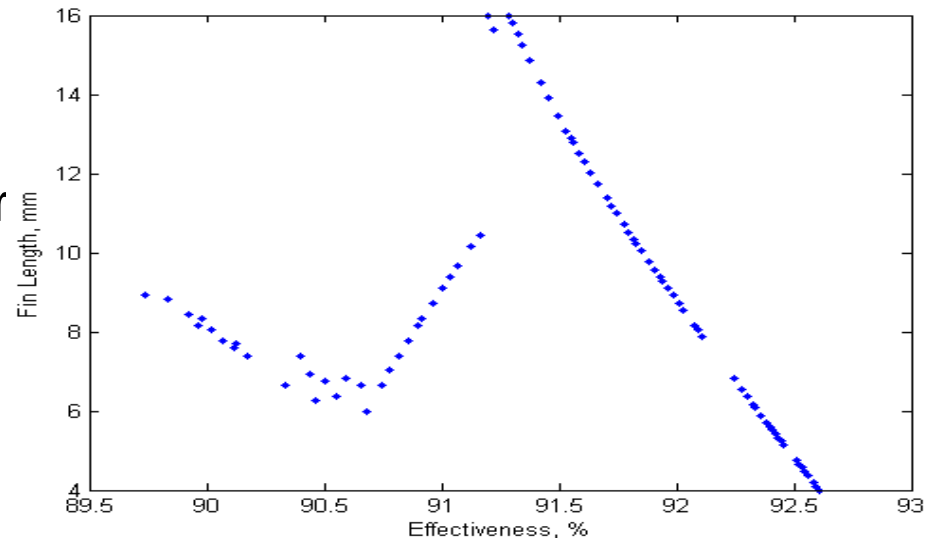
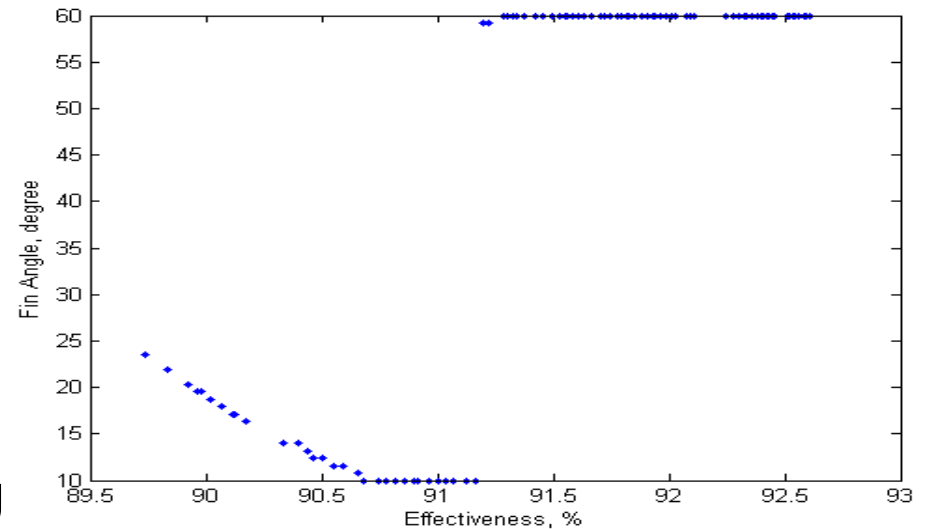

Shape Optimization—Discussion of Results

- Distribution of Pareto-optimal Solutions
 - For S-shaped fins with a fin angle of 10° , a long fin body creates a long fin tip that separates the flow along the fin body, which increases the pressure drop and enhance the heat transfer simultaneously.
 - In the high-angle-fin group, most of the fins are 60° . Short fins are favorable in terms of the thermal effectiveness. However, the pressure drop increases as the fin length decreases

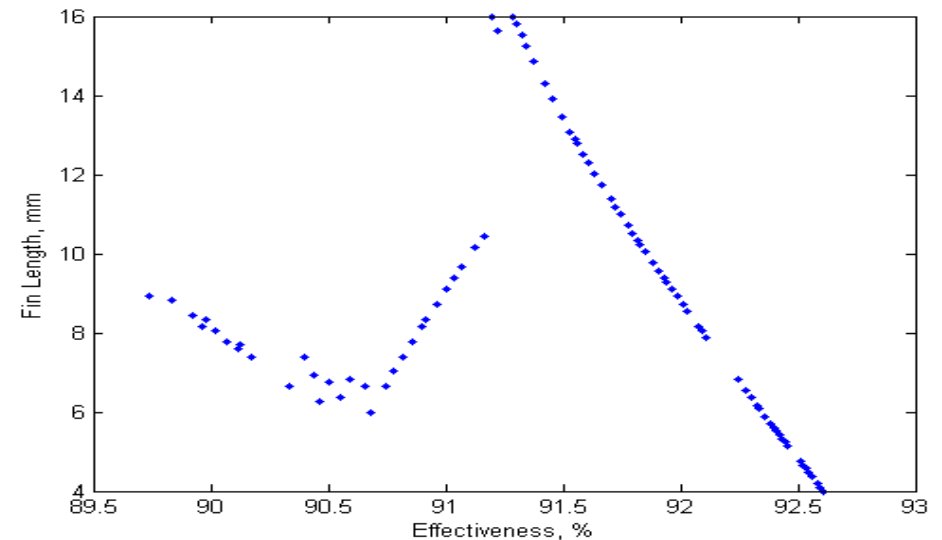
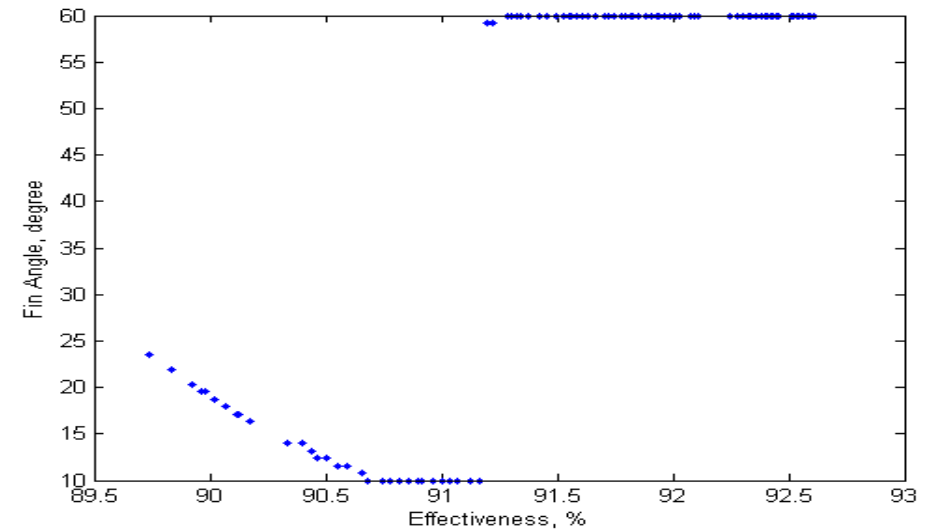

Shape Optimization—Discussion of Results

Item	Symbol	Units	#1	#2	#3	#4	#5
Fin angle	φ	degree	11.6	60.0	60.0	60.0	60.0
Fin length	l_f	mm	6.08	13.35	9.95	6.83	4.94
HX capacity	Q	kW	13.46	13.60	13.66	13.71	13.75
Cold side mass flow rate	q_m	kg/s	0.067	0.084	0.085	0.087	0.089
Cold side inlet temperature	$T_{c,in}$	°C	418.8	418.8	418.8	418.8	418.8
Cold side outlet temperature	$T_{c,out}$	°C	591.6	593.5	594.2	594.9	595.3
Reynolds number	Re	n/a	20000	20000	20000	20000	20000
HX core cold side pressure drop	Δp	kPa	33.04	56.28	80.17	113.46	138.94
Cold side heat transfer coefficient	h	kW/m ² -°C	4.538	4.329	4.611	4.931	5.154
Overall heat transfer area	A_s	m ²	0.122	0.154	0.156	0.160	0.163
HX thermal effectiveness	ε	%	90.53	91.51	91.86	92.24	92.48
Number of heat transfer units	NTU	n/a	4.00	4.25	4.35	4.45	4.53



Conclusion

- A prototypic zigzag-S-shaped-fin PCHE is designed for experimental testing on the coupled facility that is capable of running experiments up to 15 MPa and 750 °C with helium and s-CO₂
- Shape optimization is carried out for the reference S-shaped fin channels using MOEA and RSM
- The optimization results indicate that the small-fin-angle channels with large fin length are able to reduce the pressure drop while the large-fin-angle channels with small fin length are favorable in increasing the heat exchanger thermal effectiveness
- In the future, more design factors need to be taken into account such as the fin arc length and Reynolds number dependence such that the optimization results can be used in broad applications

